

Taking CNC automatic lathes to its new heights

BMF-3160-CTZ

Flange type motor spindle for CNC automatic lathe

BMF-3130-CTZ

Flange type torque motor spindle for CNC automatic lathe



Case Study 1

Check out
the video
for more details.

[Brass $\phi 1 \times 3$ mm & $\phi 3 \times 13$ mm Drilling]

Machine tool: CNC automatic lathe (CITIZEN MACHINERY CO., LTD. / Cincom L20XII Lfv)

Workpiece: Brass (C3604)

Conditions: Dry (no coolant)



$\phi 1 \times 3$ mm Drilling

- Spindle: BMF-3160-CTZ
- Tool: $\phi 1$ Drill for non-ferrous metal machining (Mitsubishi Materials Corporation / DC-SSSD0100)
- Hole depth: 3 mm (no pecking)

	Tool manufacturer's proposed conditions	Nakanishi's proposed conditions
Cutting speed [m/min]	63	188
Motor speed [min ⁻¹]	20,000	60,000
Feed per revolution [mm/rev]	0.02	0.033
Feed rate [mm/min]	400	2,000

5
times

Processing efficiency increased by 5 times faster feed rate

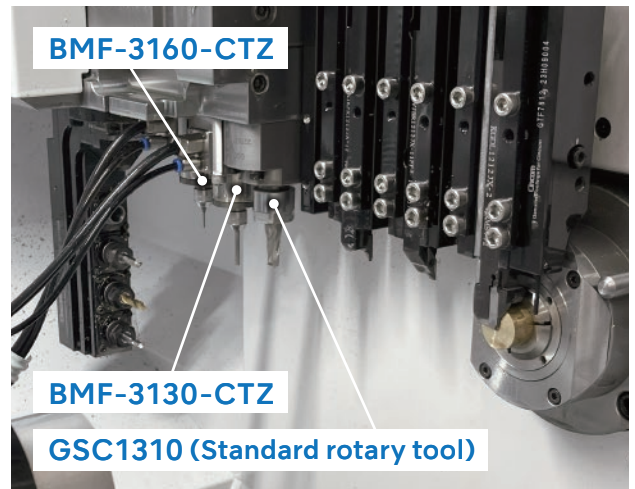

*Mounted on CITIZEN Cincom L20XII Lfv

$\phi 3 \times 13$ mm Drilling

- Spindle: BMF-3130-CTZ
- Tool: $\phi 3$ Solid carbide drill (Mitsubishi Materials Corporation / MAE0300MB)
- Hole depth: 13 mm (3 mm/step)

	Tool manufacturer's proposed conditions	Nakanishi's proposed conditions
Cutting speed [m/min]	90	283
Motor speed [min ⁻¹]	9,554	30,000
Feed per revolution [mm/rev]	0.15	0.183
Feed rate [mm/min]	1,433	5,500

3.8
times

Processing efficiency increased by 3.8 times faster feed rate

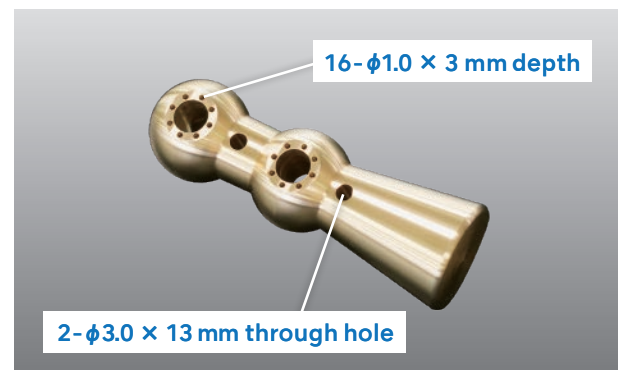

Case Study 2

Check out
the video
for more details.

[R2 Ball End Mill Brass Cutting]

CNC Automatic Lathe × 60,000 min⁻¹ Flange Type Spindle

- Spindle : BMF-3160-CTZ
- Machine : CNC automatic lathe (CITIZEN MACHINERY CO.,LTD. /Cincom L20XII Lfv)
- Tool : R2 ball end mill (NS TOOL CO.,LTD. / RSB230 R2×12)
- Workpiece material : Brass (C3604)



BMF-3160-CTZ

Nakanishi 60,000 min⁻¹ high-speed spindle

GSC1310

Standard rotary tool

*Mounted on CITIZEN Cincom L20XII Lfv

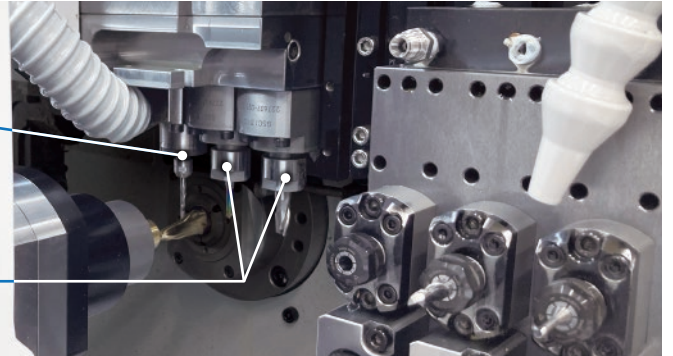

	Conventional conditions (Standard rotary tool)	Nakanishi's proposed conditions
Cutting speed [m/min]	75	754
Motor speed [min ⁻¹]	6,000	60,000
Feed rate [mm/min]	360	3,600
Feed per blade [mm/tooth]	0.03	0.03
Depth of cut (Ap × Ae) [mm]	0.03 × 0.06	0.03 × 0.06

10
times

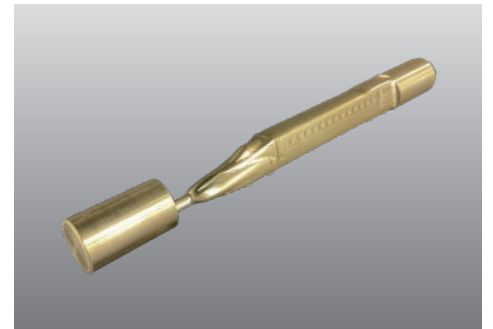

Shinkansen Model Made of Brass (C3604)

Processing efficiency increased by 10 times faster feed rate

Machining conditions

Drill : S50C (carbon steel)

Motor spindle	Tool diameter [mm]	Hole depth [mm]	Cutting speed [m/min]	Motor speed [min ⁻¹]	Feed/rev. [mm/rev]	Feed rate [mm/min]	Load meter
BMF-3160-CTZ	MISUMI Group Inc. TAC-ESDBA2.0	6 1 mm/step	126	20,000	0.010	200	Red
BMF-3130-CTZ	MISUMI Group Inc. TAC-ESDBA2.5	7.5 2.5 mm/step	126	16,000	0.020	320	Yellow 1

End mill : A5052 (aluminum alloy)

Motor spindle	Tool diameter [mm]	Cutting speed [m/min]	Motor speed [min ⁻¹]	Feed per blade [mm/tooth]	Feed rate [mm/min]	Cutting depth Ap × Ae [mm]	Load meter
BMF-3160-CTZ	Mitsubishi Materials Corporation MS2ES φ3.0	565	60,000	0.02	2,400	0.3 × 2.7	Blue 1
BMF-3130-CTZ	Mitsubishi Materials Corporation MS2ES φ3.5	330	30,000	0.05	3,000	0.35 × 3.15	Blue 1

End mill : S50C (carbon steel)

Motor spindle	Tool diameter [mm]	Cutting speed [m/min]	Motor speed [min ⁻¹]	Feed per blade [mm/tooth]	Feed rate [mm/min]	Cutting depth Ap × Ae [mm]	Load meter
BMF-3160-CTZ	Mitsubishi Materials Corporation MS2ES φ2.5	149	19,000	0.02	570	0.25 × 2.25	Blue 1
BMF-3130-CTZ	Mitsubishi Materials Corporation MS2ES φ3.0	151	16,000	0.02	640	0.3 × 2.7	Blue 1



NAKANISHI INC.

Headquarters

700 Shimohinata, Kanuma, Tochigi 322-8666, Japan
TEL: +81-289-64-3520 / FAX : +81-289-62-1135

*Specifications and design are subject to change without notice.

en.nakanishi-spindle.com
NAKANISHI INC. 2026

PR-K436E Ver.1 2026-04-02 003.NP 20

