

NR33-6000ATC-ESD

[Antistatic] Automatic Tool Change Spindle

ESD (Electro-Static Discharge) spindle is an antistatic spindle.

Prevents damage to delicate electronic components on the PCB while machining.



What is an ESD Spindle?

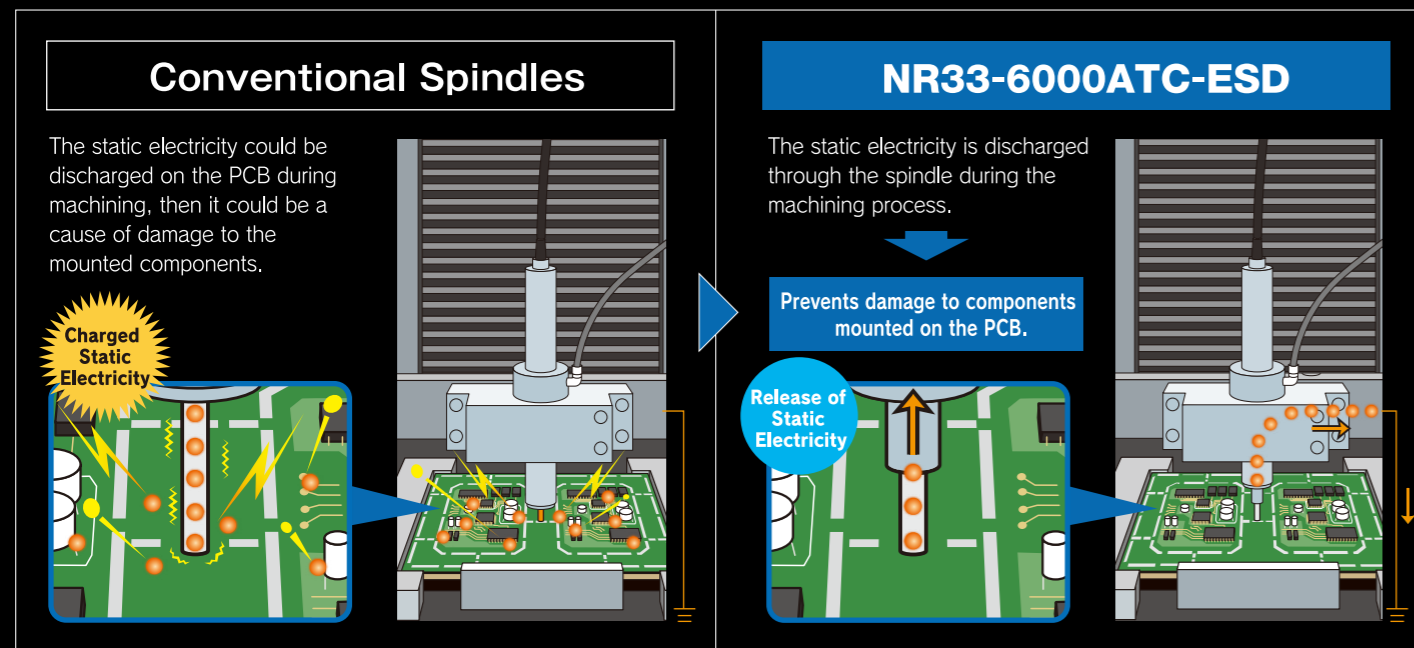

※Image is for illustrative purpose only.

Spindle Dimensions

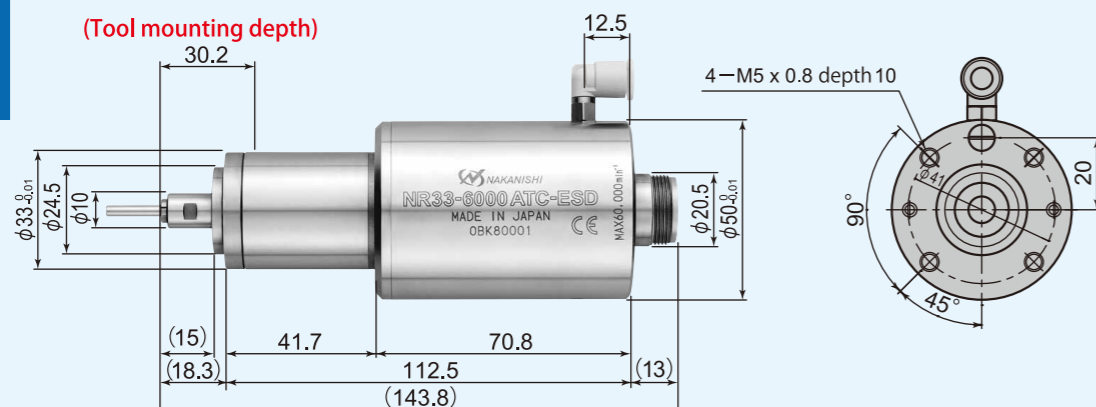

Performance Characteristics of the NR33-6000ATC-ESD

- Prevents to PCB electronic components due to static electricity conducted during the machining process.
- The 10 x 15 L extended spindle nose length helps to avoid interference with components mounted on the PCB.
- Tool clamping force is twice as strong as the NR50-5100 Series.
- Max. rotation speed is 60,000 min⁻¹.
- Automatic Tool Change feature allows for tool changing by supplying air to the spindles clamp/unclamp port.

O.D.	Allowable rotation speed	Air for collet opening	Spindle runout	Collet	Weight
∅33 mm/∅50 mm	60,000 min ⁻¹ (Motor rotation speed)	0.55 - 0.6 MPa	Within 1 μm	CHB Group (∅3.175)	1,170 g
Standard accessories	Collet ∅3.175 mm (CHB-3.175) / Spanner (6.1 x 8), (9 x 11): 1 pc. each / Bar wrench (K-236): 1 pc. Air hose with filter (K-251): ∅6 mm x 2 m				
Option	Collet (CHB group): ∅2.0, ∅3.0, ∅3.175, ∅3.5, ∅4.0 mm				

Code No. **7788** Model **NR33-6000ATC-ESD**

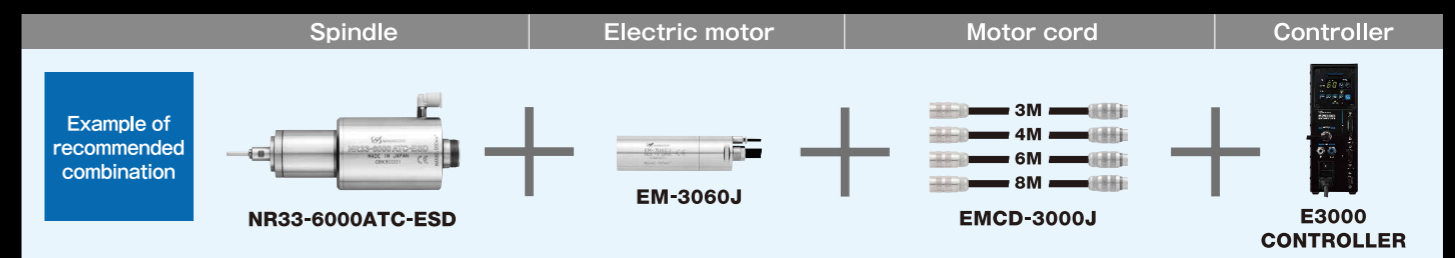

Headquarters · Factory
700 Shimohinata, Kanuma, Tochigi 322-8666, Japan
TEL +81-289-64-3520 FAX +81-289-62-1135

www.nakanishi-inc.com
NAKANISHI INC. 2020

