

# LUSTER Attachment LS-100 / ELS-100

## OPERATION MANUAL

OM-K0102E 004

Thank you for purchasing LUSTER attachment LS-100/ELS-100. These attachment are designed for lapping and honing after grinding metallic mold. The Emax EVOLution <Control Unit and Motor>, ROTUS <Air Motor> / <Air Line Kit> or Espert 500 <Control Unit and Motor> are required to drive these attachment. Read this Operation Manual carefully before use. Also read Emax EVOLution, ROTUS / Air Line Kit or Espert 500 Operation Manual.

### 1. CAUTIONS FOR HANDLING AND OPERATION

- Read these cautions carefully and only use in the manner intended.
- Warnings and cautions are intended to avoid potential hazards that could result in personal injury or damage to the device. These are classified as follows in accordance with the seriousness of the risk.

Class	Degree of Risk
<b>WARNING</b>	A safety hazard could result in bodily injury or damage to the device if the safety instructions are not properly followed.
<b>CAUTION</b>	A hazard that could result in light or moderate bodily injury or damage to the device if the safety instructions are not followed.

#### WARNING

- Do not exceed the " Maximum Allowable Motor Rotation Speed " (Refer to " 3 - 1 Specifications ").
- When sensing that the Attachment and motor are overheated during operation, reduce the working force or the motor rotation speed, or stop the operation until the Attachment cools down before restarting.

#### CAUTION ON HANDLING

- This attachment is designed for hand use. Never install this attachment or any hand tool on a machine such as a special purpose machine, NC lathe or mill.
- Use a protective cover, glasses and/or facemask for your safety during rotation.
- Do not touch bur-holder, tool etc, while they are in the reciprocating motion.
- Do not drop or hit LUSTER, because the shock could damage the internal components.
- Check if the tool/file has been mounted firmly, before operation.
- Do not force the tool/file to overload, or it may be damaged.
- Do not so overload LUSTER that could function the protective circuit.
- Be sure to keep LUSTER/motor away from water. It could cause an electric shock to the operator.
- Do not lubricate LUSTER/motor and any bearings in the system, as greasefilled bearings are used.
- After repair, initial operation, or long periods of non operational time, please use the following break-in procedure. Adjust stroke length is 1mm. Start rotating slowly and over a short period of time, then increase the speed gradually until reaching the maximum allowable speed.

#### CAUTION ON VIBRATION

##### General Warnings for All Vibrating Equipment

- Repeated or long-term exposure to excessive vibration may cause temporary or permanent physical injury, particularly to the hands, arms and shoulders.
- It is strongly recommended that anyone using vibrating equipment, such as power hand tools, first be physically examined by a doctor and then have regular medical check-ups to make sure the user doesn't have any medical problems that are being caused or worsened by using vibrating equipment. People who have impaired blood circulation to the hand, past hand injuries, nervous system disorders and Raynaud's disease should not use vibrating equipment.
- If you feel any medical or physical symptoms related to vibration (such as tingling, numbness and white or blue fingers), report the situation to your employer and seek medical advice as soon as possible.
- Avoid smoking while using vibrating equipment, as nicotine reduces the blood supply to the hands and fingers.
- Suitable gloves should be worn to reduce the vibration effects on the user.
- Tools with the lowest vibration should be used when there is a choice between different processes.
- Work schedules should be arranged to include vibration-free periods throughout each day.

##### Additional Warnings for the Safe Use of LUSTER (LS-100/ELS-100)

- LUSTER should only be used after reading and understanding the Operation Manual.
- Grip LUSTER as lightly as possible (while still keeping safe control of it).  
Let LUSTER do the work.

- To ensure your safety, LUSTER should be maintained as explained in this Operation Manual.
- Do not use LUSTER at vibration levels of 2.5 m/s<sup>2</sup> and higher. Select the combination of motor rotation speed and stroke so that the vibration level stays in the shaded area as shown on the chart lower right (Fig. 1)
- Do not use LUSTER with vibration at 2.5 m/s<sup>2</sup> or higher each day for an extended period of time.
- If any abnormal vibration occurs stop using LUSTER immediately and return to NAKANISHI for service.

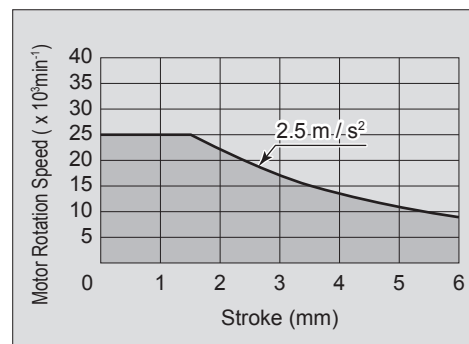

Fig. 1

### 2. FEATURES

- Tools are easy to change.
- Reciprocating speed and stroke can be easily and continuously controlled.
- You can mount various files available on the market.
- Mounted tool/file can be easily re-oriented onto the work surface.

### 3. SPECIFICATIONS AND DIMENSIONS

#### 3 - 1 Specifications

Model	LS -100	ELS -100
Applicable Control Unit	Emax EVOLution Control Unit	-
Applicable Motor	Emax EVOLution Motor (ENK-410S, ENK-250T)	ROTUS Air Motor (IM-301, IM-300)
Maximum Allowable Motor Rotation Speed	Less than 25,000min <sup>-1</sup> (rpm) (Refer to Fig. 1)	
Stroke	0 - 6 mm	
Reciprocating frequency	0 -105 cycles/second	
Weight (with Power Cord)	680g	
Vibration Level	Use the Attachment less than 2.5m / s <sup>2</sup> (Refer to Fig. 1)	
Noise Level at 1m distance	Less than 70dB (A)	

	Temperature	Humidity	Atmospheric Pressure
Operation Environment	0 - 40°C	MAX.75% (No condensation)	800 - 1,060hPa
Transportation and Storage Environment	-10 - 50°C	10 - 85%	500 - 1,060hPa

#### WARNING

- Do not exceed the " Maximum Allowable Motor Rotation Speed ".
- When sensing that the Attachment and motor are overheated during operation, reduce the working force or the motor rotation speed, or stop the operation until the Attachment cools down before restarting.

#### Standard Accessories

- Sandpaper (62552 #120, 62555 #320, 62557 #600 and 62559 #1000 ) 4 different grit size • • Each 10pcs.
- Allen Wrench (2mm, 3mm) • • Each 1pc.
- Oil • • 1pc.
- Operation Manual • • 1set.

\* Rectangle sandpapers in variety of grit sizes are available.

#### Standard Tool

	62505 Oil stone or large file can be used. The angulation can be changed.		62525 Use with holders. Use for lapping and honing as is. Use with the sandpaper provided or other polishing materials adhered on it.
	62502		
	62751 Spring in radial direction.		Lubrication Nozzle (2031)
	62527 Use with 62505, 62526, 62751.		
	62526 Use with 62525.		

#### 3 - 2 Outside View

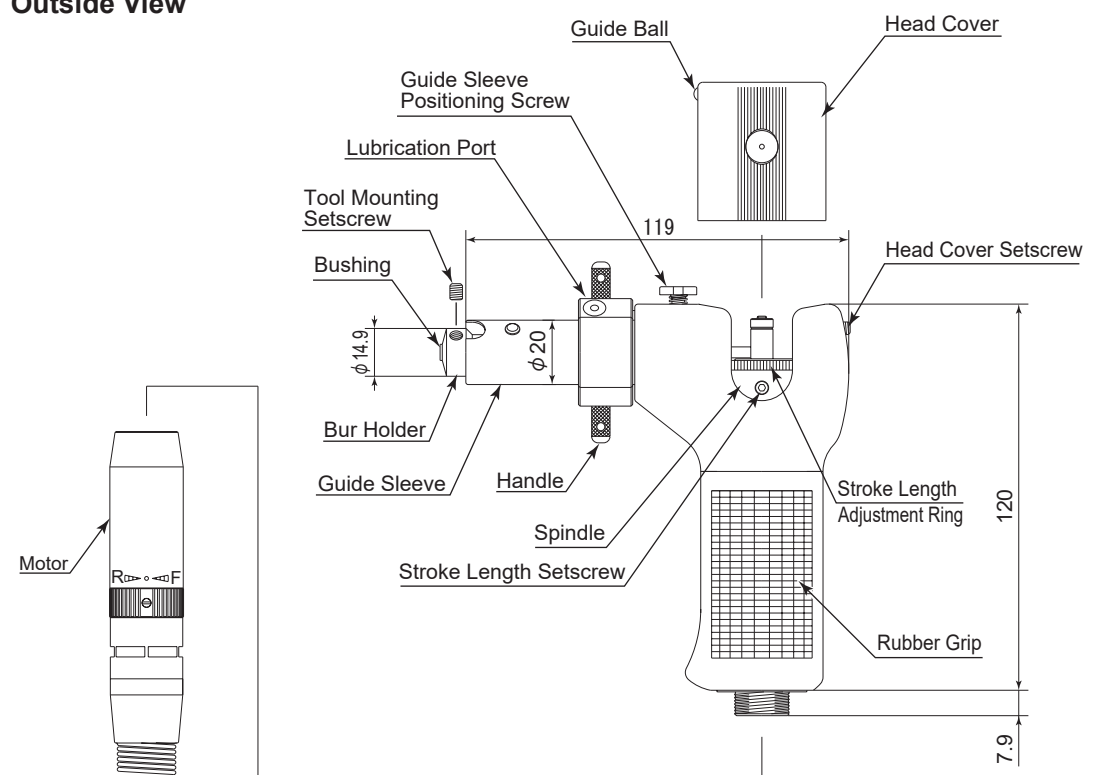

Fig. 2

### 4. CONNECTING TO THE MOTOR

#### CAUTION

Make sure your hands and all interlocking parts of the attachment and motor are clean before connecting the motor to the attachment. This is critical to prevent contaminants from entering the motor or attachment.

Insert the motor into the grip of LUSTER and turn it clockwise until it stops. Follow the procedure below to prevent damage to the Coupling Joint.

- Loosen the head cover setscrew with the allen wrench (Fig. 2).
- Slide the head cover upward to remove.
- While moving the spindle slightly right and left with a finger, insert the motor into the holding grip of the LUSTER.  
If the drive shaft of the motor does not engage the drive dog on the spindle, the spindle could not be turned. DO NOT FORCE. Turn the spindle back a few threads, rotate the cutting tool by hand to engage the drive shaft and the drive dog, and make the final turns.
- Align the guide groove on LUSTER with the guide ball on the head cover and install the head cover.
- Tighten the head cover setscrew with the allen wrench.

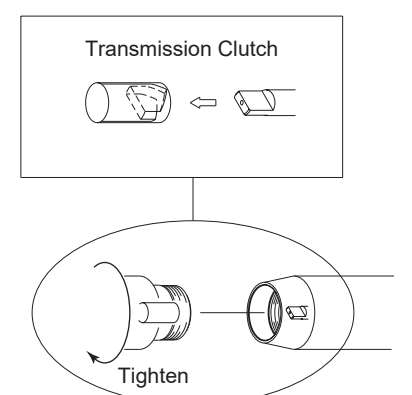

Fig. 3

## 5. CHANGING THE TOOL OR FILE

### CAUTION

Pull out plug from the power supply at all times before replacing tool, for safety reasons. Check, before operation, if tool/file is tightened firmly.

### 5 - 1 Mounting

- Insert a tool (less than  $\phi$  3.2mm) into the bur holder and tighten the tool mounting setscrew with the provided allen wrench (2mm). (Fig. 4)
- To mount larger tool  $\phi$  3.2 mm through  $\phi$  6.4mm), loosen the setscrew, remove the bushing, insert the tool and tighten the setscrew. (Fig. 5)

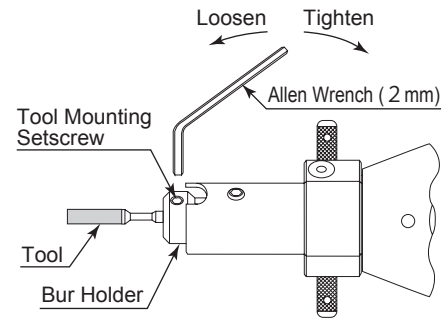

Fig. 4

### 5 - 2 Removing

Loosen the tool mounting setscrew with the supplied allen wrench (2mm), and remove. To re-install the bushing, align the guide ball on the bushing with the slot. (Fig. 5)

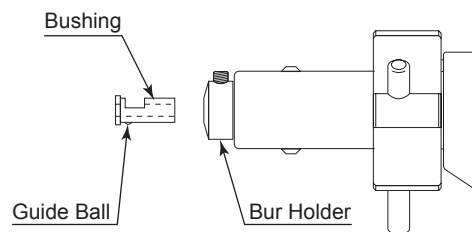

Fig. 5

## 6. ADJUSTING STROKE LENGTH

### WARNING

Do not exceed the " Maximum Allowable Motor Rotation Speed " (Refer to " 3 - 1 Specifications ").

### CAUTION

Pull out plug from the power supply when adjusting the stroke length, for safety reasons.

- Loosen the head cover setscrew with provided allen wrench (2mm) (Fig. 2).
- Slide the head cover up ward, and remove (Fig. 2).
- Loosen the stroke length setscrew with the allen wrench (2mm) (Fig.6).
- Turn the adjustment ring, while holding the spindle with your finger, and align the desired stroke length with the indicator line. The stroke length can be adjusted between 0 - 6 mm. (0 - 0.236") (Fig. 7)
- Tighten the stroke length setscrew with the allen wrench (2mm). (Fig. 6)
- Insert the head cover and push it down, aligning the guide groove on attachment and the guide ball on the head cover (Fig. 2).
- Fasten the head cover setscrew with the allen wrench (2mm) (Fig.2).
- Adjust the stroke according to the " 1. CAUTIONS FOR HANDLING AND OPERATION (Fig. 1) ".

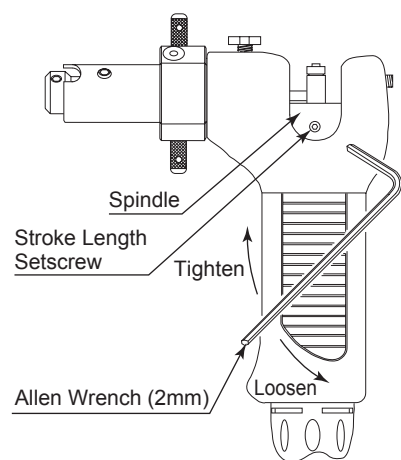

Fig. 6

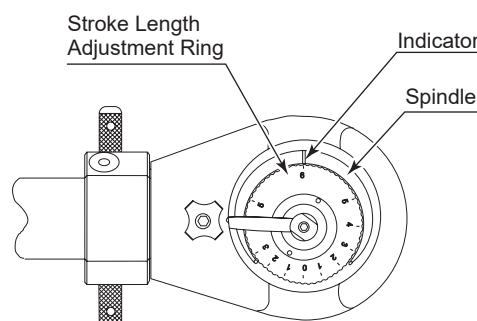

Fig. 7

## 7. ORIENTATION OF GUIDE SLEEVE / TOOL

Mounted tool can be re-oriented.

- Loosen the guide sleeve positioning screw to make the guide sleeve smoothly rotate (Fig.8). This can allow the tool to fit the work surface with ease.
- Fasten the guide sleeve positioning screw to fix tool (Fig.8). This completes re-orientation of the tool.

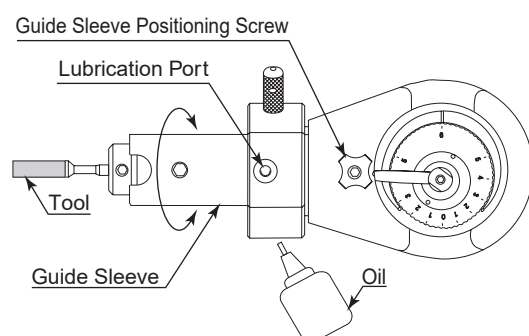

Fig. 8

## 8. LUBRICATION

Lubricate the attachment at least once a day from the lubrication port as shown (Fig. 8). In case the supplied oil depletes and NAKANISHI Oil cannot be found, use the turbine oil class 1 ISO VG32.

## 9. APPLICATIONS

- Finishing the complicated shapes and sizes (Fig. 9).  
(For press dies, Drawing dies, etc.)
  - Machine by 0.05 mm.
  - File finish the clearance by 0.02 mm Max.
  - Heat treat the work.
  - Hone or lap the edges.
  - Final polish by lapping or honing grindstone.
  - Polish the surface of dies.

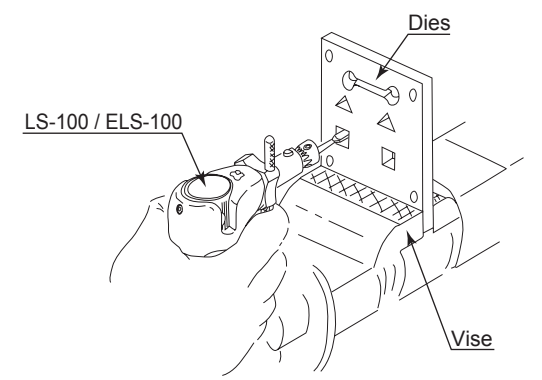

Fig. 9

- Finishing of grooves (Fig. 10)  
With use of proper tools that are supplied with, finish the surface by filing, lapping or honing, and final polish.

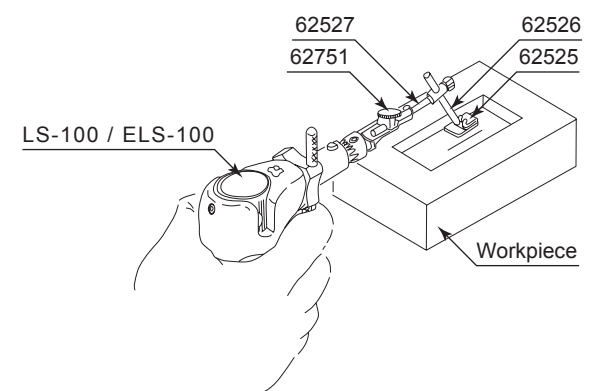

Fig. 10

## 10. TYPICAL USE OF ACCESSORIES

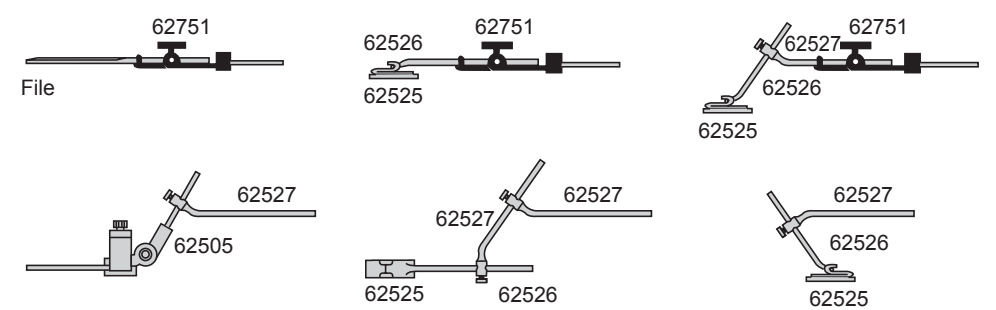

Fig. 11

## 11. TROUBLESHOOTING

If a problem or concern occurs, please check the following prior to consulting your dealer.

Trouble	Cause	Inspection
Reciprocating stroke is poor.	Low lubricant.	Lubricate oil properly.
Guide Sleeve slippage.	Guide Sleeve Screw improperly.	If the guide sleeve is slips after retightening, return to NAKANISHI dealer service
Heat generation during rotation.	Ball bearing worn out by the reason ground particles stock in the air of ball bearing.	Replace the ball bearings. (Return to NAKANISHI dealer service.)
Abnormal noise or unusual vibration during rotation.	Ball bearings worn due to debris particles in the ball bearings. The ball bearings are worn.	
Tool will not tighten.	The tool mounting setscrew has loosened.	Check if the tool mounting setscrew is properly positioned. Clean it and retighten.

## 12. DISPOSAL OF THE ATTACHMENT

When disposal of a Attachment is necessary, follow the instructions from your local government agency for proper disposal of industrial components.