

Air Motor

AM - 3020

OPERATION MANUAL

Thank you for purchasing the Air Motor "AM - 3020". The spindle and reducer, lubricator / regulator, Air Line Kit are required to drive this Air Motor. Read this and all the associated component Operation Manuals carefully before use. Always keep this Operation Manual in a place where a user can refer to for reference at any time.

1. CAUTIONS FOR HANDLING AND OPERATION

- Read these warnings and cautions carefully and only use in the manner intended.
- These warnings and cautions are intended to avoid potential hazards that could result in personal injury to the operator or damage to the device. These are classified as follows in accordance with the seriousness of the risk.

Class	Degree of Risk
WARNING	A safety hazard could result in bodily injury or damage to the device if the safety instructions are not properly followed.
CAUTION	A hazard that could result in light or moderate bodily injury or damage to the device if the safety instructions are not followed.

WARNING

- This Air Motor is not a hand tool. It is designed to be used on CNC machines or special purpose machines.
- Do not touch the cutting tool while it is running. It is very dangerous.
- Wear safety glasses, dust mask, and use a protective cover around the Air Motor whenever the Air Motor is rotating.
- Never operate or handle the Air Motor and spindle until you have thoroughly read the Operation Manuals and safe operation has been confirmed.
 - To prevent injuries / damages, check the Air Motor, spindle and cutting tool for proper installation, before operating the Air Motor and spindle.
 - Before disconnecting the Air Motor and spindle, always turn the control power off and turn off the compressed air supply to the Air Line Kit. Then it is safe to remove the Air Motor and spindle.

CAUTION

- Do not drop or hit this Air Motor, as shock can damage to the internal components.
- This Air Motor uses an oil mist. If oil is not supplied to the Air Motor, damage to the internal components of the Air Motor will occur.
- Before use, carefully read "Air Line Kit Operation Manual" regarding the correct connection, operation and cautions when using the Air Line Kit.
- When cleaning an Air Motor, stop the Air Motor and remove debris with a soft brush or a cloth. Do not blow air into the Air Motor with compressed air as foreign particles or cutting debris may get into the ball bearing.
- Operating the Air Motor in low Lubricant conditions will cause low rotation speed, damage to the internal components and shorter life of the Air Motor.
- Be sure to drain moisture and condensation from the Air Line Kit (air filter bowl) regularly to avoid moisture being carried to the Air Motor. This may cause damage to the Air Motor.
- Select suitable products or tools for all applications. Do not exceed the capabilities of the Air Motor or tools.
- Do not stop the Air Motor while coolant spray is being applied to the cutting tool. Removing the air pressure from the Air Motor causes a loss of purging, allowing the Air Motor to ingest coolant. This will cause damage to the Air Motor.
- Carefully direct coolant spray to the tool. Do not spray directly on the Air Motor body. If large amount spray directly on the Air Motor, it may cause excess load of the Air Motor rotation with loss of durability to the Air Motor.
- Stop working immediately when abnormal rotation or unusual vibration are observed. Immediately, please check the content of section "9. TROUBLESHOOTING".
- Always check if the connection hose and supply and exhaust air / oil hose for damaged before and after operating.
- After installation, repair, initial operation, or long periods of non operation, please carry out break-in as follow. Start rotating slowly and over a short period of 15 - 20 minutes, increase speed gradually until allowable maximum speed.
- Do not disassemble, modify or attempt to repair this Air Motor. Additional damage will occur to the internal components. Service must be performed by NSK NAKANISHI or an authorized service center.
- When using this Air Motor for mass production, please consider the purchase of an additional Air Motor to be used as a back-up in case of emergency.
- Securely connect the compressor supply connection hose to the Air Line Kit, and, connect the supply and exhaust air / oil hose to the Air Line Kit and the Air Motor to avoid accidental disconnection during use.

2. BASIC PACKAGE

When opening the package, check if it includes all items listed in "Table. 1 Packing List Contents". In the event of any shortage, please contact either NAKANISHI (see the "4. CONTACT US" section) or your local dealer.

Table. 1 Packing List Contents

Air Motor • • 1pc.	Wrench (22 x 27) • • 1pc.
Supply Air / Oil Hose (with Filter Joint (FJ - 01)) • • 1pc.	Exhaust Air / Oil Hose (with Silencer (K- 208)) • • 1pc.
Operation Manual • • 1set	Inspection Card • • 1pc.

3. WARRANTY

We provide a limited warranty for our products. We will repair or replace the products if the cause of failure is due to the following manufactures defects. Please contact us or your local distributor for details.

- Defect in manufacturing.
- Any shortage of components in the package.
- Where damaged components are found when initially opening the package. (This shall not apply if the damage was caused by the negligence of a customer)

4. CONTACT US

For your safety and convenience when purchasing our products, we welcome your questions. If you have any questions about operation, maintenance and repair of the product, please contact us.

Contact Us

- For U.S. Market
 - Company Name : **NSK America Corp.**
Industrial Div.
 - Business Hours : 8:00 to 17:00 (CST)
(closed Saturday, Sunday and Public Holidays)
 - U.S. Toll Free No. : +1 800 585 4675
 - Telephone No. : +1 847 843 7664
 - Fax No. : +1 847 843 7622
 - Website : www.nskamericacorp.com
- For Other Markets
 - Company Name : **NAKANISHI INC.**
 - Business Hours : 8:00 to 17:00 (JST)
(closed Saturday, Sunday and Public Holidays)
 - Telephone No. : +81 289 64 3520
 - e-mail : webmaster-ie@nsk-nakanishi.co.jp

5. FEATURES

- The Air Motor housing is made from precision ground, hardened, stainless steel (SUS) with an outside diameter of $\phi 30\text{mm}$.
- No heat is generated for long continuous use due to air driven operation.
- By mounting a silencer on the back exhaust air / oil hose, the quiet operation of air turbine is remarkably improved.
- Air consumption is 178 N ℓ / min and can be used with air compressor of 3HP (2.2 kw).

6. SPECIFICATIONS AND DIMENSIONS

6 - 1 Specifications

Model	AM - 3020R	AM - 3020L	AM - 3020RA	AM - 3020LA
Maximum Motor Rotation Speed	19,000min ⁻¹ (rpm) (at 0.5MPa (72.5psi) Air Pressure)		18,000min ⁻¹ (rpm) (at 0.5MPa (72.5psi) Air Pressure)	
Appropriate Air Pressure	0.3 - 0.5MPa (43.5 - 72.5psi)			
Air Consumption	180N ℓ / min		175N ℓ / min	
Max. Output	130W		125W	
Weight	298g		339g	
Noise Level at 1m distance	Less than 75dB (A)			
Supply and Exhaust Air / Oil Hose Dimensions	Supply : ID $\phi 4.0\text{mm}$ x OD $\phi 6.0\text{mm}$ Length : 2m Exhaust : ID $\phi 6.0\text{mm}$ x OD $\phi 8.0\text{mm}$ Length : 1m			

	Temperature	Humidity	Atmospheric Pressure
Operation Environment	0 - 40°C	MAX.75% (No condensation)	700 - 1,060hPa
Transportation and Storage Environment	-10 - + 50°C	10 - 85%	500 - 1,060hPa

CAUTION

The standard length of supply air / oil hose is 2m, and exhaust air / oil hose is 1m. When the supply and exhaust air / oil hose is longer than the standard length, the rotating speed is decreased.

6 - 2 Outside View

① AM - 3020R / AM - 3020L

② AM - 3020RA / AM - 3020LA

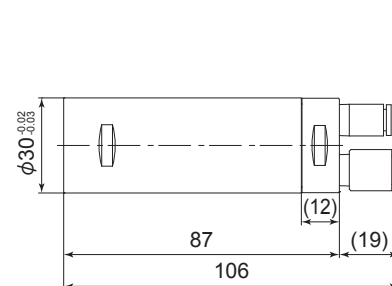

Fig. 1

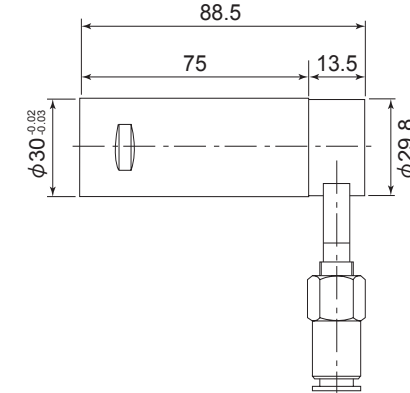

Fig. 2

7. CONNECTION OF THE AIR MOTOR TO THE SPINDLE

CAUTION

Make sure your hands and all interlocking parts of the spindle and Air Motor are clean before connecting the Air Motor to the spindle. This is critical in preventing contaminants from entering the Air Motor or spindle.

Align the thread on the front end of the Air Motor and the rear of the spindle, and turn the spindle clockwise. If the drive shaft of the Air Motor does not engage properly to the drive dog on the spindle, it may only turn approximately two threads before stopping. DO NOT FORCE THEM TOGETHER. Loosen the spindle from the Air Motor, rotate the spindle shaft by hand then re-try. The drive shaft and the drive dog must be fully engaged. When fully engaged, secure the Air Motor and spindle using the provided 27mm wrench.

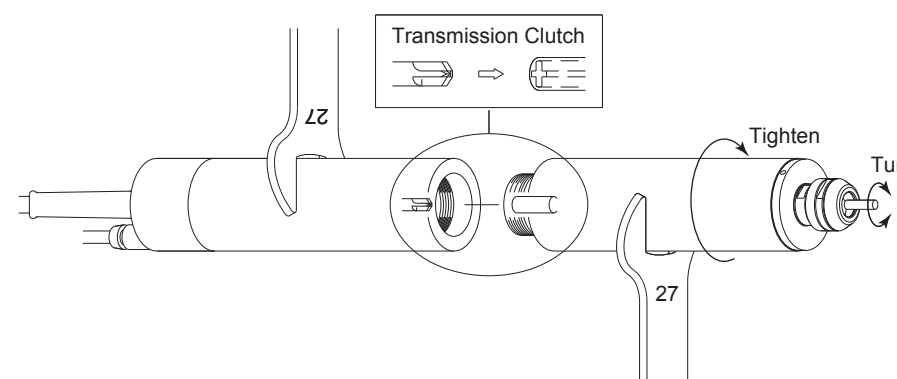

Fig. 3

8. CONNECTION TO THE AIR LINE KIT

CAUTION

Make sure to turn the compressed air supply to the Air Line Kit OFF, before replacing the Lubricating Oil or draining the water in Lubricating Oil.

- Connect the Filter Joint of the supply air / oil hose to the Secondary Joint ($\phi 6$ One - Touch Joint) of the Air Line Kit (Fig. 4 ①).
- Fill Oil Reservoir through the Oil Filler Cap with recommended NAKANISHI Lubricating Oil (K - 211 : Air Line Kit's Standard Accessories) to Upper Limit. Disconnect from air supply prior to opening Oil Filler Cap. Do not over or under fill.
- Connect the connection hose (Air Line Kit's Standard Accessories) to the Primary Joint of the Air Line Kit and Compressor (Fig. 4 ②).
- Supply air from the air compressor and turn the Regulator Knob to set air pressure between 0.3 - 0.5MPa (43.5 - 72.5psi).

- Turn the ON / OFF Valve and rotate the Air Motor with recommended proper air pressure. Adjust the Oil Drip Rate to the recommended volume which is 1 to 3 drops / min. (Commercially Air Line Kit is same Oil Drip Rate). (If using the "AL - 0304 " or " K - 239 " Air Line Kit, adjust the proper Oil Drip Rate to 30 - 40 drops / min). * Refer to the Operation Manual of the Air Line Kit for detailed information.
- Be sure to adjusted to proper Oil Drip Rate before using the Air Motor.

Lubricating Oil

Use ISO VG15 Liquid Paraffin (Shell Ondina Oil #15) in the Air Line Kit lubricator bowl. (For U.S.A. specification, use Chevron Superla #9).

Model
• Lubricating Oil (K - 211) 70cc
• Lubricating Oil (K - 202) 1 ℓ

CAUTIONS IN USING AIR LINE KIT

- When connecting the Compressor and Air Line Kit, recommended install the air filter or air dryer to between Compressor and Air Line Kit in order to supply clean dry air to the Air Motor. Using compressed air containing excessive moisture could result in malfunction or failure of the Air Motor. If excessive moisture or condensation are found in Air Filter Bowl (Filter Regulator Bowl), it will be necessary to install a dryer and larger air filter on the Primary Joint side of the Air Line Kit to prevent and remove excessive moisture.
- Connect the input air supply connection hose and supply air / oil hose securely to avoid accidental disconnection during use. Input air pressure should never exceed 1.0MPa (145psi). Air pressure exceeding 1.0MPa (145psi) may cause the supply connection hose and or air / oil hose supply to rupture.
- Make sure operation air pressure is less than 1.0MPa (145psi) before connecting the input supply connection hose and air / oil supply hose. If operation air pressure is exceeds 1.0MPa (145psi), injury to the operator may occur by accidental disconnection before or during use.
- Before use, carefully read "Air Line Kit Operation Manuals" regarding the correct connection, operation and cautions when using the Air Line Kit.

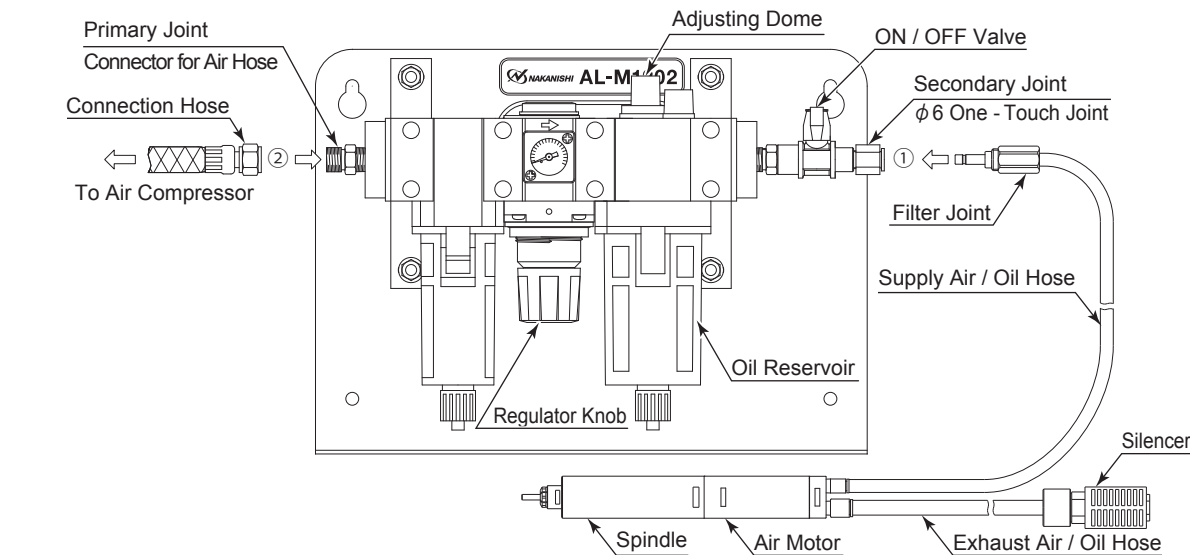

Fig. 4 Connection of Air Line Kit "AL - M1202 (Sold Separately) "

9. TROUBLESHOOTING

If a problem or concern occur, please check the following items prior to consulting your dealer.

Trouble	Cause	Inspection / Corrective Action
Air Motor does not rotate or rotate smoothly.	Air flow does not reach the Air Motor.	Check if input supply connection hose or air / oil supply hose is broken, bent or disconnected. Check connection of the input supply connection and air / oil supply hoses. Check the compressor power supply and the air compressor output. Check the Regulator and set to the correct air pressure. Check all connections input supply and air / oil supply hose.
Motor speed decrease.	The spindles ball bearings have been damaged.	Replace the ball bearings. (Return to NAKANISHI dealer service.)
	The motor has been damaged by for no Lubricating Oil.	Replace the motor. (Return to NAKANISHI dealer service.)
The connection hose or air / oil supply hose have been damaged.	Poor connection of input supply or air / oil supply hose.	Replace the input supply and or air / oil supply hoses.
	Low air pressure.	Check all threaded joints and re-tighten if necessary. Check the Compressor, Air Circuit, and Regulator.
Low Lubricating Oil.	Low Lubricating Oil.	Check lubricator for proper lubricant level. Set the Oil Drip Rate from 1 to 3 drops / min. * If using the "AL - 0304 or K - 239 " Air Line Kit, adjust the proper Oil Drip Rate to 30 - 40 drops / min.
	No Lubricating Oil.	Clean inside of the motor use the Lubricating Oil. Removing the Filter Joint from Air Line Kit, supply a small amount of Lubricating Oil directly into the Filter Joint. Afterwards, supply air pressure and rotate the Air Motor. Flush dirt in the motor and repeatedly do this work about three times. When the improvement is not seen, return to NAKANISHI dealer service.
Water, dirt and debris are collected in the Air Filter.	Water in Lubricating Oil reservoir.	Drain water, dirt and debris from the Air Filter Bowl. Drain water from Lubricating Oil reservoir and replace with clean Lubricating Oil.
	Unequal motor rotation.	Lubricator inclined or upside down. Inclined or upside down lubricator will flood spindle with lubricating Oil.
Excessive Oil Drip Rate flooding the bearings.	Over filled lubricator. (Air Line Kit "AL - 0304 or K - 239 " only.)	Oil drip rate exceeds the recommended amount. Adjust for the proper Oil Drip Rate. Drain the Lubricating Oil from Reservoir to meet indicated levels. Excess lubricant will flood spindle. → Draining the lubricating oil until upper limit below by opening the Drain Valve.
	Overheating during rotation.	Cutting debris has contaminated the ball bearings, and the ball bearings are damaged.

10. DISPOSAL OF THE AIR MOTOR

When disposal of an Air Motor is necessary, follow the instructions from your local government agency for proper disposal of industrial components.