

90° Angle Spindle

RA - 151E



OPERATION MANUAL

OM-K0422E 002

Thank you for purchasing 90° Angle Spindle " RA - 151E ". This Spindle is designed for grinding, small diameter drilling and milling, etc. The E3000 CONTROLLER, Brushless Motor or Air Motor and Air Line Kit are required to drive this Spindle. Read this and all the associated component Operation Manuals carefully before use. Always keep this Operation Manual in a place where a user can refer to for reference at any time.

1. CAUTIONS FOR HANDLING AND OPERATION

- Read these warnings and cautions carefully and only use in the manner intended.
- These warnings and cautions are intended to avoid potential hazards that could result in personal injury to the operator or damage to the device. These are classified as follows in accordance with the seriousness of the risk.

Class	Degree of Risk
 WARNING	A safety hazard could result in bodily injury or damage to the device if the safety instructions are not properly followed.
 CAUTION	A hazard that could result in light or moderate bodily injury or damage to the device if the safety instructions are not followed.

WARNING

- ① This Spindle is not a hand tool. It is designed to be used on CNC machines or special purpose machines.
- ② Do not touch the cutting tool while it is running. It is very dangerous.
- ③ Wear safety glasses, dust mask, and use a protective cover around the Spindle whenever the Spindle is rotating.
- ④ Never connect, disconnect or touch the Power Cord Plug or Motor Cord Plug with wet hands. This may cause an electric shock.
- ⑤ Never operate or handle the motor and Spindle until you have thoroughly read the Operation Manuals and safe operation has been confirmed.
 - 1) To prevent injuries / damages, check the motor, Spindle and cutting tool for proper installation, before operating the motor and Spindle.
 - 2) Before disconnecting the motor and Spindle, always turn the control power off and turn the compressed air supply to the CONTROLLER off. Then it is safe to remove the motor and Spindle.
- ⑥ When installing a Spindle to a fixed base, make sure the fixed base is grounded in order to avoid the risk of an electric shock.
- ⑦ When installing a tool, tighten the collet chuck correctly and check again the collet chuck before use. Do not over-tighten the collet chuck. This may cause damage to the Spindle.
- ⑧ Do not use bent, broken, chipped, out of round or sub-standard tools, as this may cause them to shatter or explode. Tools with fractures or a bent shank will cause injury to the operator. When using a new tool, rotate it in a low speed and increase speed gradually for safety.
- ⑨ Do not exceed the maximum recommended allowable tool speed. For your safety, use speeds below the maximum allowable speed.
- ⑩ Do not apply excessive force. This may cause tool slippage, tool damage, injury to the operator or loss of concentricity and precision.

CAUTION

- ① Do not exceed the maximum allowable motor speed of 20,000min⁻¹ (rpm).
- ② Do not drop or hit this spindle, as shock can damage to the internal components.
- ③ Be sure to clean the collet chuck, the inside of the Spindle before replacing the tool. If ground particles or metal chips stick to the inside of Spindle or the collet chuck, damage to the collet chuck or Spindle can occur due to the loss of precision.
- ④ When cleaning a Spindle, stop the motor and remove debris with a soft brush or a cloth. Do not blow air into the Spindle with compressed air as foreign particles or cutting debris may get into the ball bearing.
- ⑤ Always clean the tool shank before installing the tool in the Spindle.
- ⑥ When sizing the correct collet chuck size to the tool shank diameter, a tolerance of + 0 ~ - 0.01mm is strongly recommended. A tool shank within the + 0 ~ - 0.1mm range is mountable, however, this may cause poor concentricity and or insufficient tool shank gripping force.
- ⑦ Select suitable products or tools for all applications. Do not exceed the capabilities of the Spindle or tools.
- ⑧ During supply of coolant spray, do not stop the supply air pressure.
If stop the supply air pressure, entering coolant spray to internal Air Turbine Spindle by lost air purge. This may occur damage to the Air Turbine Spindle.
- ⑨ Carefully direct coolant spray to the tool. Do not spray directly on the Spindle body.
- ⑩ Stop working immediately when abnormal rotation or unusual vibration are observed. Immediately, please check the content of section " 10. TROUBLESHOOTING ".
- ⑪ Always check if the tool, collet chuck are damaged before and after operating.
- ⑫ If the collet chuck show signs of wear or damage, replace it before a malfunction or additional damage occurs.
- ⑬ After installation, repair, initial operation, or long periods of non operation, please refer to section " 8. BREAK-IN PROCEDURE " detailed in Table 1. When checking the Spindle, no vibration or unusual sound should be observed during rotation.
- ⑭ Do not disassemble, modify or attempt to repair this Spindle. Additional damage will occur to the internal components. Service must be performed by NSK NAKANISHI or an authorized service center.
- ⑮ When using this Spindle for mass production, please consider the purchase of an additional Spindle to be used as a back-up in case of emergency.

2. FEATURES

- ① The RA - 151E is capable of working on corners difficult to work or unfit for working with straight type Spindle.
- ② The Spindle housing is made from precision ground, hardened, stainless steel (SUS) with an outside diameter of ϕ 30mm.
- ③ Various sizes of collet chucks are available CH8 0.8mm - 3.0mm. Standard collet chuck is CH8 3.0mm or CH8 3.175mm. (For U.S. market CH8 3.175mm.)

3. SPECIFICATIONS AND DIMENSIONS

3 - 1 Specifications

Model	RA - 151E	
Maximum rotating speed at the tool	For Air Motor	7,200min ⁻¹ (rpm)
	For Brushless Motor	7,490min ⁻¹ (rpm)
Maximum Motor Rotation Speed	For Air Motor	19,000min ⁻¹ (rpm)
	For Brushless Motor	20,000min ⁻¹ (rpm)
Applicable Motor	For Air Motor	AM - 3020R / L, AM - 3020RA / LA
	For Brushless Motor	EM - 3060, EM - 3060J, EM - 3060J - 2M, EM - 3030J, EM - 3030J - 2M
Reduction Ratio	1 / 2.67	
Standard Collet Chuck (CH8 - 3.0)	ϕ 3.0mm	
Weight	385g	

⚠ CAUTION

Use less than the maximum allowable motor speed $20,000\text{min}^{-1}$ (rpm).
DO NOT exceed the maximum allowable motor speed $20,000\text{min}^{-1}$ (rpm) for the Spindle.

Standard Accessories

- Collet Chuck $\phi 3.0\text{mm}$ (CH8 - 3.0) or $\phi 3.175\text{mm}$ (CH8 - 3.175) · · · 1pc.
(For U.S. market $\phi 3.175\text{mm}$ (CH8 - 3.175))
- Wrench (7 × 5.5) · · · 1pc.
- Wrench (8 × 5) · · · 1pc.
- Wrench (22 × 27) · · · 1pc.
- Operation Manual · · · 1set.

< Option >

* The collet chuck is attached to the Spindle.

Collet Chuck (CH8 - □□) $\phi 0.8\text{mm} \sim \phi 3.0\text{mm}$ in 0.1mm increments and $\phi 2.35\text{mm}$, $\phi 3.175\text{mm}$

3 - 2 Outside View

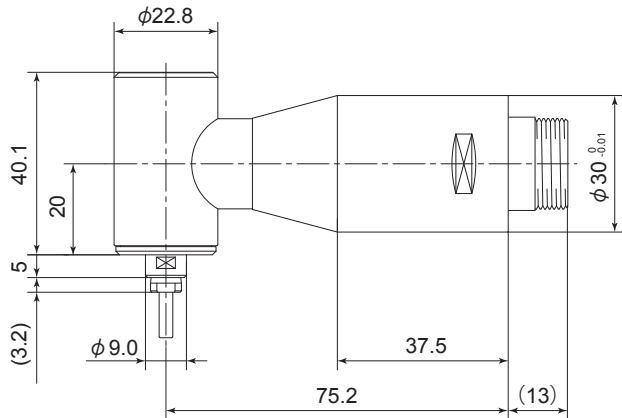

Fig. 1

4. CONNECTION OF THE SPINDLE TO THE MOTOR

⚠ CAUTION

Make sure your hands and all interlocking parts of the Spindle and motor are clean before connecting the motor to the Spindle. This is critical in preventing contaminants from entering the motor or Spindle.

Align the thread on the front end of the motor and the rear of the Spindle, and turn the Spindle clockwise. If the drive shaft of the motor does not engage properly to the drive dog on the Spindle, it may only turn approximately two threads before stopping. DO NOT FORCE THEM TOGETHER. Loosen the Spindle from the motor, rotate the Spindle shaft by hand then re-try. The drive shaft and the drive dog must be fully engaged. When fully engaged, secure the motor and Spindle using the provided 27mm wrench (Fig. 2).

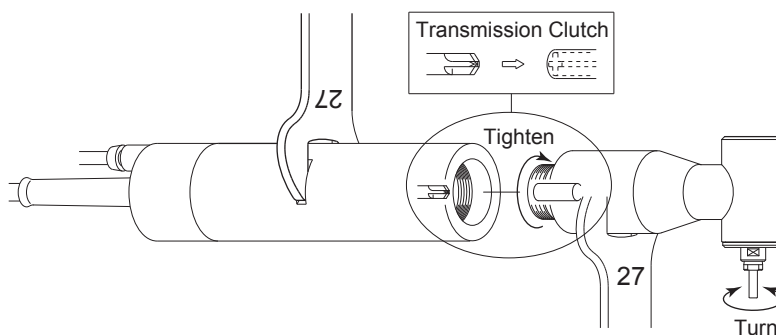

Fig. 2

5. CHANGING THE TOOL

⚠ CAUTION

Do not tighten the collet chuck without inserting a tool or dummy bur as this will result in damage to the collet chuck.

RECOMMENDATION

Please minimize the tool overhang amount to maintaining high accuracy.

- ① Set the provided 8mm wrench on the Spindle.
- ② Place the provided 5.5mm wrench on the chuck and turn it counter-clockwise to loosen the collet chuck and remove the tool.
- ③ Clean the collet chuck, then insert the new tool and tighten the collet chuck by turning clockwise. Do not overtighten.

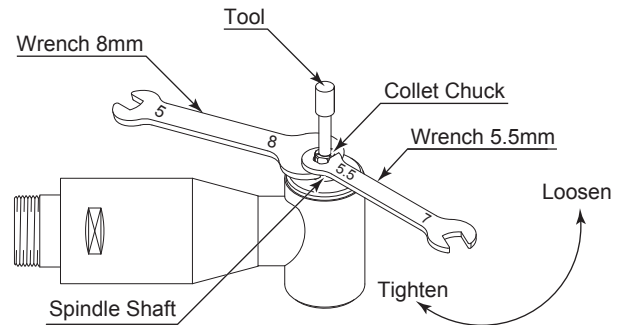

Fig. 3

6. REPLACING THE COLLET CHUCK

- ① Remove the tool according to the section "5. CHANGING THE TOOL" procedure above (Fig. 3).
- ② Place the provided 8mm wrench on the spindle shaft, and turn the top of the collet chuck counter-clockwise to remove the collet chuck (Fig. 4).
- ③ Install the new collet chuck into the Spindle by turning it clockwise.

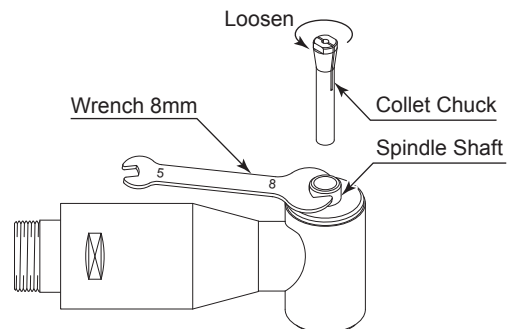

Fig. 4

7. INSTALLATION OF THE SPINDLE

⚠ WARNING

When installing a Spindle to a fixed base, make sure the fixed base is grounded in order to avoid the risk of an electric shock.

⚠ CAUTION

- When installing a Spindle, do not hit, drop or cause shock to the Spindle. This may cause damage to internal components and result in malfunctions.
- When mounting the Spindle, be sure to mounting within clamping area etched on the Spindle. If the Spindle is installed incorrectly, this will cause and damage to the Spindle.
- Cautions when tightening the securing bolt of the Split Type Holder
Do not over-tighten the bolt. This may cause damage to Spindle's precision.
Tighten the bolt until the Spindle body can not be turned by hand within the fixture.
Extreme tightening is not necessary or recommended.
Apply working force and check that the Spindle is tight before using.

- ① When mounting a Spindle, refer to the Clamping Area etched on the Spindle (Fig. 5).

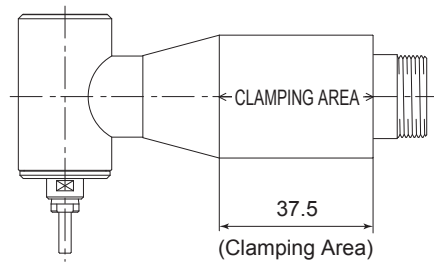

Fig. 5

- * When installing a Spindle, use a " Grip Ring GR - 30 (sold separately) " (Fig. 6) recommended. If the Grip Ring GR - 30 (sold separately) cannot be used due to the restriction of dimension and space, install as shown in ② below.

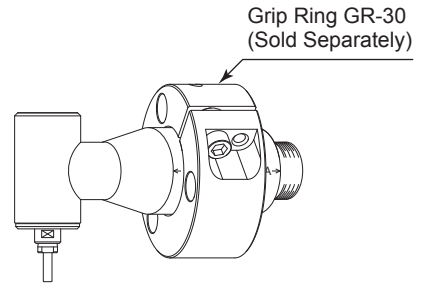

Fig. 6

- ② When installing a Spindle to the holder, recommended installation method is shown Fig. 7. Refer to " ③ How to fabricate the Split Type Holder. If this is not possible, install as shown in Fig. 8.

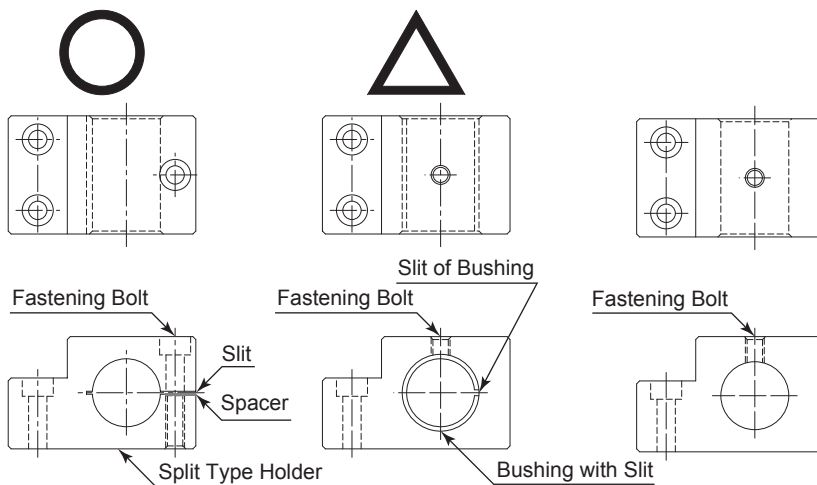

Fig. 7

Fig. 8

Fig. 9

⚠ CAUTION

Do not allow set screws to come directly in contact with the Spindle body as shown in Fig. 9, as this will result in damage to the Spindle housing and internal components. When installing, never clamp directly over the bearings, as this will result in bearing damage. (Refer to Fig. 10)

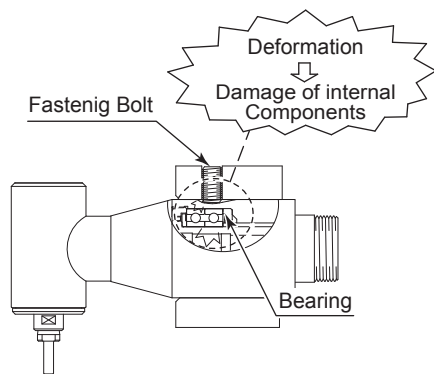

Fig. 10

- ③ How to fabricate the Split Type Holder
- (1) Rough bore the inside diameter of the Split Type Holder.
 - (2) Cut a slit. (Ex. Slit 2mm) wide
 - (3) Tighten the Screw for Removal and Force Open the Slit Area.
 - (4) Insert a spacer (Ex. thickness = 2mm) into the Slit Area.
 - (5) Loosen the Screw for Removal, and tighten the fastening bolt with the specified torque.
 - (6) Finish the Split Type Holder so that the inside diameter of the Split Type Holder is $\phi 30$ with its tolerance range from -0.01mm to -0.015mm , and its roundness and cylindricity of less than $5\mu\text{m}$.
 - (7) When inserting the Spindle loosen the Fastening Bolt and twist the Screw for Removal, and widen the Slit Area.

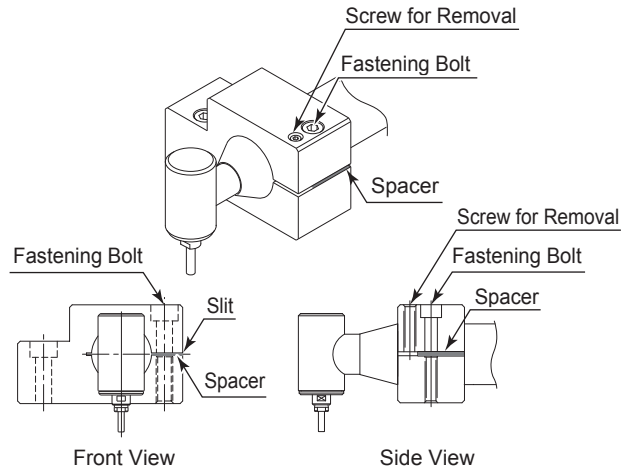

Fig. 11

CAUTION

- **How to confirm the correct tightening or clamping of the Spindles in the holder : In case of use a brushless motor.**
Measure the current value of the CONTROLLER's power cord by the clamp meter.
Fasten the holder so that the increase in the no-load current value (during rotation at the maximum rotation speed) with the Spindle fastened is 10mA (for type 200V / 230V) or less, compared to the no-load current value (during rotation at the maximum rotation speed) without fastening the Spindle. Do not over-tighten the Fastening Bolt. It may damage Spindle's precision and shorten the life of the bearings.
- **The final responsibility for ensuring holder's safety for use in a given application is left to the designer of the equipment in which NAKANISHI's Spindle is installed.**
NAKANISHI offers Spindles with a wide variety of capabilities and specifications.
Please carefully check the Spindle's specifications against the requirements of your equipment and verify suitability and safety of the Holder prior to initial use.

8. BREAK-IN PROCEDURE

During transportation, storage or installation, the grease inside the bearings will settle. If the Spindle is suddenly run at high-speed, the grease will be ejected from the bearings, causing excessive heat that will cause bearing damage. After installation, repair, initial operation, or long periods of non operation, please follow the break-in procedure detailed in Table 1.

Table 1.

Steps		1	2	3	4
Air Pressure (MPa)	For Air Motor	0.1	0.2	0.3	0.4
Rotation Speed (min^{-1}) (rpm)	For Brushless Motor	5,000	10,000	15,000	20,000
Rotation Time (min)		15	10	10	15
Items to Check		No Abnormal Noises.	The Spindle housing temperature during the break-in process should not exceed 20 degrees C (36 degrees F) above ambient temperature. Should the Spindle exceed this limit, rest the Spindle for at least 20 minutes and re-start the break in procedure from the beginning. If the housing temperature rises again and exceeds 20 degrees C (36 degrees F) above ambient temperature, check the Spindle and motor for proper installation.		The Spindle housing temperature during the break-in process should not exceed 20 degrees C (36 degrees F) above ambient temperature.

9. CAUTIONS WHEN USING GRINDSTONES AND TOOLS

⚠ CAUTION

The maximum surface speed or rpm is always specified for a grindstone. Do not exceed the maximum speed with reference to the calculating chart below. Always follow the grindstone manufacturer's recommendations.

$$\text{Surface Speed (m/s)} = \frac{3.14 \times \text{Diameter (mm)} \times \text{rotation speed (min}^{-1}\text{) (rpm)}}{1,000 \times 60}$$

- ① The proper surface speed for general grindstones is 10 - 30m / s.
- ② Do not exceed 13mm of overhang for mounted grindstones as shown in Fig. 12. If the overhang must exceed 13mm, reduce the motor speed in accordance with Table 2.
- ③ Dress the grindstone prior to use.
- ④ Do not use cutting tools with bent or broken shanks, cracks or excessive run-out.
- ⑤ For grinding, the maximum depth of cut should not exceed 0.01mm radially or axially. Reciprocate the tool several times after each pass to eliminate tool pressure.
- ⑥ Always operate cutting tools within the allowable recommended speed of the cutting tools. Use of a cutting tool outside of the allowable speed of the cutting tools could cause damage to the spindle and injury to the operator.
- ⑦ Keep the cutting tool shank and collet chuck clean. If contaminants are left in the collet chuck or chuck nut, excessive run-out will cause damage to the cutting tool and or Spindle.
- ⑧ Do not strike or disassemble the Spindle.
- ⑨ Please minimize the tool overhang amount to maintaining high accuracy. 13mm is the maximum amount of overhang to maintain high accuracy and safety.

Table 2. Overhang and Speed

Overhang (mm)	Max. Speed (min ⁻¹) (rpm)
20	N x 0.5
25	N x 0.3
50	N x 0.1

※ N=Max. Operating Speed with 13mm overhang.

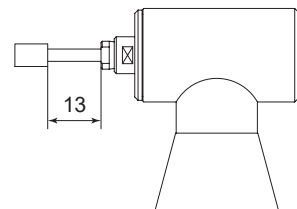

Fig. 12

10. TROUBLESHOOTING

If a problem or concern occur, please check the following items prior to consulting your dealer.

Trouble	Cause	Inspection / Corrective Action
Spindle does not rotate or rotate smoothly.	The Spindles ball bearings have been damaged.	Replace the ball bearings. (Return to NAKANISHI dealer service.)
	The motor has been damaged.	Replace the motor. (Return to NAKANISHI dealer service.)
Overheating during rotation.	Cutting debris has contaminated the ball bearings, and the ball bearings are damaged.	Replace the ball bearings. (Return to NAKANISHI dealer service.)
Abnormal vibration or noise during rotation.	The tool shank is bent.	Replace the tool.
	Cutting debris has contaminated the ball bearing.	Replace the ball bearings. (Return to NAKANISHI dealer service.)
	The Spindles ball bearings have been damaged.	
Tool slippage.	Collet chuck is not correctly installed.	Check and clean the collet chuck. Reinstall the collet chuck.
	The collet chuck is worn.	Replace the collet chuck.
High run-out.	The tool is bent.	Change the tool.
	Collet chuck is not correctly installed.	Secure the collet chuck correctly.
	The collet chuck is worn.	Replace the collet chuck.
	Inside of the Spindle is worn.	Replace the Spindle shaft. (Return to NAKANISHI dealer service.)
	Contaminants inside the collet chuck or the Spindle.	Clean the collet chuck and the inside of the taper and Spindle.
	The Spindle ball bearings has been damaged.	Replace the ball bearings. (Return to NAKANISHI dealer service.)

In case of using a Brushless Motor, refer to Brushless Motor and E3000 CONTROLLER Operation Manuals.

11. DISPOSAL OF THE SPINDLE

When disposal of a Spindle is necessary, follow the instructions from your local government agency for proper disposal of industrial components.

NAKANISHI INC. 
700 Shimohinata, Kanuma
Tochigi 322-8666
Japan
www.nakanishi-inc.com

NSK America Corp.
1800 Global Parkway
Hoffman Estates
IL 60192, USA
www.nskamericacorp.com

NSK Europe GmbH 
Elly-Beinhorn-Strasse 8
65760 Eschborn
Germany

NSK United Kingdom Ltd.
UK Authorised Representative
Office 4, Gateway 1000
Arlington Business Park, Whittle Way
Stevenage, SG1 2FP, UK