

# Ring Type Attachment IR - 310

## OPERATION MANUAL

OM-K0493E 003

Thank you for purchasing the Ring Type Attachment " IR - 310 ". This Attachment designed for powerful and delicate cutting and grinding, and made slim and light weight for comfortable gripping. The Emax EVolution control unit and motor or ROTUS air motor are required to drive this Attachment. Read this and all the associated component Operation Manuals carefully before use. Always keep this Operation Manual in a place where a user can referred to for reference at any time.

### 1. CAUTIONS FOR HANDLING AND OPERATION

- Read these warnings and cautions carefully and only use in the manner intended.
- These warnings and cautions are intended to avoid potential hazards that could result in personal injury to the operator or damage to the device. These are classified as follows in accordance with the seriousness of the risk.

Class	Degree of Risk
<b>WARNING</b>	A safety hazard could result in bodily injury or damage to the device if the safety instructions are not properly followed.
<b>CAUTION</b>	A hazard that could result in light or moderate bodily injury or damage to the device if the safety instructions are not followed.

#### WARNING

- ① This Attachment is designed for hand use. Never install this Attachment or any hand tool on a machine such as a special purpose machine, NC lathe or mill.
- ② Do not touch the cutting tool while it is rotating. It is very dangerous.
- ③ Wear safety glasses, dust mask, and use a protective cover around the Spindle whenever the Spindle is rotating.
- ④ When installing a cutting tool, tighten the collet correctly and check again the collet before use. Do not over-tighten the collet. This may cause damage to the spindle.
- ⑤ Do not use grindstones with an outside diameter over  $\phi 15\text{mm}$ .
- ⑥ Do not exceed 13mm of overhang for mounted grindstones as shown in Fig. 1. If the overhang must exceed 13mm, reduce the motor speed in accordance with Table. 1.
- ⑦ Do not use bent, broken, chipped, out of round or sub-standard cutting tools as they may cause shatter or explode. The cutting tool with cracked, bended may cause some injury to operator. When using a new cutting tool, rotate it in a low speed and increase speed gradually for safety.
- ⑧ Always operate cutting tools within the cutting tool manufacturer's recommended speed limits. Use of a cutting tool higher than the manufacturer's recommended speed limits could cause damage to the spindle and injury to the operator.
- ⑨ Do not apply excessive force. This may cause tool slippage, tool damage, injury to the operator, loss of concentricity and precision.

Table. 1 Overhang and Speed

Overhang (mm)	Max. Speed ( $\text{min}^{-1}$ ) (rpm)
20	N x 0.5
25	N x 0.3
50	N x 0.1

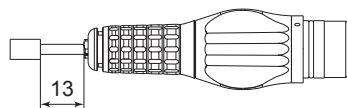

Fig. 1

\*N=Max. Operating Speed with 13mm overhang.

#### CAUTION

- ① Do not drop or hit this Attachment, as shock can damage to the internal components.
- ② Be sure to clean the collet, the spindle taper and threads before replacing the cutting tool. If ground particles or metal chips stick to the inside of spindle or the collet, damage to the collet or spindle can occur due to the loss of precision.
- ③ When cleaning an Attachment, stop the motor and remove dirt with a brush or a cloth. Do not blow compressed air into the Attachment. Foreign particles or cutting chips may get into the ball bearings.
- ④ Always clean the cutting tool shank before installing the tool in the spindle.
- ⑤ When sizing the correct collet size to the cutting tool shank diameter, a tolerance of  $+0 \sim -0.01\text{mm}$  is strongly recommended. A tool shank within the  $+0 \sim -0.1\text{mm}$  range is mountable, however, this may cause poor concentricity and or insufficient cutting tool shank gripping force.

#### CAUTION

- ⑥ Select suitable products or cutting tools for each application. Do not exceed the capabilities of the Attachment or cutting tools.
- ⑦ Keep everything in order not to place the rag which could be caught near the hand tool.
- ⑧ Stop operating immediately when abnormal rotation or any unusual vibrations are observed. Afterwards, please check the content of section " 10. TROUBLESHOOTING ".
- ⑨ Always check if the cutting tool, collet is damaged before and after operating.
- ⑩ If the collet show signs of wear or damage, replace it before a malfunction or additional damage occurs.
- ⑪ No lubrication is required because grease impregnated ball bearings are used.
- ⑫ After installation, repair, initial operation, or long periods of non operation, please carry out break-in as follow. Start rotating slowly and over a short period of 5 - 10 minutes, increase speed gradually until allowable maximum speed.
- ⑬ Do not disassemble, modify or attempt to repair the Attachment. Additional damage will occur to the internal components. Service must be performed by NSK NAKANISHI or an authorized service center.

### 2. BASIC PACKAGE

When opening the package, check if it includes all items listed in " Table. 2 Packing List Contents ".

In the event of any shortage, please contact either NAKANISHI (see the " 4. CONTACT US " section) or your local dealer.

Table. 2 Packing List Contents

IR - 310 Attachment • • 1pc. 	Collet $\phi 3.0\text{mm}$ (CHH - 3.0)* or $\phi 2.35\text{mm}$ (CHH - 2.35) • • Each 1pc. CHH - 2.35 	Wrench (7 x 5.1) • • 1pc. 
Pin Wrench (K - 233) • • 1pc. 	L Shaped Wrench • • 1pc. 	Operation Manual • • 1set 

\* The collet is attached to the Attachment.

### 3. WARRANTY

We provide a limited warranty for our products. We will repair or replace the products if the cause of failure is due to the following manufactures defects. Please contact us or your local distributor for details.

- ① Defect in manufacturing.
- ② Any shortage of components in the package.
- ③ Where damaged components are found when initially opening the package.  
(This shall not apply if the damage was caused by the negligence of a customer.)

### 4. CONTACT US

For your safety and convenience when purchasing our products, we welcome your questions.

If you have any questions about operation, maintenance and repair of the product, please contact us.

#### Contact Us

- For U.S. Market

Company Name

: **NSK America Corp.**

Industrial Div.

Business Hours

: 8:00 to 17:00 (CST)

(closed Saturday, Sunday and Public Holidays)

U.S. Toll Free No.

: +1 800 585 4675

Telephone No.

: +1 847 843 7664

Fax No.

: +1 847 843 7622

Website

: www.nskamericacorp.com

- For Other Markets

Company Name

: **NAKANISHI INC.**

Business Hours

: 8:00 to 17:00 (JST)

(closed Saturday, Sunday and Public Holidays)

Telephone No.

: +81 289 64 3520

e-mail

: webmaster-ie@nsk-nakanishi.co.jp

## 5. FEATURES

- ① Ring type (twist) chucking system makes it easier to change tools.
- ② The slim style, light weight Attachment is the best suited instrument for delicate finish work.

## 6. SPECIFICATIONS AND DIMENSIONS

### 6 - 1 Specifications

Model	IR - 310		
Maximum Allowable Motor Speed	Less than 40,000min <sup>-1</sup> (rpm)		
Applicable Motor	ENK - 410S / ENK - 250T (Emax EVolution) IM-301 (ROTUS air motor)		
Vibration Level	Less than 2.5m/s <sup>2</sup>		
Weight	92g		
Noise Level at 1m distance	Less than 70dB (A)		

	Temperature	Humidity	Atmospheric Pressure
Operation Environment	0 - 40°C	MAX.75% (No condensation)	800 - 1,060hPa
Transportation and Storage Environment	-10 - 50°C	10 - 85%	500 - 1,060hPa

<Option>

Collet (CHH- □□)	φ 1.0mm, φ 1.5mm, φ 1.6mm, φ 2.0mm, φ 2.35mm φ 3.0mm, and φ 3.175mm
---------------------	--

### 6 - 2 Outside View

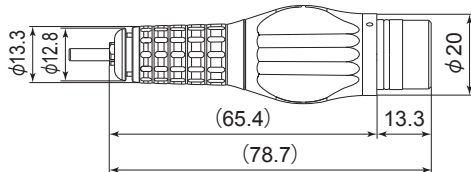

Fig. 2

## 7. CONNECTION OF THE ATTACHMENT TO THE MOTOR

### CAUTION

**Make sure your hands and all interlocking parts of the Attachment and motor are clean before connecting the motor to the Attachment. This is critical in preventing contaminants from entering the motor or Attachment.**

Align the thread on the front end of the motor and the rear end Attachment, and turn the Attachment clockwise. If the drive shaft of the motor does not engage properly to the drive dog on the Attachment, it may only turn approximately two threads before stopping. **DO NOT FORCE THEM TOGETHER.** Loosen the Attachment from the motor, rotate the Attachment shaft by hand then re-try. The drive shaft and the drive dog must be fully engaged. When fully engaged, secure the motor and Attachment using the provided pin wrench (K - 233).

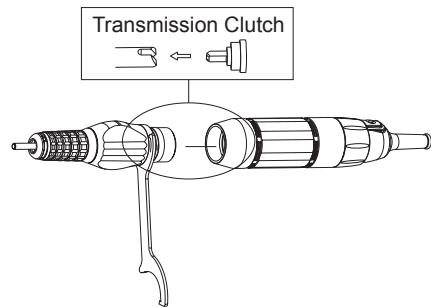

Fig. 3

## 8. CHANGING THE CUTTING TOOL

### CAUTION

- When Ring is OPEN position, do not rotate the motor. This may cause breakdown to the motor and Attachment. Be sure to confirm the ring position is LOCK position, before rotating the motor.
- Do not ring turn to the LOCK position, without inserting a cutting tool or dummy bur, as this will result in damage to the collet.

Turn the ring to the direction of OPEN, and the collet will be loosened and the bur could be removed. Turn the ring to the direction of LOCK, and the collet will be fastened and the cutting tool could be mounted. Make 'clank' when the ring is turned (Fig. 4).

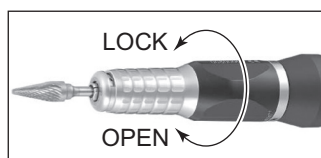

Fig. 4

## 9. REPLACING AND CLEANING COLLET

### ① Replacing the collet

Turn the collet counterclockwise with the ring opened, and the collet will be removed (Fig. 5).

If it is hard to remove the collet, use the provided wrench.

\* The collet might be fastened and the cutting tool could not be removed, if the cutting tool with large diameter is used under a high torque. Align the nose's slit and Attachment's wrench position, and put an L shaped wrench to fix the Attachment. Open the ring, remove the dust proof cap to the tip of the collet and turn the collet counterclockwise with a wrench for replacing collets to remove it (Fig. 6).

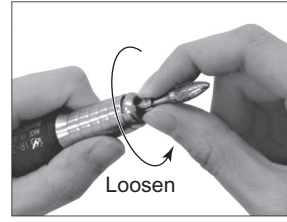

Fig. 5

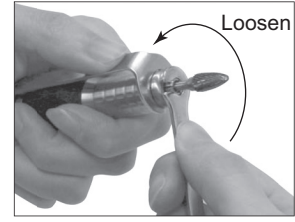

Fig. 6

### ② Cleaning the collet

Keep the collet clean. It is recommended to clean the collet at least a week. Coat oil lightly on the collet before putting it back into the Attachment.

### ③ Mounting and adjusting the collet.

Turn the cutting tool / the dummy bur clockwise to stop with the ring opened. Return it about 1/5 ~ 1/4 to remove the cutting tool / the dummy bur smoothly (Fig. 7).

\* Adjust the cutting tool referring to ③, if it is easy and/or difficult to remove the cutting tool.

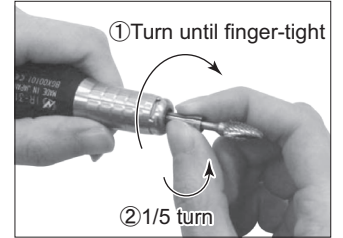

Fig. 7

## 10. TROUBLESHOOTING

If a problem or concern occur, please check the following items prior to consulting your dealer.

Trouble	Cause	Inspection / Corrective Action
Spindle does not run with the collet tightened. (Ring is LOCK position)	Cutting debris has contaminated the ball bearing, or the ball bearing is out burned.	Replace the ball bearings. (Return to NAKANISHI dealer service.)
Spindle does not rotate or rotate smoothly.	The spindles ball bearings are damaged.	Replace the ball bearings. (Return to NAKANISHI dealer service.)
	The motor has been damaged.	Replace the motor. (Return to NAKANISHI dealer service.)
	The ring is OPEN position.	Turn the ring to LOCK position.
Overheating during rotation.	Cutting debris has contaminated the ball bearing, and the ball bearings are damaged.	Replace the ball bearings. (Return to NAKANISHI dealer service.)
Abnormal vibration or noise during rotation.	Using bent cutting tool.	Replace the cutting tool.
	Cutting debris has contaminated the ball bearings.	Replace the ball bearings. (Return to NAKANISHI dealer service.)
	The spindles ball bearings are damaged.	
Cutting tool slippage.	Collet is not correctly installed.	Check and clean the collet. Reinstall the collet and re-tighten. Check the accuracy.
	The collet is worn.	Replace the collet.
High run-out.	Cutting tool is bent.	Replace the cutting tool.
	The collet is worn.	Replace the collet.
	Inside of the spindle is worn.	Replace the spindle shaft. (Return to NAKANISHI dealer service.)
	Contaminants inside the collet or the spindle.	Clean the collet and the inside of the spindle.
It is not possible to mount / remove the cutting tool.	The spindles ball bearings are damaged.	Replace the ball bearings. (Return to NAKANISHI dealer service.)
	Chucking system is broken.	Repair the chucking system. (Return to NAKANISHI dealer service.)
	The ring is not turned until OPEN or LOCK position.	Turn the ring to OPEN or LOCK position.
	The cutting tool is fixed to the collet.	Remove the cutting tool by using wrench. (Refer to section "9. REPLACING AND CLEANING COLLET")

## 11. DISPOSAL OF THE ATTACHMENT

When disposal of an Attachment is necessary, follow the instructions from your local government agency for proper disposal of industrial components.

**NAKANISHI INC.** www.nakanishi-inc.com  
700 Shimochinata, Kanuma, Tochigi 322-8666, Japan  
**NSK America Corp.** www.nskamericacorp.com  
1800 Global Parkway, Hoffman Estates, IL 60192, USA  
**NSK Europe GmbH**   
Elly-Beinhorn-Strasse 8, 65760 Eschborn, Germany  
**NSK United Kingdom Ltd.** UK Authorised Representative  
Office 4, Gateway 1000, Arlington Business Park  
Whittle Way, Stevenage, SG1 2FP, UK