

Automatic Tool Replacement Spindle NR50-5100 ATC

OPERATION MANUAL

OM-K0537E 005

Thank you for purchasing Automatic Tool Replacement Spindle " NR50-5100 ATC ". This Spindle is designed for suited for PCB drilling. The E3000 CONTROLLER, Brushless Motor and Air Line Kit are required to drive this Spindle. Read this and all the associated component Operation Manuals carefully before use. Always keep this Operation Manual in a place where a user can referred to for reference at any time.

1. CAUTIONS FOR HANDLING AND OPERATION

- Read these warnings and cautions carefully and only use in the manner intended.
- These warnings and cautions are intended to avoid potential hazards that could result in personal injury to the operator or damage to the device. These are classified as follows in accordance with the seriousness of the risk.

Class	Degree of Risk
WARNING	A safety hazard could result in bodily injury or damage to the device if the safety instructions are not properly followed.
CAUTION	A hazard that could result in light or moderate bodily injury or damage to the device if the safety instructions are not followed.

WARNING

- ① The Spindle is not a hand tool. It is designed to be used on CNC machines or special purpose machines.
- ② Do not touch the cutting tool while it is running. It is very dangerous.
- ③ Wear safety glasses, dust mask, and use a protective cover around the Spindle whenever the Spindle is rotating.
- ④ Never connect, disconnect or touch the Power Cord Plug or Motor Cord Plug with wet hands. This may cause an electric shock.
- ⑤ Never operate or handle the Spindle and brushless motor until you have thoroughly read the Operation Manuals and safe operation has been confirmed.
 - 1) To prevent injuries / damages, check the Spindle, brushless motor and cutting tool for proper installation, before operating the Spindle and brushless motor.
 - 2) Before disconnecting the Spindle and brushless motor, always turn the control power off and turn the compressed air supply to the CONTROLLER off. Then it is safe to remove the Spindle and brushless motor.
- ⑥ When installing a Spindle to a fixed base, make sure the fixed base is grounded in order to avoid the risk of an electric shock.
- ⑦ When installing a tool, tighten the collet correctly and check again the collet before use. Do not over-tighten the collet. This may cause damage to the spindle.
- ⑧ Do not open and close the collet while the brushless motor is running.
- ⑨ Do not use bent, broken, chipped, out of round or sub-standard tools, as this may cause them to shatter or explode. Tools with fractures or a bent shank will cause injury to the operator. When using a new tool, rotate it in a low speed and increase speed gradually for safety.
- ⑩ Do not exceed the maximum recommended allowable tool speed. For your safety, use speeds below the maximum allowable speed.
- ⑪ Do not apply excessive force. This may cause tool slippage, tool damage, injury to the operator or loss of concentricity and precision.

CAUTION

- ① Do not drop or hit this Spindle, as shock can damage to the internal components.
- ② Do not connect this Spindle to the reduction gear. This may cause collet breakage by overload.
- ③ Be sure to clean the collet, the inside of the spindle before replacing the tool. If ground particles or metal chips stick to the inside of spindle or the collet, damage to the collet or spindle can occur due to the loss of precision.
- ④ When cleaning a Spindle, stop the brushless motor and remove debris with a soft brush or a cloth. Do not blow air into the End of Spindle Area (refer to section " 6 - 2 Outside View ") with compressed air as foreign particles or cutting debris may get into the ball bearing.
- ⑤ Always clean the tool shank before installing the tool in the spindle.
- ⑥ When sizing the correct collet size to the tool shank diameter, a tolerance of +0 ~ - 0.01mm is strongly recommended. A tool shank within the +0 ~ - 0.1mm range is mountable, however, this may cause poor concentricity and or insufficient tool shank gripping force.
- ⑦ Select suitable products or tools for all applications. Do not exceed the capabilities of the Spindle or tools.
- ⑧ Do not stop the supply cooling air for motor during operation of the machine. Removing the air pressure from the Motor / Spindle causes a loss of purging, allowing the Motor / Spindle to ingest coolant. This will cause damage to the Motor / Spindle.
- ⑨ Carefully direct coolant spray to the tool. Do not spray directly on the Spindle body. If large amount spray directly on the Spindle, it may cause excess load of the motor rotation with loss of durability to the Spindle.
- ⑩ Stop working immediately when abnormal rotation or unusual vibration are observed. Immediately, please check the content of section " 14. TROUBLESHOOTING ".
- ⑪ Always check if the tool, collet, connection hose and supply air hose for damaged before and after operating.
- ⑫ If the collet show signs of wear or damage, replace it before a malfunction or additional damage occurs.
- ⑬ After installation, repair, initial operation, or long periods of non operation, please refer to section " 12. BREAK-IN PROCEDURE " detailed in Table. 2. When checking the Spindle, no vibration or unusual sound should be observed during rotation.
- ⑭ Do not disassemble, modify or attempt to repair this Spindle . Additional damage will occur to the internal components. Service must be performed by NSK NAKANISHI or an authorized service center.
- ⑮ When using this Spindle for mass production, please consider the purchase of an additional Spindle to be used as a back-up in case of emergency.

2. BASIC PACKAGE

When opening the package, check if it includes all items listed in " Table. 1 Packing List Contents ". In the event of any shortage, please contact either NAKANISHI (see the " 4. CONTACT US " section) or your local dealer.

Table. 1 Packing List Contents

NR50 - 5100 ATC • • 1pc. 	Collet ϕ 3.175mm (CHR - 3.175) • • 1pc.* (For U.S. market ϕ 3.175mm (CHR - 3.175)) 	Bar Wrench (K - 236) • • 1pc.
Wrench (9 x 11), (12 x 14) • • Each 1pc. 	Air Hose with Filter (ϕ 6mm x 2m) • • 1pc. 	Inspection Card • • 1pc.
Operation Manual • • 1set 	* The collet is attached to the Spindle.	

3. WARRANTY

We provide a limited warranty for our products. We will repair or replace the products if the cause of failure is due to the following manufactures defects. Please contact us or your local distributor for details.

- ① Defect in manufacturing.
- ② Any shortage of components in the package.
- ③ Where damaged components are found when initially opening the package. (This shall not apply if the damage was caused by the negligence of a customer.)

4. CONTACT US

For your safety and convenience when purchasing our products, we welcome your questions. If you have any questions about operation, maintenance and repair of the product, please contact us.

Contact Us

● For U.S. Market	Company Name : NSK America Corp. Industrial Div. Business Hours : 8:00 to 17:00 (CST) (closed Saturday, Sunday and Public Holidays) U.S. Toll Free No. : +1 800 585 4675 Telephone No. : +1 847 843 7664 Fax No. : +1 847 843 7622 Website : www.nskamericacorp.com
● For Other Markets	Company Name : NAKANISHI INC. Business Hours : 8:00 to 17:00 (JST) (closed Saturday, Sunday and Public Holidays) Telephone No. : +81 289 64 3520 e-mail : webmaster-ie@nsk-nakanishi.co.jp

5. FEATURES

- ① The tools can be replaced automatically by putting ON - OFF the air.
- ② The Spindle housing is made from precision ground, hardened, stainless steel (SUS) with an outside diameter of ϕ 50mm.
- ③ The collet size is ϕ 2.0mm, ϕ 3.0mm, ϕ 3.175mm, ϕ 4.0mm, ϕ 6.0mm, ϕ 6.35mm.

6. SPECIFICATIONS AND DIMENSIONS

6 - 1 Specifications

Model	NR50 - 5100 ATC		
Maximum Motor Rotation Speed	50,000min ⁻¹ (rpm)		
Spindle Accuracy	Less than 1 μ m		
Applicable Motor	EM - 3060, EM - 3060J / EM - 3060J - 2M, EM - 3030J / EM - 3030J - 2M *This Spindle can not use the reduction gear.		
Milling Capacity (Cutting or Milling PC boards with an end mill.)	End Mill Size	: Less than ϕ 2.0mm	
	Work	: PC board (ex. Glass Epoxy Resin)	
	Thickness	: Less than 1.6mm	
	F	: Less than 3,000mm / min	
Weight	1,370g		
Noise Level at 1m distance	Less than 70dB (A)		

* You may need to lower feed rate (mm / min) depending on the shape of tools being used or the thickness of work. Always check the milling condition before working.

	Temperature	Humidity	Atmospheric Pressure
Operation Environment	0 - 40°C	MAX.75% (No condensation)	700 - 1,060hPa
Transportation and Storage Environment	-10 + 50°C	10 - 85%	500 - 1,060hPa

<Option>

Collet (CHR - □□)	ϕ 2.0mm, ϕ 3.0mm, ϕ 3.175mm, ϕ 4.0mm, ϕ 6.0mm, ϕ 6.35mm
--------------------	---

6 - 2 Outside View

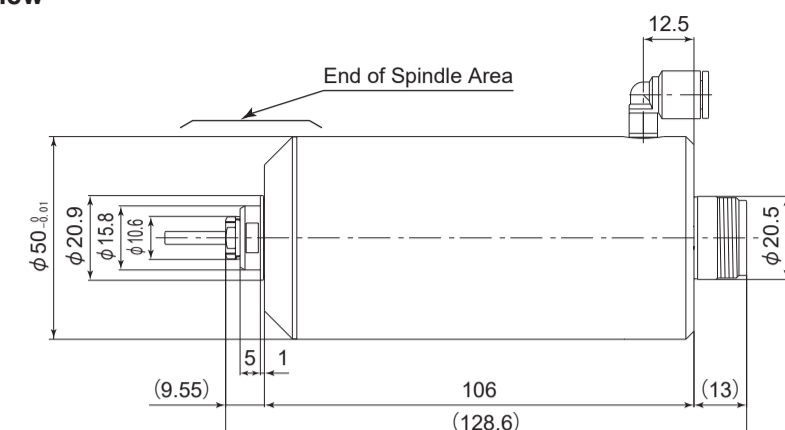

Fig. 1

7. CONNECTION OF THE SPINDLE TO THE BRUSHLESS MOTOR

CAUTION

Make sure your hands and all interlocking parts of the Spindle and brushless motor are clean before connecting the Spindle to the brushless motor. This is critical in preventing contaminants from entering the Spindle or brushless motor.

Align the thread on the front end of the brushless motor and the rear of the Spindle, and turn the Spindle clockwise. If the drive shaft of the brushless motor does not engage properly to the drive dog on the Spindle, it may only turn approximately two threads before stopping. DO NOT FORCE THEM TOGETHER. Loosen the Spindle from the brushless motor, rotate the Spindle shaft by hand then re-try. The drive shaft and the drive dog must be fully engaged. When fully engaged, secure the brushless motor and Spindle using the provided 27mm wrench (Fig. 2).

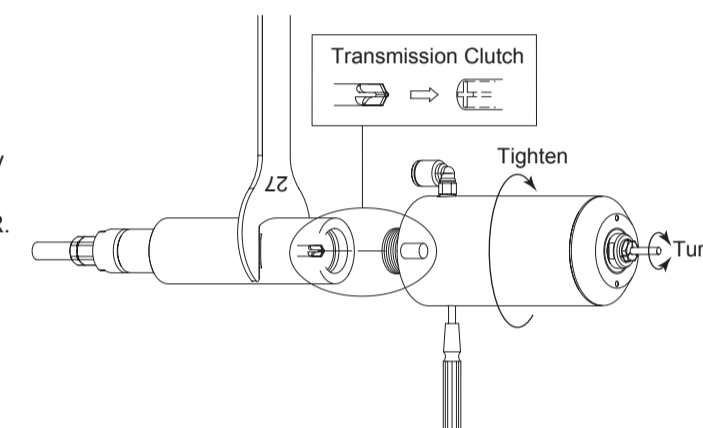

Fig. 2

8. CONNECTION OF AIR HOSE AND AIR SUPPLY

CAUTION

Securely connect the air hose to the brushless motor and air line kit to avoid accidental disconnection and injury to the operator during use.

- ① Connect the provided ϕ 6mm Air Hose with filter and 3-way valve to Air Inlet Joint shown in Fig. 3.
- ② Supply clean air from air compressor through air filter or air dryer to the 3-way valve at the set air pressure : from 0.55 - 0.6MPa (79.8 - 87psi).

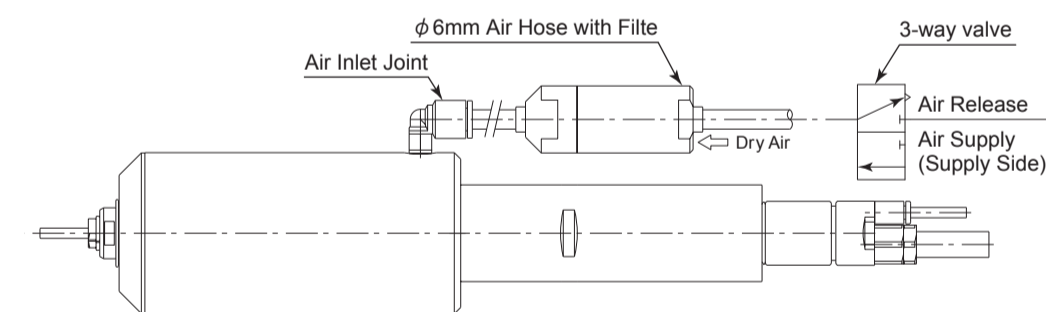

Fig. 3

(When using the rear air inlet joint)

CAUTION

- The rear air inlet port is closed with an M5 screw before shipment. When changing the air inlet port location, remove the M5 screw to install an air inlet joint.
- Use any one of the two air inlet port. Be sure to close the unused air inlet port with the removed M5 screw.
- After installing the fitting, supply air and confirm that there is no air leakage, then proceed with the installation.

- Please purchase the recommended commercially available air inlet fitting for the air inlet joint.

Recommended air inlet	SMC is KQS04 - M5.	ϕ 6mm to ϕ 4mm tubing reducer	SMC is KQH04 - 06.
-----------------------	--------------------	---	--------------------

- When installing the collet clamp / unclamp fittings, thoroughly read the instructions before connecting. (Fig. 4)

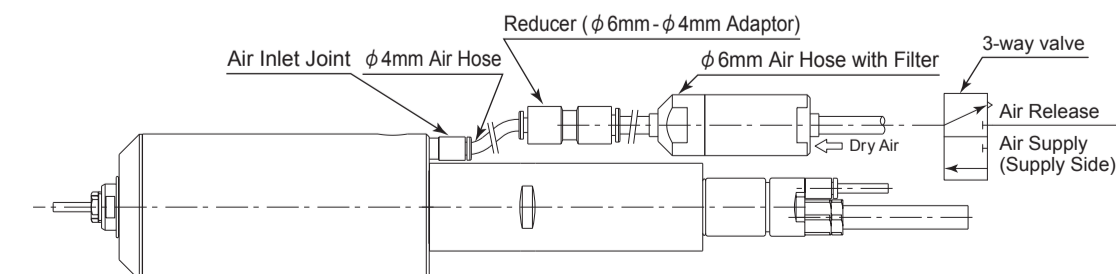

Fig. 4

9. CHANGING THE TOOL

⚠ WARNING

Do not open and close the collet while the brushless motor is running.

⚠ CAUTION

- When the air is supplied to the inlet joint of the Spindle, the tool will be pushed out by exhausting the coolant air of brushless motor from the edge of Spindle. Be careful not to be damaged to the tool or be injured.
- Use the air on-off valve through which the air can be exhausted. Do not use 2 way valve, because the 2 way valve is not exhausted and the collet is not closed.
- Do not open and close the collet before the tool is not installed. Because this will cause damage to the collet or loss of precision.

RECOMMENDATION

Please set the cutting tools to minimize the overhang amount. 13mm is the maximum amount of overhang to maintain high accuracy and safety.

- ① Stop the motor. (Or check if the motor is stopped)
- ② Supply air pressure : from 0.55 - 0.6MPa (79.8 - 87psi) to Air Inlet Joint through 3-way valve. Then, the collet will be opened. At the same time, the tool is pushed out by the air exhaust for the coolant of motor. So, need the tool holder not to be damaged to the tool.
- ③ Replace the tool.
- ④ Exhaust the air through 3-way valve. The collet will be closed and the tool can be fixed.

10. REPLACING THE COLLET

⚠ CAUTION

Collet will be worn and torn if it will be opened and closed about 5,000 - 10,000 times. Replace it with the new collet at this time.

- ① Stop the coolant air of motor.
- ② Supply air pressure : from 0.55 - 0.6MPa (79.8 - 87psi) to Air Inlet Joint to keep the collet opened. Do not take off the tool when the air pressure is supplied
- ③ Place the provided wrench 14mm on the wrench hook of the spindle shaft, and tighten the Spindle.
- ④ Place the provided wrench 9mm on the collet and turn it counterclockwise to loosen the collet. And take off the collet with the tool from the spindle shaft.
- ⑤ Remove the tool from another collet.
- ⑥ Insert the tool into another collet and turn it clockwise to be attached on the spindle shaft.
- ⑦ Tight it lightly with the provided wrench 14mm and wrench 9mm (Specified tightening torque : 1.0 N · m).
- ⑧ Exhaust the air through 3-way valve.
- ⑨ After the collet is replaced, supply the coolant air of motor to the motor.

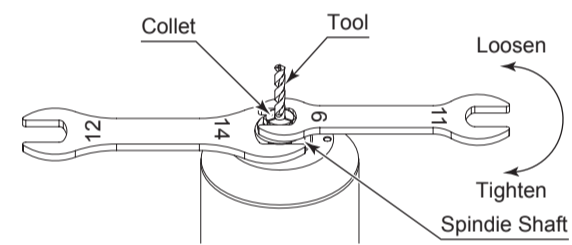

Fig. 5

11. INSTALLATION OF THE SPINDLE

⚠ WARNING

When installing a Spindle to a fixed base, make sure the fixed base is grounded in order to avoid the risk of an electric shock.

⚠ CAUTION

- When installing a Spindle, do not hit, drop or cause shock to the Spindle. This may cause damage to internal components and result in malfunctions.
- When mounting the Spindle, be sure to secure within Clamping Area etched on the Spindle O.D. If the Spindle is installed incorrectly, damage to the internal components is possible.
- Cautions when tightening the securing bolts on to a Split Type Holder. Do not over-tighten the bolt. This will cause damage to Spindle's precision. Tighten the bolt until the Spindle body can not be rotated by hand within the fixture. Extreme tightening is not necessary or recommended. Apply working force and check that the Spindle is tight before using.

- ① When mounting a Spindle, refer to the Clamping Area etched on the Spindle (Fig. 6).
- ② When installing a Spindle to the holder, recommended installation method is shown Fig. 7. Refer to "③ How to fabricate the Split Type Holder". If this is not possible, install as shown in Fig. 8.

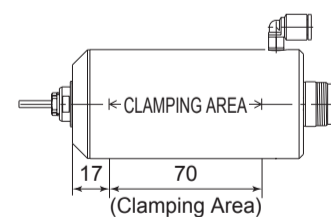

Fig. 6

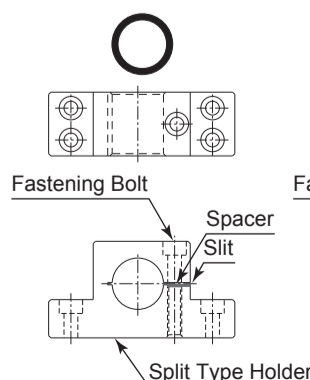

Fig. 7

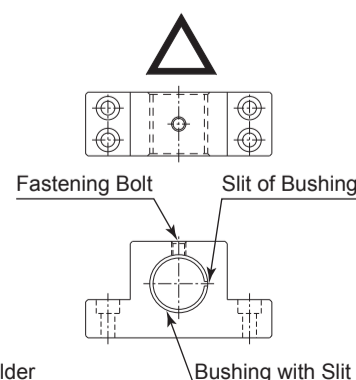

Fig. 8

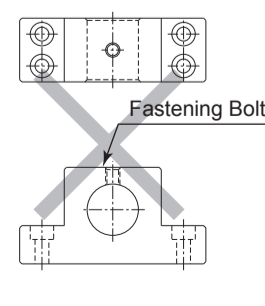

Fig. 9

⚠ CAUTION

Do not allow set screws to come directly in contact with the Spindle body as shown in Fig. 9, as this will result in damage to the Spindle housing and internal components. When installing, never clamp directly over the bearings, as this will result in bearing damage. (Refer to Fig. 10)

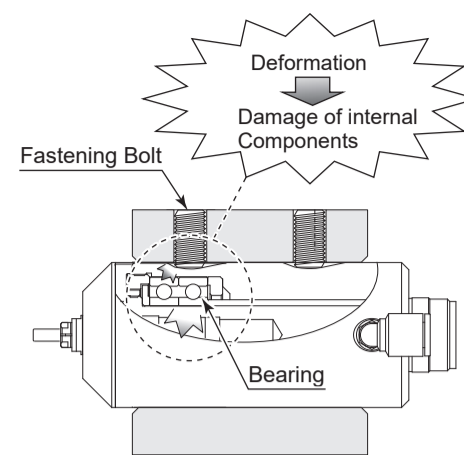

Fig. 10

- ③ How to fabricate the Split Type Holder.
 - (1) Rough bore the inside diameter of the Split Type Holder.
 - (2) Cut a slit. (Ex. Slit 2mm) wide.
 - (3) Tighten the Screw for Removal and Force Open the Slit Area.
 - (4) Insert a spacer (Ex. thickness = 2mm) into the Slit Area.
 - (5) Loosen the Screw for Removal, and tighten the fastening bolt with its specified torque.
 - (6) Finish the Split Type Holder so that the inside diameter of the Split Type Holder is $\phi 50$ with its tolerance range from - 0.01mm to - 0.015mm, and its roundness and cylindricity of less than 5 μ m.
 - (7) When inserting the Spindle loosen the Fastening Bolt, and tighten the Screw for Removal, widening the Slit Area.

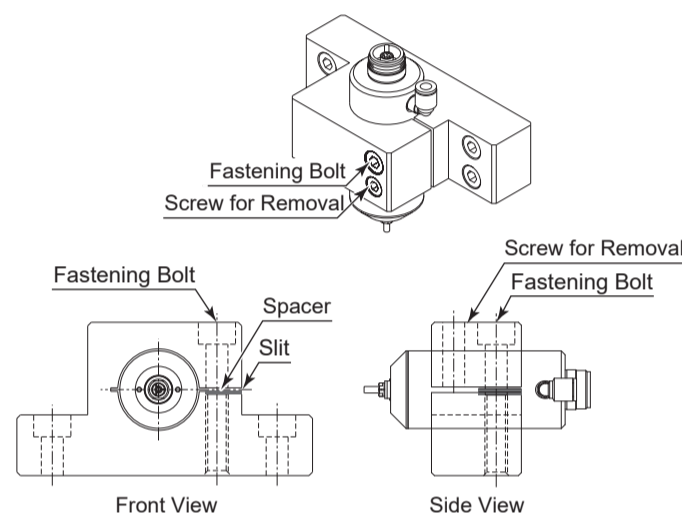

Fig. 11

⚠ CAUTION

- How to confirm the correct tightening or clamping of the Spindles in the holder : Measure the current value of the CONTROLLER's power cord by the clamp meter. Fasten the holder so that the increase in the no-load current value (during rotation at the maximum rotation speed) with the Spindle fastened is 10mA (for type 200V / 230V) or less, compared to the no-load current value (during rotation at the maximum rotation speed) without fastening the Spindle. Do not over-tighten the Fastening Bolt. It may damage Spindle's precision and shorten the life of the bearings.
- The final responsibility for ensuring holder's safety for use in a given application is left to the designer of the equipment in which NAKANISHI's Spindle is installed. NAKANISHI offers Spindles with a wide variety of capabilities and specifications. Please carefully check the Spindle's specifications against the requirements of your equipment and verify suitability and safety of the Holder prior to initial use.

12. BREAK-IN PROCEDURE

During transportation, storage or installation, the grease inside the bearings will settle. If the Spindle is suddenly run at high-speed, the grease will be ejected from the bearings, causing excessive heat that will cause bearing damage. After installation, repair, initial operation, or long periods of non operation, please follow the break-in procedure detailed in Table. 2.

Table. 2

Steps	1	2	3	4
Rotation Speed (min ⁻¹) (rpm)	15,000	30,000	40,000	50,000
Rotation Time (min)	15	10	10	15
Items to Check	No Abnormal Noises	The Spindle housing temperature during the break-in process should not exceed 20 degrees C (36 degrees F) above ambient temperature. Should the Spindle exceed this limit, rest the Spindle for at least 20 minutes and restart the break in procedure from the beginning. If the housing temperature rises again and exceeds 20 degrees C (36 degrees F) above ambient temperature, check the Spindle and motor for proper installation.	The Spindle housing temperature during the break-in process should not exceed 20 degrees C (36 degrees F) above ambient temperature.	

13. CAUTIONS WHEN USING GRINDSTONES AND TOOLS

⚠ CAUTION

The maximum surface speed or rpm is always specified for a grindstone. Do not exceed the maximum speed with reference to the calculating chart below. Always follow the grindstone manufacturer's recommendations.

$$\text{Surface Speed (m / s)} = \frac{3.14 \times \text{Diameter (mm)} \times \text{Rotation Speed (min}^{-1}\text{) (rpm)}{1,000 \times 60}$$

- ① The proper surface speed for general grindstones is 10 - 30m/s.
- ② Do not exceed 13mm of overhang for mounted grindstones as shown in Fig. 12. If the overhang must exceed 13mm, reduce the motor speed in accordance with Table. 3.
- ③ Dress the grindstone prior to use.
- ④ Do not use cutting tools with bent or broken shanks, cracks or excessive run-out.
- ⑤ For grinding, the maximum depth of cut should not exceed 0.01mm radially or axially. Reciprocate the tool several times after each pass to eliminate tool pressure.
- ⑥ Always operate cutting tools within the allowable recommended speed of the cutting tools. Use of a cutting tool outside of the allowable speed of the cutting tools could cause damage to the Spindle and injury to the operator.
- ⑦ Keep the cutting tool shank and collet clean. If contaminants are left in the collet or collet nut, excessive run-out will cause damage to the cutting tool and or Spindle.
- ⑧ Do not strike or disassemble the Spindle.
- ⑨ Please set the cutting tools to minimize the overhang amount. 13mm is the maximum amount of overhang to maintain high accuracy and safety.

Table. 3 Overhang and Speed

Overhang (mm)	Max. Speed (min ⁻¹) (rpm)
20	N x 0.5
25	N x 0.3
50	N x 0.1

N = Max. Operating Speed with 13mm overhang.

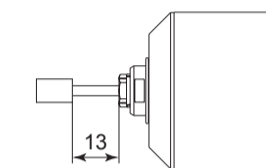

Fig. 12

14. TROUBLESHOOTING

If a problem or concern occurs, please check the following prior to consulting your dealer.

Trouble	Cause	Inspection / Corrective Action
Spindle does not rotate or rotate smoothly.	The Spindle ball bearings have been damaged.	Replace the ball bearings. (Return to NAKANISHI dealer service.)
	The motor has been damaged.	Replace the motor. (Return to NAKANISHI dealer service.)
Overheating during rotation.	Cutting debris has contaminated the ball bearing, and the ball bearings are damaged.	Replace the ball bearings. (Return to NAKANISHI dealer service.)
Abnormal vibration or noise during rotation.	The tool shank is bent.	Replace the tool.
	Cutting debris has contaminated the ball bearing. The Spindle ball bearings have been damaged.	Replace the ball bearings. (Return to NAKANISHI dealer service.)
Tool slippage.	Collet is not correctly installed.	Check and clean the collet. Reinstall the collet.
	The collet is worn.	Replace the collet.
High run-out.	The tool is bent.	Change the tool.
	Collet is not correctly installed.	Secure the collet correctly.
	The collet is worn.	Replace the collet.
	Inside of the Spindle is worn.	Replace the spindle shaft. (Return to NAKANISHI dealer service.)
	Contaminants inside the collet or the Spindle. The Spindle ball bearings have been damaged.	Clean the collet and the inside of the taper and Spindle. Replace the ball bearings. (Return to NAKANISHI dealer service.)
Check can not be opened and closed.	Poor the air hose.	Check all threaded joints and re-tighten if necessary.
	The air hose have been damaged.	Replace the air hoses.
	Low air pressure.	Check and adjusting the air circuit.
	Error connection of the air circuit.	

Refer to Brushless Motor and E3000 CONTROLLER Operation Manuals.

15. DISPOSAL OF THE SPINDLE

When disposal of a Spindle is necessary, follow the instructions from your local government agency for proper disposal of industrial components.

NAKANISHI INC.
700 Shimohinata, Kanuma
Tochigi 322-8666
Japan
www.nakanishi-inc.com

NSK America Corp.
1800 Global Parkway
Hoffman Estates
IL 60192, USA
www.nskamericacorp.com

NSK Europe GmbH
Elly-Beinhorn-Strasse 8
65760 Eschborn
Germany

NSK United Kingdom Ltd.
UK Responsible Person
Office 4, Gateway 1000
Arlington Business Park, Whittle Way
Stevenage, SG1 2FP, UK