

クイックチェンジスピンドル / Quick Change Spindle

NRR4040-QC

取扱説明書 / OPERATION MANUAL

日本語 : P1 - P14 / English : P17 - P32

OM-K0640 002





Thank you for purchasing the NRR4040-QC Quick Change Spindle. This spindle features easy replacement of the collet holder in the spindle by lever operation. The spindle is designed for grinding, small diameter drilling and milling, etc.. The <E4000 CONTROLLER>, <E4000 Series Brushless Motor>, and <Air Line Kit> are required to drive this spindle. Read these Operation Manuals carefully before installing and operating. Always keep this Operation Manual in a place where a user can referred to for reference at any time.

CONTENTS

1. CAUTIONS FOR HANDLING AND OPERATION	P18
2. FEATURES	P20
3. SPECIFICATIONS AND DIMENSIONS	P20
4. CONNECTION TO THE MOTOR	P22
5. CHANGING THE TOOL AND REPLACING THE COLLET CHUCK	P22
6. REPLACING THE COLLET HOLDER	P25
7. INSTALLATION OF THE SPINDLE	P26
8. BREAK-IN PROCEDURE	P29
9. CAUTIONS WHEN USING GRINDSTONES AND TOOLS	P30
10. TROUBLESHOOTING	P31

1. CAUTIONS FOR HANDLING AND OPERATION

- Read these warnings and cautions carefully and only use in the manner intended.
- These warnings and cautions are intended to avoid potential hazards that could result in personal injury to the operator or damage to the device. These are classified as follows in accordance with the seriousness of the risk.

Class	Degree of Risk
 WARNING	A safety hazard could result in bodily injury or damage to the device if the safety instructions are not properly followed.
 CAUTION	A hazard that could result in light or moderate bodily injury or damage to the device if the safety instructions are not followed.

WARNING

- ① This spindle is not a hand tool. It is designed to be used on CNC machines or special purpose machines.
- ② Do not touch the cutting tool while it is running. It is very dangerous.
- ③ Wear safety glasses, dust mask and use a protective cover around the spindle whenever the spindle is rotating.
- ④ Never connect, disconnect or touch the Power Cord Plug and Motor Cord Connector with wet hands. This may cause an electric shock.
- ⑤ Stop the motor prior to operating the lever. If lever operation is performed during spindle rotation, contact with internal components will damage the spindle.
- ⑥ Never operate or handle the spindle until you have thoroughly read the Operation Manuals and safe operation has been confirmed.
 - 1) To prevent injuries / damages, check the spindle and cutting tool for proper installation, before operating the spindle.
 - 2) Before disconnecting the spindle, always turn the control power off and turn the compressed air supply to the CONTROLLER off. Then it is safe to remove the spindle.
- ⑦ When installing a spindle to a fixed base, make sure the fixed base is grounded in order to avoid the risk of an electric shock.
- ⑧ When mounting the collet holder on the spindle, make sure the lever is in LOCK position before rotating the spindle.
- ⑨ When installing a tool in the collet holder, tighten the collet chuck correctly then re-check the collet chuck and chuck nut before operating. Do not over-tighten the collet chuck. This may cause damage to the collet holder.



WARNING

- ⑩ Do not use bent, broken, chipped, out of round or sub-standard tools, as this may cause them to shatter or explode. Tools with fractures or a bent shank will cause injury to the operator. When using a new tool, rotate it in a low speed and increase speed gradually for safety.
- ⑪ Do not exceed the maximum recommended allowable tool speed. For your safety, use speeds below the maximum allowable speed.
- ⑫ Do not apply excessive force. This may cause tool slippage, tool damage, injury to the operator or loss of concentricity and precision.



CAUTION

- ① Do not drop or hit this spindle, as shock can damage to the internal components.
- ② When replacing the collet holder, make sure the inner face of the spindle and taper surfaces of the collet holder are clean. (Clean them if debris is found.) Ground particles or metal chips stuck to the surface will cause run-out or damage to the collet chuck and spindle. Loss of concentricity will cause spindle damage due to the lack of precision.
- ③ When cleaning a spindle, stop the motor and remove debris with a soft brush or a cloth. Do not blow air into the spindle with compressed air as foreign particles or cutting debris may get into the ball bearing.
- ④ When replacing the tool, make sure the tool shank, collet chuck, chuck nut and inner face of the collet holder are clean. If ground particles or metal chips stick to the inside of the collet chuck, damage to the collet holder or spindle can occur due to the loss of precision.
- ⑤ When sizing the correct collet chuck size to the tool shank diameter, a tolerance of $+0 \sim -0.01\text{mm}$ is strongly recommended. A tool shank within the $+0 \sim -0.1\text{mm}$ range is mountable, however, this may cause poor concentricity and or insufficient tool shank gripping force.
- ⑥ Select suitable products or tools for all applications. Do not exceed the capabilities of the spindle or tools.
- ⑦ Carefully direct coolant spray to the tool. Do not spray directly on the collet holder and spindle body.
- ⑧ Stop working immediately when abnormal rotation or unusual vibration are observed. Afterwards, please check the content of section " 10. TROUBLESHOOTING ".
- ⑨ Always check if the tool, collet chuck are damaged before and after operating.
- ⑩ If the collet chuck, chuck nut or the collet holder show signs of wear or damage, replace them before a malfunction or additional damage occurs.

<Option>

Collet Holder	QC5 - K	QC5 - 16
Collet Chuck	CHK - □□	CH16 - □□
	φ0.5mm - 6.0mm in 0.1mm increments and φ2.35mm, φ3.175mm and φ6.35mm	φ3.0mm, φ3.175mm, φ4.0mm, φ6.0mm, φ6.35mm, φ8.0mm and φ10.0mm
Chuck Nut	K - 265	CHN - 16
Wrench	12 x 14 (2 pcs. Required.)	17 x 22 (2 pcs. Required)
Preset Adapter	QC5 - K ADP	QC5 - 16 ADP

3 - 2 Outside View

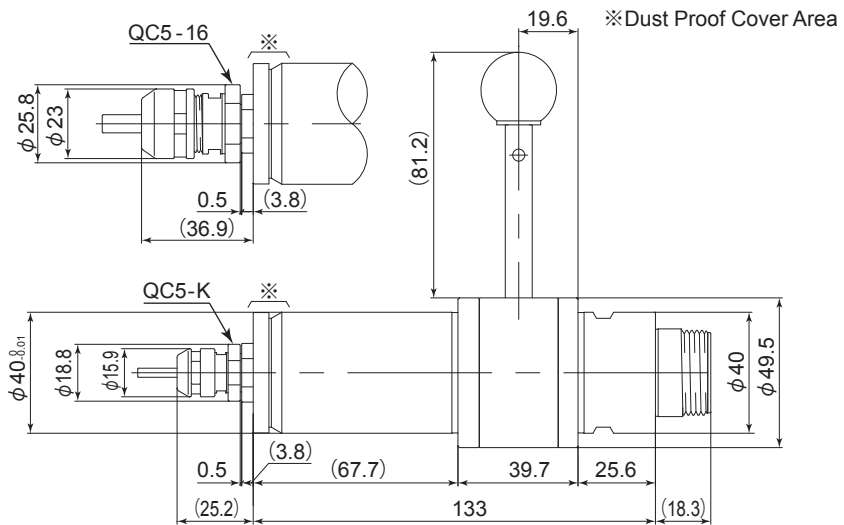

Fig 1

4. CONNECTION OF THE SPINDLE TO THE MOTOR

⚠ CAUTION

- Make sure your hands and all interlocking parts of the spindle and motor are clean before connecting the motor to the spindle. This is critical to prevent contaminants from entering the motor or spindle.
- When connecting the spindle to the motor, it is best to hold the motor and spindle in a vertical position. Carefully connect by threading the motor on the spindle and avoid mis-alignment, as this will cause damage to the motor and or spindle drive.

Align the threads on the front end of the motor and the rear end of the spindle, then rotate the spindle clockwise. If the drive shaft of the motor does not engage the drive dog on the spindle, it will not be possible for the spindle to rotate. **DO NOT FORCE THIS CONNECTION.** Turn the spindle back a few threads, rotate the collet cap or spindle shaft slightly by hand until the drive shaft and the drive dog are fully engaged. This may take several attempts. Use the 36mm wrench that have been provided for the final tightening of the spindle to the motor.

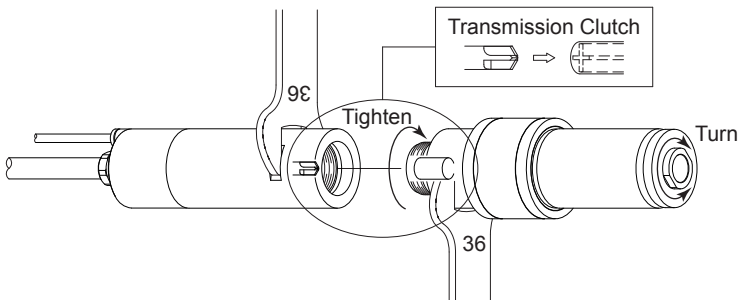

Fig 2

5. CHANGING THE TOOL AND REPLACING THE COLLET CHUCK

⚠ CAUTION

- Do not tighten the collet chuck without inserting a tool or dummy bur, as this will damage the collet chuck, spindle or chuck nut, causing difficulty removing the collet chuck.
- When installing the collet chuck in the chuck nut, make sure to fully engage the latch inside the chuck nut to the groove on the collet chucks outer circumference area. In addition, remember that if the collet chuck is attached without being engaged with the latch of the chuck nut, the collet chuck cannot be removed and this may cause damage to the collet chuck or the spindle.

RECOMMENDATION

Please minimize the tool overhang amount to maintaining high accuracy.

5 - 1 How to replace collets chuck using the provided wrenches

- ① Attach the chuck to the chuck nut. Be sure to fully engage the latch inside the chuck nut to the groove on the collet chucks outer circumference area. (Fig. 3, Fig. 4) (Install the collet chuck in the chuck nut by positioning the collet chuck in the chuck nut and pressing down on flat surface. (Fig. 5))
- ② Attach the collet chuck and chuck nut to the collet holder and lightly finger tighten. (Do not completely tighten until the end.) (Fig. 6)
- ③ Insert the tool in to the collet chuck and position the wrench on the collet holder. Position the wrench on the chuck nut, then tighten the chuck nut by turning clockwise. (Fig. 7)
- ④ When removing the tool, set the wrench on the chuck nut and turn it counterclockwise to loosen the collet chuck and remove the tool. (The first turn will loosen the chuck nut, but the tool will not release and turning will become stiff. Keep turning through the stiffness and the collet chuck will open.)
- ⑤ When removing the collet chuck, the collet chuck and chuck nut are secured by a groove in the collet chuck and a flange in the chuck nut. To remove the collet chuck hold the chuck nut in one hand and push diagonally down on the collet chuck. The collet chuck should be released. (Fig. 5).

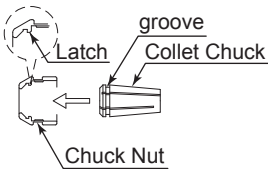

Fig 3

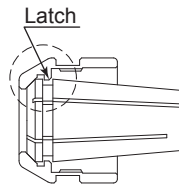

Fig 4

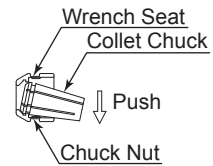

Fig 5

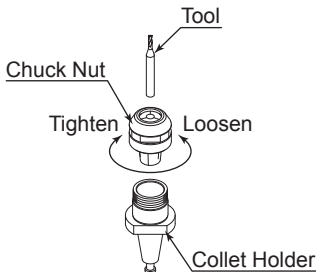

Fig 6

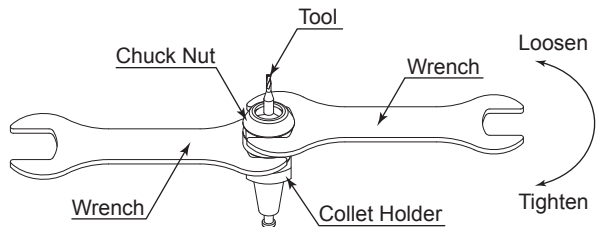

Fig 7

5 - 2 Tool replacement using a preset adapter

- ① Affix the preset adapter to the tool holder ($\phi 20\text{mm}$) etc.
- ② Align the collet holder to the drive dog notch of the preset adapter, and insert the collet holder. (Fig. 8)
- ③ Attach the collet chuck and chuck nut to the collet holder, and lightly finger tighten. (Do not tighten until the end.) (Fig. 9)
- ④ Insert the tool in to the collet chuck and set the wrench on the collet holder. Set the wrench on the chuck nut, and tighten the chuck nut by turning clockwise. (Fig. 10)
- ⑤ When removing the tool, set the wrench on the chuck nut and turn it counterclockwise to loosen the collet chuck and remove the tool. (The first turn will loosen the chuck nut, but the tool will not release and turning will become stiff. Keep turning through the stiffness and the collet chuck will open.)

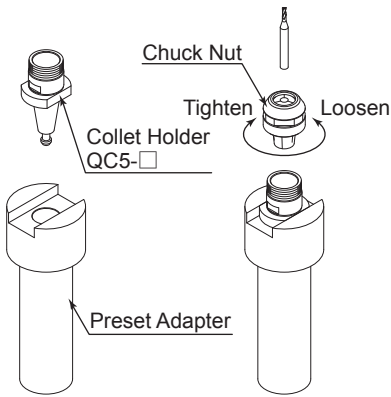

Fig 8

Fig 9

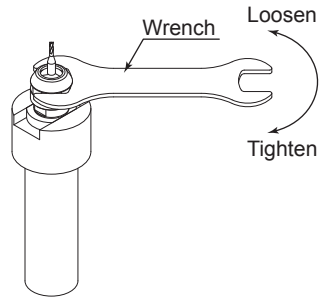

Fig 10

6. REPLACING THE COLLET HOLDER

⚠ CAUTION

When replacing the collet holder, be sure to stop the spindle. If the lever is operated while the spindle is rotating, the spindle will incur internal damage.

- ① Stop the spindle rotation and confirm the rotation has stopped.
- ② Rotate the lever 90-Degrees to the OPEN position (matching " OPEN ● " mark and the " ● " mark position). The collet holder will then be free for removal.
- ③ Insert the new collet holder. Rotate the " ● " mark of the lever to the " ● LOCK " mark position all the way until it snaps in position to tighten the collet holder.

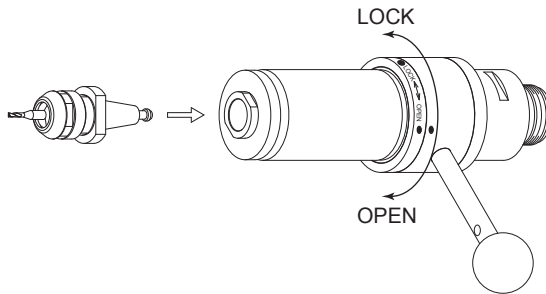

Fig 11

- ④ When installing the collet holder into the spindle using an automatic tool changer (and other machines), set the collet holder a distance of 1.2 - 1.8mm from the face of the spindle.

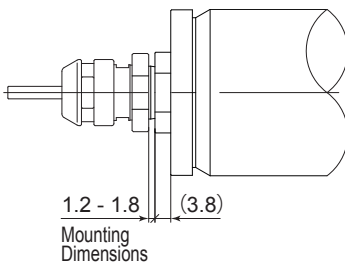

Fig. 12 Before Clamping

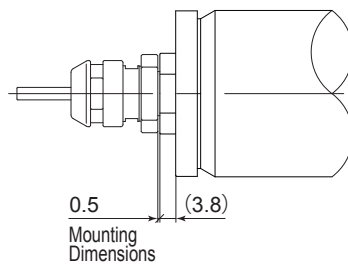

Fig. 13 After Clamping

7. INSTALLATION OF THE SPINDLE

⚠ WARNING

Whenever connecting a spindle to an electric motor, or when installing a spindle to a fixed base, ensure that the fixed base is grounded in order to avoid risk of an electric shock.

⚠ CAUTION

- When installing a spindle, do not hit, drop or cause shock to the spindle. This may cause damage to internal components and result in malfunctions.
- When mounting the spindle, be sure to mounting within clamping area etched on the spindle. If the spindle is installed incorrectly, this will cause and damage to the spindle.
- Cautions when tightening the securing bolt of the Split Type Holder
Do not over-tighten the bolt. This may cause damage to spindle's precision.
Tighten the bolt until the spindle body can not be turned by hand within the fixture.
Extreme tightening is not necessary or recommended.
Apply working force and check that the spindle is tight before using.

① When mounting a spindle, refer to the Clamping Area etched on the spindle. (Fig. 14)

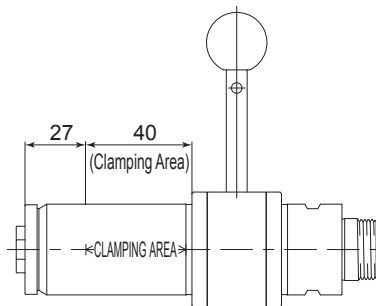

Fig. 14

- ② When installing a spindle to the holder, recommended installation method is shown Fig 15. Refer to "③ How to fabricate the Split Type Holder ". If this is not possible, install as shown in Fig. 16.

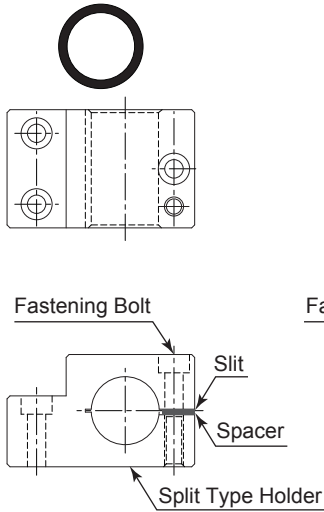

Fig. 15

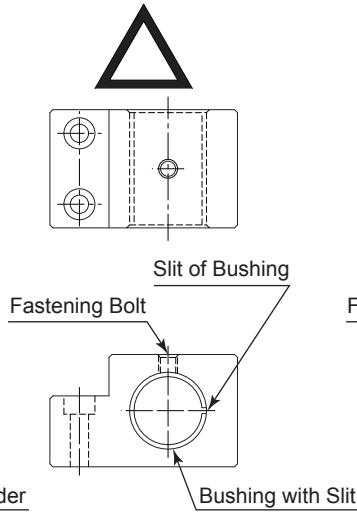

Fig. 16

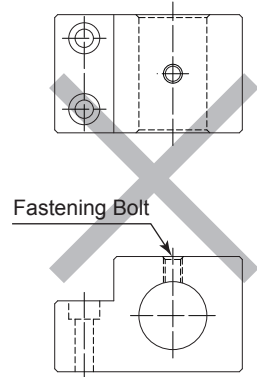

Fig. 17

! CAUTION

Do not allow set screws to come directly in contact with the spindle body as shown in Fig. 17, as this will result in damage to the spindle housing and internal components. When installing, never clamp directly over the bearings, as this will result in bearing damage. (Refer to Fig. 18)

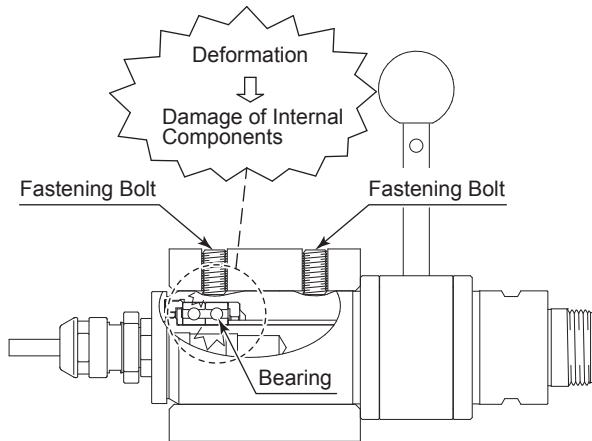

Fig. 18

③ How to fabricate the Split Type Holder

- (1) Rough bore the inside diameter of the Split Type Holder.
- (2) Cut a slit. (Ex. Slit 2mm) wide
- (3) Tighten the Screw for Removal and Force Open the Slit Area.
- (4) Insert a spacer (Ex. thickness = 2mm) into the Slit Area.
- (5) Loosen the Screw for Removal, and tighten the fastening bolt with the specified torque.
- (6) Finish the Split Type Holder so that the inside diameter of the Split Type Holder is $\phi 40$ with its tolerance range from -0.01mm to -0.015mm , and its roundness and cylindricity of less than $5\mu\text{m}$.
- (7) When inserting the spindle loosen the Fastening Bolt and twist the Screw for Removal, and widen the Slit Area.

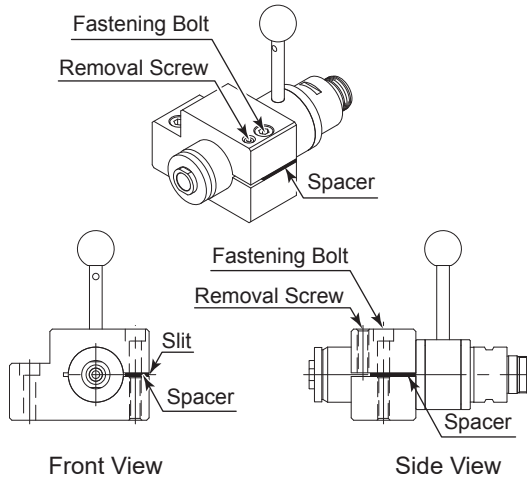

Fig. 19

CAUTION

- How to confirm the correct tightening or clamping of the spindles in the holder: Measure the current value of the CONTROLLER's power cord by the clamp meter. Fasten the holder so that the increase in the no-load current value (during rotation at the maximum rotation speed) with the spindle fastened is 10mA (for type 200V / 230V) or less, compared to the no-load current value (during rotation at the maximum rotation speed) without fastening the spindle. Do not over-tighten the Fastening Bolt. It may damage spindle's precision and shorten the life of the bearings.
- The final responsibility for ensuring holder's safety for use in a given application is left to the designer of the equipment in which NAKANISHI's spindle is installed. NAKANISHI offers spindles with a wide variety of capabilities and specifications. Please carefully check the spindle's specifications against the requirements of your equipment and verify suitability and safety of the Holder prior to initial use.

8. BREAK-IN PROCEDURE

During transportation, storage or installation, the grease inside the bearings will settle. If the spindle is suddenly run at high-speed, the grease will be ejected from the bearings, causing excessive heat that will cause bearing damage.

After installation, repair, initial operation, or long periods of non operation, please follow the break-in procedure detailed in Table 1.

Table 1.

Steps	1	2	3	4
Rotation Speed (min ⁻¹)	10,000	20,000	30,000	40,000
Rotation Time (min)	15	10	10	15
Items to Check	No Abnormal Noises	The spindle housing temperature during the break-in process should not exceed 20 degrees C (36 degrees F) above ambient temperature. Should the spindle exceed this limit, rest the spindle for at least 20 minutes and re-start the break in procedure from the beginning. If the housing temperature rises again and exceeds 20 degrees C (36 degrees F) above ambient temperature, check the spindle and motor for proper installation.	The spindle housing temperature during the break-in process should not exceed 20 degrees C (36 degrees F) above ambient temperature.	

9. CAUTIONS WHEN USING GRINDSTONES AND TOOLS —

⚠ CAUTION

The maximum surface speed or rpm is always specified for a grindstone. Do not exceed the maximum speed with reference to the calculating chart below. Always follow the grindstone manufacturer's recommendations.

$$\text{Surface Speed (m / s)} = \frac{3.14 \times \text{Diameter (mm)} \times \text{Rotation Speed (min}^{-1}\text{)}}{1,000 \times 60}$$

- ① The proper surface speed for general grindstones is 10 - 30m / s.
- ② Do not exceed 13mm of overhang for mounted grindstones as shown in Fig. 20. If the overhang must exceed 13mm, reduce the motor speed in accordance with table 2.
- ③ Dress the grindstone prior to use.
- ④ Do not use cutting tools with bent or broken shanks, cracks or excessive run-out.
- ⑤ For grinding, the maximum depth of cut should not exceed 0.01mm radially or axially. Reciprocate the tool several times after each pass to eliminate tool pressure.
- ⑥ Always operate cutting tools within the allowable recommended speed of the cutting tools. Use of a cutting tool outside of the allowable speed of the cutting tools could cause damage to the spindle and injury to the operator.
- ⑦ When replacing the tool, make sure the tool shank, collet chuck, chuck nut, and inner face of the collet holder are clean. If ground particles or metal chips stick to the inside of the collet chuck, damage to the collet holder or spindle can occur due to the loss of precision.
- ⑧ Do not strike or disassemble the spindle.
- ⑨ Please minimize the tool overhang amount to maintaining high accuracy. 13mm is the maximum amount of overhang to maintain high accuracy and safety.

Table 2. Overhang and Speed

Overhang (mm)	Max. Speed (min ⁻¹)
20	N x 0.5
25	N x 0.3
50	N x 0.1

* N = Max. Operating Speed with 13mm overhang.

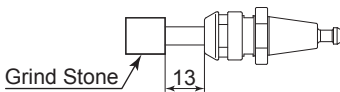

Fig. 20

10. TROUBLESHOOTING

If a problem or concern occurs, please check the following prior to consulting your dealer.

Trouble	Cause	inspection / Corrective Action
Spindle does not rotate or rotate smoothly.	The spindles bearings have been damaged.	Replace the ball bearings. (Return to NAKANISHI dealer service.)
	The motor has been damaged.	Replace the motor. (Return to NAKANISHI dealer service.)
	Lever position is OPEN.	Set the lever to the LOCK position.
Overheating during rotation.	Cutting debris has contaminated the ball bearings, and the ball bearings are damaged.	Replace the ball bearings. (Return to NAKANISHI dealer service.)
	The lever is not set to the LOCK position.	Replace parts. (Return to NAKANISHI dealer service.)
Abnormal vibration or noise during rotation.	The tool is bent.	Replace the tool.
	Cutting debris has contaminated the ball bearing.	Replace the ball bearings. (Return to NAKANISHI dealer service.)
	The spindles bearings have been damaged.	
Collet holder slippage.	The collet holder is worn.	Replace the collet holder.
	The internal components of the spindle are worn or damaged.	Replace the internal components of the spindle. (Return to NAKANISHI dealer service.)
Tool slippage.	Collet chuck or chuck nut are not correctly installed.	Check and clean the collet chuck and chuck nut. Reinstall the collet chuck and chuck nut.
	The collet chuck and the chuck nut are worn.	Replace the collet chuck and chuck nut.
High run-out.	The tool is bent.	Change the tool.
	Chuck nut is not correctly installed.	Secure the collet chuck and the chuck nut correctly.
	The collet chuck, chuck nut or collet holder are worn.	Replace the collet chuck, chuck nut or collet holder.

Trouble	Cause	inspection / Corrective Action
High run-out.	Inside of the spindle is worn.	Replace the spindle shaft. (Return to NAKANISHI dealer service.)
	Contaminants inside the collet chuck, chuck nut and collet holder or the spindle.	Clean the collet chuck, chuck nut and collet holder or the spindle.
	The ball bearings are worn.	Replace the ball bearings. (Return to NAKANISHI dealer service.)

株式会社ナカニシ www.nakanishi-inc.com

〒322-8666 栃木県鹿沼市下日向700
TEL: 0289-64-3380 FAX: 0289-62-5636

NAKANISHI INC.  www.nakanishi-inc.com

700 Shimohinata, Kanuma, Tochigi 322-8666, Japan

NSK America Corp. www.nskamericacorp.com

1800 Global Parkway, Hoffman Estates, IL 60192, USA

NSK Europe GmbH 

Elly-Beinhorn-Strasse 8, 65760 Eschborn, Germany

NSK United Kingdom Ltd. UK Responsible Person

Office 4, Gateway 1000, Arlington Business Park, Whittle Way, Stevenage, SG1 2FP, UK

本書の内容は、改善のため予告なしに変更することがあります。

Contents are subject to change without notice.