

エアラインキット / Air Line Kit  
**AL - M1203BS2**

---

**取扱説明書 / OPERATION MANUAL**

日本語：P1 - P8 / English：P11 - P18



OM-K0652 001

Thank you for purchasing the Air Line Kit " AL - M1203BS2 ". This Air Line Kit is designed to adjust the air flow supply and provide automatic oil mist lubrication to the air tool. An air motor, spindle and compressor are required along with this Air Line Kit.

Read this and all the associated component Operation Manuals carefully before use. Always keep this Operation Manual in a place where a user can referred to for reference at any time.

## 1. CAUTIONS FOR HANDLING AND OPERATION

- Read these warnings and cautions carefully and only use in the manner intended.
- These warnings and cautions are intended to avoid potential hazards that could result in personal injury to the operator or damage to the device. These are classified as follows in accordance with the seriousness of the risk.

Class	Degree of Risk
 <b>WARNING</b>	<b>A safety hazard could result in bodily injury or damage to the device if the safety instructions are not properly followed.</b>
 <b>CAUTION</b>	<b>A hazard that could result in light or moderate bodily injury or damage to the device if the safety instructions are not followed.</b>

### **WARNING**

#### ① Handling

Connection to the Air Line Kit should be performed by a person with experience with compressed air and air compressors.

#### ② Air Pressure

Compressed air is required. Do not exceed an air pressure of 1.0MPa at primary side and 0.85MPa at secondary side of the Air Line Kit.

#### ③ Use of Clean Air

Do not use compressed air contaminated with chemicals, oil compounds, organic solvents, salinity or corrosive gasses in order to avoid damage to the device.

#### ④ Connection of connection hose and supply air / oil hose

Connect the input connection hose and supply air / oil hose securely to avoid accidental disconnection during use. Input air pressure should never exceed 1.0MPa.

Pressure exceeding 1.0MPa may cause the connection hose and supply air / oil hose to rupture.

#### ⑤ Inlet and Outlet Connections

Do not hit, impact or cause shock to the Inlet or Outlet Connector Connections. Never put undo stress or load on the Inlet or Outlet Connector Connections. Any damage to these components can cause air leakage and the inability of the inlet or outlet quick disconnect to adequately secure the connection hose and supply air / oil hose.

#### ⑥ Mounting the Air Line Kit

When installing the Air Line Kit, securely install the Air Line Kit by mounting it on a flat, level surface. If the Air Line Kit is dropped, damage to the Air Line Kit and injury to the operator is possible.

#### ⑦ Electric shock

Do not touch the connection terminal, during operation of the Air Line Kit, this may cause an electric shock.

#### ⑧ Air Regulator Bowl

- The bowl is made of a polycarbonate.

Do not use the Air Line Kit in conditions where chemicals or organic solvents are present in the atmosphere.

- Do not remove the bowl guard. Using the Air Line Kit without the bowl guard may cause injury to the operator should the bowl burst.

- When removing the bowl from the regulator, remove all pressure from the Input and Outlet sides of the Air Line Kit.

## **⚠ CAUTION**

- ① **Use of dry air**  
Using compressed air containing excessive moisture could result in malfunction or failure of the spindle and air motor. If excessive moisture or condensation are found in Air Filter Bowl, it will be necessary to install a dryer and larger Air Filter on the primary side of the Air Line Kit to prevent and remove excessive moisture.
- ② **Draining**  
Be sure to drain moisture and condensation from Air Filter Bowl regularly to avoid moisture being carried to the spindle and air motor.
- ③ **Installation Location**  
Place this Air Line Kit on a flat and level surface.  
If mounting on a wall, check if the wall is flat, and securely mount the Air Line Kit in a horizontal direction.
- ④ **Handling**  
When removing the Bowl or Oil Reservoir for cleaning, carefully remove them as not to cause damage to them.
- ⑤ **Connection of Solenoid Operated Valve and Alarm Buzzer**  
Do not use the power voltage of the more than DC+24V, this will cause damage to the Solenoid Operated Valve or Alarm Buzzer of the Air Line Kit.  
Be sure to use the power source voltage of DC+24V.

## **⚠ CAUTIONS for STORAGE, INSTALLATION and OPERATION**

- ① **Do not use the Air Line Kit where corrosive gasses, chemicals, seawater, water, oils or steam exist.**
- ② **Do not place in direct sunlight.**
- ③ **Do not use where the Air Line Kit is subject to vibration or repetitive shock.**
- ④ **Do not use where a heat source or radiated heat exist.**
- ⑤ **To conform to " STORAGE, INSTALLATION and OPERATION " (Refer to " 3. SPECIFICATIONS ").**

## **2. FEATURES**

- ① The Air Filter traps small amounts of water and impure substances from the input air supply. This Air Line Kit is not intended to be used or replace an Air Dryer.
- ② Provides stable air flow and proper air pressure to the tool by using an adjustable Regulator.
- ③ The oil mist supplied from lubricator to the Air Tool and Reducer will prolong their service life due to lubrication and the reduction of heat and friction.
- ④ Equipment with " Auto Drain Mechanism ", automatically draining the drain in the filter.
- ⑤ The Solenoid Operated Valves (DC+24V : 2pcs) can be operated by an M-Code Signal from the CNC machine tool. This Air Line Kit allows for operation of (2) two air motors.
- ⑥ Equipped with a low lubrication oil level " Alarm Buzzer ", signaling the need to fill with Lubricating Oil.

### 3. SPECIFICATIONS

Model	AL - M1203BS2		
Primary Air Pressure	Less than 1.0MPa		
Secondary Air Pressure	Less than 0.85MPa		
Maximum Operation Pressure	1.0MPa		
Maximum Peak Pressure	Less than 1.5MPa		
Maximum Peak Pressure at Hose Connection	Less than 1.0MPa		
Filtration of the Air Filter	0.3μm		
Drain Reservoir Capacity	80cm <sup>3</sup>		
Automatic Drain Least Operation Pressure	0.1MPa		
Safe Pressure Regulator Operating Range	0.05 ~ 0.85MPa		
Pressure Relief	Automatic Relief Valve		
Applied Lubricating Oil	ISO VG15, Liquid Paraffin, or equivalent		
Oil Reservoir Capacity	170cm <sup>3</sup>		
Dimensions	W490 × D101 × H320mm		
Weight	3.9Kg		
Operation Environment	Temperature	0 - 40°C	
	Humidity	MAX. 75% (No condensation)	
	Atmospheric Pressure	800 - 1,060hPa	
Transportation and Storage Environment	Temperature	-10 - 50°C	
	Humidity	10 - 85%	
	Atmospheric Pressure	500 - 1,060hPa	

#### < Solenoid Operating Valves >

Maximum Operating Pressure	0.6MPa		
Heat-Resistant Class	Class B		
Valve Seat Leakage	Less than 0.2cm <sup>3</sup> / min		
Rated Voltage	DC+24V		
Rated Power	Frequency	50Hz	60Hz
	Normal Amp Draw	7.5VA	5.5VA
	Starting Amp Draw	20VA	17VA
Power Consumption	6.5W		
Protection Structure	IP65 Suitability		

#### < Alarm Buzzer >

Power Source Voltage	DC+24V
Sound Pressure	68 ~ 75dB (1m)
Protection Structure	IP34

### Standard Accessories

- Connection Hose • • 1pc.
- Hexagon Socket Bolt (M8 X 20L) • • 4pcs.
- Operation Manual • • 1set.
- Lubricating oil (K - 202) 1ℓ • • 1pc.
- Spacer • • 4pcs.

< Option >

Lubricating Oil

Use ISO VG15 Liquid Paraffin (Shell Ondina Oil #15) in the Air Line Kit lubricator bowl. (For U.S.A. specification, use Chevron Superla #9).

Model
• Lubricating Oil (K - 211) 70cc
• Lubricating Oil (K - 202) 1ℓ

## 4. COMPONENTS NAME

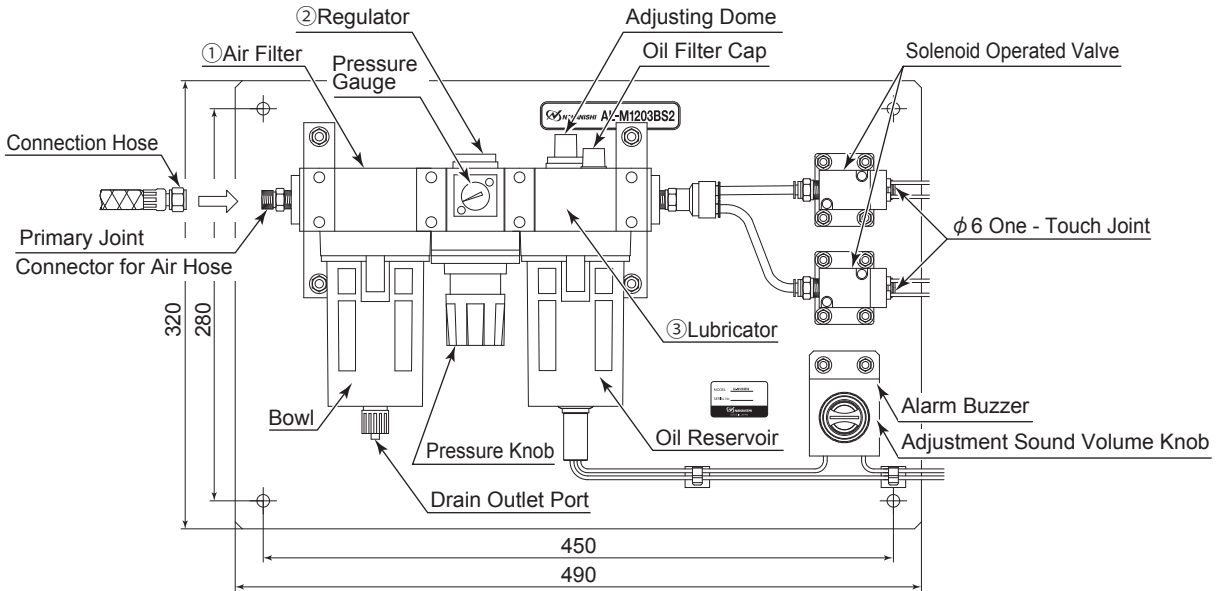

Fig. 1

If the Air Filter, Regulator or Lubricator are damaged, all components are replacable by the end-user (Refer to Table 1 and Table 2.).

Table 1.

	Name	Model	Manufacturer
①	Air Filtar	F4000 - 8 - W - FY	CKD
②	Regulator	R3000 - 8 - W	
③	Lubricator	L4000 - 8 - W - LL	

Table 2. Air Filter Lubricator Replacing Option.

Name	Model	Manufacturer
Air Filter Bowl Assy ( Aoto Drain Polycarbonate Bowl with Manual Cock.)	F4000 - W - BOWL - F	CKD
Air Filter Consumable Parts Kit (The set includes the Louver, Baffle, Element and Bowl O - Ring.)	F4000 - KIT - Y	
Lubricator Bowl Assy (This set includes the Bowl Assy and Bowl O - Ring.)	L4000 - BOWL - LL	

## 5. OPERATION

### 5 - 1 Air Filter (Fig. 2)

The water, dirt and debris are separated from the compressed air.

The separated debris is collected in the Bowl.

### 5 - 2 Automatic Drain Mechanism (Fig. 2)

If debris has accumulated to the upper limit of the bowl, or if air pressure is not applied to the bowl, the bowl will discharge from the Drain Outlet Port by the "Auto Drain Mechanism."

Connect a drain hose with a  $\phi 6\text{mm}$  I.D. (Not included/ provided by the end-user) to the Drain Out Port to discharge the debris.

< To manually drain the bowl >

Allows manual draining of the bowl before debris accumulates to upper limit.

Opening and closing the drain valve.

O direction : Draining.

S direction : Stop Draining.

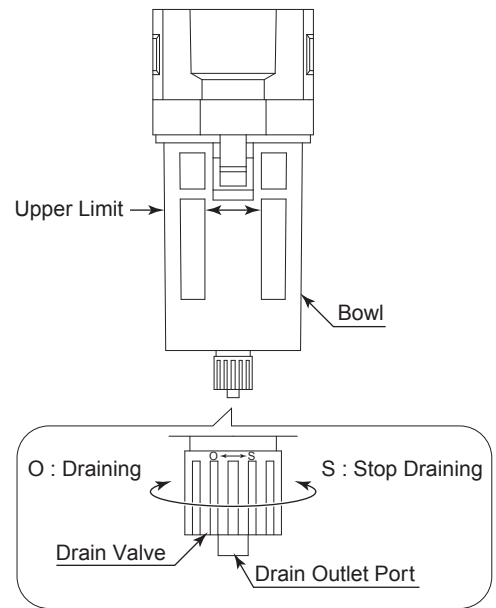

Fig. 2

### 5 - 3 Regulator (Fig. 3)

< Lock and Release of the Regulator Knob >

Regulator Knob is equipped with Lock mechanism.

Release : Pull the Regulator Knob OUT to unlock.

Lock : Push the Regulator Knob IN to the Lock position.

< Adjusting Air Pressure >

Turn the Regulator Knob while watching Pressure Gauge increase or decrease.

H direction : Air pressure is increased.

L direction : Air pressure is decreased.

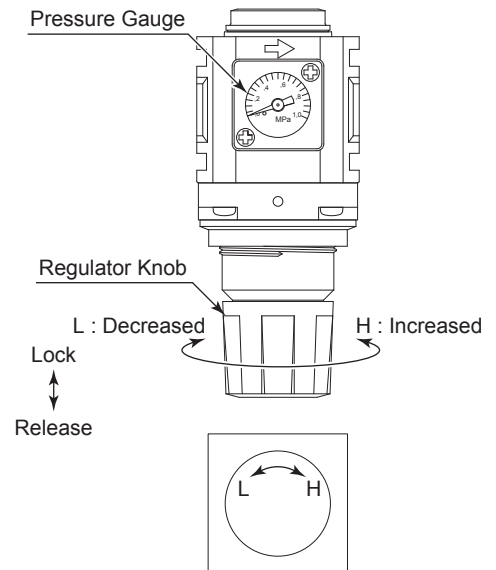

Fig. 3

## 5 - 4 Lubricator

### ⚠ CAUTION

- Make sure to turn the compressed air supply to the Air Line Kit is OFF, before replacing the Lubricating Oil or draining the water in Lubricating Oil.
- Check the Lubricating Oil level everyday and before use. If Lubricating Oil level is low, Fill the oil bowl with Lubricating Oil up to the Upper Oil Limit on the bowl.
- If collected water in the lubricator taints Lubricating Oil, replace the Lubricating Oil immediately.

#### (1) Oil Amount (Fig. 4)

Check the Oil Amount in the Window.

If the Lubricating Oil level is low, add additional oil.

(Supply Lubricating Oil to Upper Oil Level Limit of Fig. 4.)

#### (2) Replacing the Lubricating Oil and draining the water in the Lubricating Oil (Fig. 4)

Remove the Oil Reservoir from lubricator drain the water in Lubricating Oil and supply the lubricating oil.

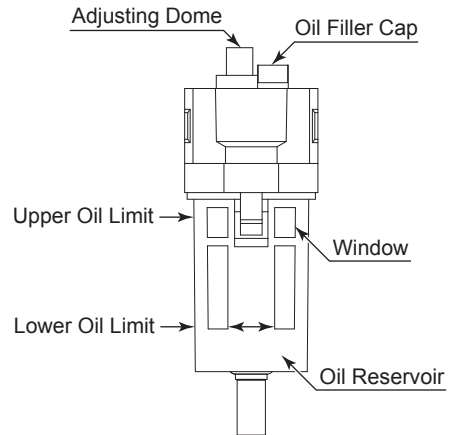

Fig. 4

#### (3) Adjustment of Oil Drip Rate (Fig. 5)

① Set the air pressure to the air motors recommended maximum air pressure.

② Adjust the Oil Drip Rate to the recommended volume which is Table 3.

(If using the Air Turbine Spindle, adjust the Oil Drip Rate to the recommended volume which is 1 drops / min.)

O direction : Increase.

S direction : Decrease.

Table 3.

Number of Air Tool in Use	Oil Drip Rate
One (1) Motor	1 to 3 drops / min.
Two (2) Motors	2 to 6 drops / min.

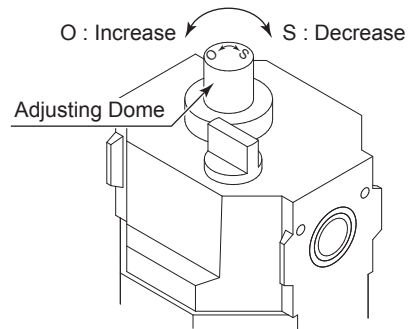

Fig. 5

## 5 - 5 Solenoid Operated Valve

### ⚠ CAUTION

The allowable voltage fluctuation range is  $\pm 10\%$  of the rated voltage (DC+24V).

- Equipped with " 2 port directional operated Solenoid Operated Valves (When applying current, the Solenoid Operated Valve is a Normally Opened Type) ".
- Activate by applying the DC+24V power source voltage to the Solenoid Operated Valve.

## 5 - 6 Alarm Buzzer

If the Lubricating Oil level of the Oil Reservoir is low, the Alarm Buzzer will " Beep ". Adjust the sound volume by turning the Adjustment Sound Volume Knob if needed.

## 6. INSTALLATION AND CONNECTION OF THE AIR LINE KIT

### ⚠ CAUTION

The Air Line Kit must be install horizontally on a vertical surface.

#### 6 - 1 Installation of the Air Line Kit

Mount it to the vertical wall on horizontal attitude. Because the head of the mounting screw is sticking out from the Base Plate, Use the Hexagon Socket Bolts and Spacers (Standard Accessories : 4pcs. Each) when mounting.

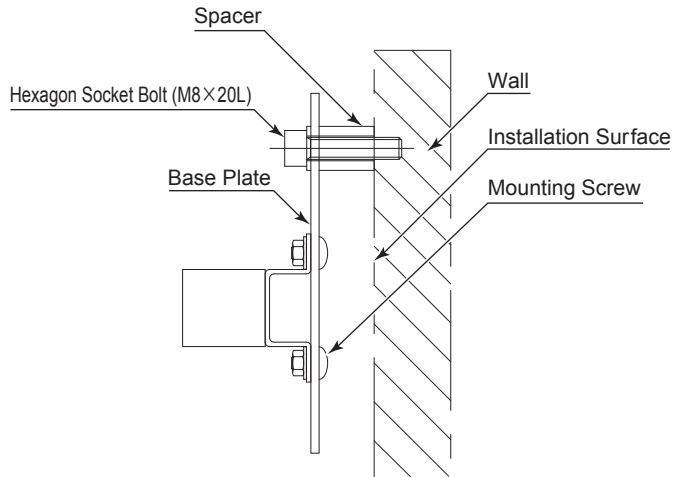

Fig. 6

#### 6 - 2 Connection of the Air Line Kit

- (1) Connect the Connection Hose (Standard Accessory) to the Primary Joint of the Air Line Kit.
- (2) Connect the Filter Joint of the air motor to the  $\phi 6$  One - Touch Joint of the Secondary Joint of the Air Line Kit.
- (3) Connect the DC+24V power source voltage to the electric wire of the Solenoid Operated Valve and Alarm Buzzer.

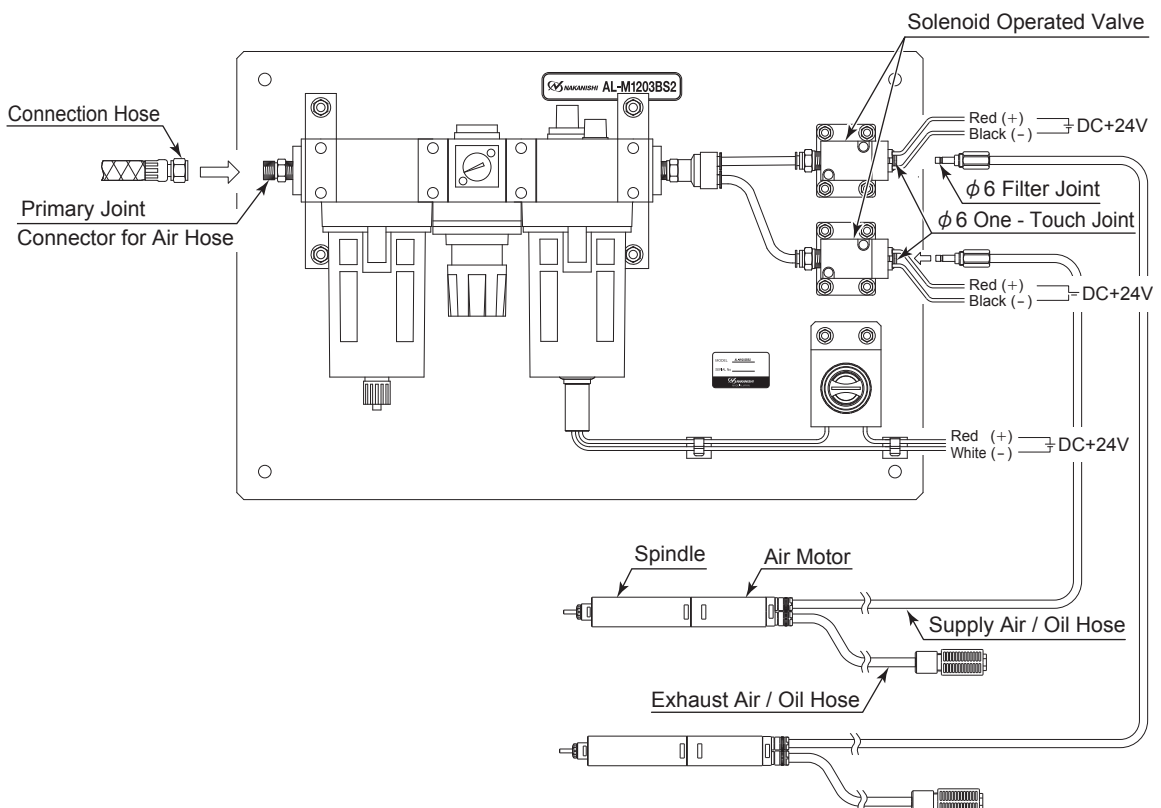

Fig. 7



## 7. TROUBLESHOOTING

If a problem or concern occur, please check the following items prior to consulting your dealer.

Trouble	Inspection / Corrective Active
Broken connection hose and supply air / oil hose.	Replace the connection hose and supply air / oil hose.
No air flow.	Check the compressor power supply and the air compressor output.
	Check if connection hose and supply air / oil hose are broken, bent or disconnected.
	Check the Regulator and set to the correct air pressure. Check all connection hose and supply air / oil hose connections.
Air leakage.	Check all threaded joints and re-tighten if necessary.
Low air pressure.	Check the Compressor, Air Circuit, and Regulator.
Low Lubricating Oil or no Lubricating Oil.	Check lubricator for proper lubricant level. Set the Oil Drip Rate from 1 to 3 drops /min. Removing the supply air / oil hose from the $\phi 6$ One - Touch joint of the Solenoid Operated Valve, supply a small amount of oil directly into the supply air / oil hose if bowl is completely empty.
Excessive oil drips.	An excessive amount of oil drips into the system will cause the bearings to flood, slowing the speed or causing the air motor / spindle speed to fluctuate. Drain the Lubricating Oil in the bowl to the proper level by loosening Drain Valve. Use the Adjusting Dome to adjust the Oil Drip Rate. (Recommended Volume : Vane Type Motor : Refer to " 5 - 4 Lubricator (3) Table 3 ". (Air Turbine Spindle : 1 drop / min.).
Insufficient number of oil drops.	Air Tool and Reducer internal components will be deprived of oil and the longevity will be dramatically shortened. Set the Oil Drip Rate (Refer to " 5 - 4 Lubricator (3) Table 3 ").
Water in Lubricating Oil Reservoir.	Drain water from Lubricating Oil reservoir and replace with clean Lubricating Oil.
Water, dirt and debris are collected in the Air Filter.	Drain water, dirt and debris from the Air Filter bowl.
Even if drain reaches to the upper limit of the bowl, drain is not drained.	Automatic Drain Mechanism is broken. Replace the Air Filter Bowl Assy. as refer to in Section 4 / Table 2 " Air Filter Bowl Assy (Model : F4000 - W - BOWL - F) ".

## 8. DISPOSAL OF THE AIR LINE KIT

When disposal of an Air Line Kit is necessary, follow the instructions from your local government agency for proper disposal of industrial components.

株式会社ナカニシ  
〒322-8666  
栃木県鹿沼市下日向700  
TEL: 0289-64-3380  
FAX: 0289-62-5636  
www.nakanishi-inc.com

NAKANISHI INC.   
700 Shimohinata, Kanuma  
Tochigi 322-8666  
Japan  
www.nakanishi-inc.com

NSK America Corp.  
1800 Global Parkway  
Hoffman Estates  
IL 60192, USA  
www.nskamericacorp.com

NSK Europe GmbH   
Elly-Beinhorn-Strasse 8  
65760 Eschborn  
Germany

NSK United Kingdom Ltd.  
UK Responsible Person  
Office 4, Gateway 1000  
Arlington Business Park, Whittle Way  
Stevenage, SG1 2FP, UK