



モータスピンドル / Motor Spindle

EMSF - 3060K - RBT

取扱説明書 / OPERATION MANUAL

日本語 : P1 - P8 / English : P9 - P16



OM-KK0902JA 002

Thank you for purchasing the Motor Spindle " EMSF-3060K-RBT ". This Motor Spindle is designed for grinding, small diameter drilling and milling, etc. The E3000 CONTROLLER and Air Line Kit are required to drive this Motor Spindle.

Read this and all the associated component Operation Manuals carefully before use. Always keep this Operation Manual in a place where a user can referred to for reference at any time.

1. CAUTIONS FOR HANDLING AND OPERATION

- Read these warnings and cautions carefully and only use in the manner intended.
- These warnings and cautions are intended to avoid potential hazards that could result in personal injury to the operator or damage to the device. These are classified as follows in accordance with the seriousness of the risk.

Class	Degree of Risk
 WARNING	A safety hazard could result in bodily injury or damage to the device if the safety instructions are not properly followed.
 CAUTION	A hazard that could result in light or moderate bodily injury or damage to the device if the safety instructions are not followed.

WARNING

- ① This Motor Spindle is not a hand tool. It is designed to be used on CNC machines or special purpose machines.
- ② Do not touch the cutting tool while it is running. It is very dangerous.
- ③ Wear safety glasses, dust mask, and use a protective cover around the Spindle whenever the Spindle is rotating.
- ④ Never connect, disconnect or touch the Power Cord Plug or Motor Cord Plug with wet hands. This may cause an electric shock.
- ⑤ Never operate or handle the Motor Spindle until you have thoroughly read the Operation Manuals and safe operation has been confirmed.
 - 1) To prevent injuries / damages, check the Motor Spindle and cutting tool for proper installation, before operating the Motor Spindle.
 - 2) Before disconnecting the Motor Spindle, always turn the control power off and turn the compressed air supply to the CONTROLLER off. Then it is safe to remove the Motor Spindle.
- ⑥ Whenever installing a Motor Spindle to a fixed metal base, ensure that the fixed metal base is grounded in order to avoid risk of an electric shock.
- ⑦ When installing a tool, tighten the collet correctly and check again the collet and collet nut before use. Do not over-tighten the collet. This may cause damage to the spindle.
- ⑧ Do not use bent, broken, chipped, out of round or sub-standard tools, as this may cause them to shatter or explode. Tools with fractures or a bent shank will cause injury to the operator. When using a new tool, rotate it in a low speed and increase speed gradually for safety.
- ⑨ Do not exceed the recommended maximum allowable speed of the tool. For your safety, use speeds below the maximum allowable speed.
- ⑩ Do not apply excessive force. This may cause injury to the operator by slippage or damage of the tool, or loss of concentricity and precision of the Motor Spindle.

⚠ CAUTION

- ① Do not drop or hit this Motor Spindle, as shock can damage to the internal components.
- ② Be sure to clean the collet and collet nut, the inside of the spindle before replacing the tool (cutting tool). If ground particles or metal chips stick to the inside of spindle or the collet, damage to the collet or spindle can occur due to the loss of precision.
- ③ When cleaning a Motor Spindle, stop the Motor Spindle and remove debris with a soft brush or a cloth. Do not blow air into the dust proof cover area (refer to section " 6 - 2 Outside View ") with compressed air as foreign particles or cutting debris may get into the ball bearing.
- ④ Always clean the tool shank before installing the tool in the Motor Spindle.
- ⑤ When sizing the correct collet size to the tool shank diameter, a tolerance of $+0 \sim - 0.01\text{mm}$ is strongly recommended. A tool shank within the $+0 \sim - 0.1\text{mm}$ range is mountable, however, this may cause poor concentricity and or insufficient tool shank gripping force.
- ⑥ Select suitable products or tools for all applications. Do not exceed the capabilities of the Motor Spindle or tools.
- ⑦ Do not stop the supply cooling air for motor during operation of the machine. Removing the air pressure from the Motor Spindle causes a loss of purging, allowing the Motor Spindle to ingest coolant. This will cause damage to the Motor Spindle.
- ⑧ Carefully direct coolant spray directly on the tool. Do not spray directly on the Motor Spindle and collet nut. Large amounts of coolant sprayed directly on the Motor Spindle may cause excess load of the Motor Spindle causing a loss of durability and longevity of the Motor Spindle.
- ⑨ Stop working immediately when abnormal rotation or unusual vibration are observed. Immediately, please check the content of section " 13. TROUBLESHOOTING ".
- ⑩ Always check if the tool, collet, collet nut, connection hose and supply air hose for damaged before and after operating.
- ⑪ If the collet or collet nut show signs of wear or damage, replace them before a malfunction or additional damage occurs.
- ⑫ After installation, repair, initial operation, or long periods of non operation, please refer to section " 11. BREAK-IN PROCEDURE " detailed in Table 2. When checking the Motor Spindle, no vibration or unusual sound should be observed during rotation.
- ⑬ Do not disassemble, modify or attempt to repair this Motor Spindle. Additional damage will occur to the internal components. Service must be performed by NSK NAKANISHI or an authorized service center.
- ⑭ When using this Motor Spindle for mass production, please consider the purchase of an additional Motor Spindle to be used as a back-up in case of emergency.
- ⑮ Securely connect the compressor supply connection hose and the air hose to the Air Line Kit and the Motor Spindle to avoid accidental disconnection during use.



2. BASIC PACKAGE

When opening the package, check if it includes all items listed in " Table.1 Packing List Contents ".

In the event of any shortage, please contact either NAKANISHI (see the " 4. CONTACT US " section) or your local dealer.

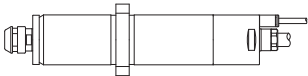
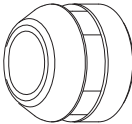
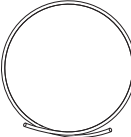
Table 1. Packing List Contents

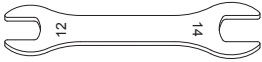
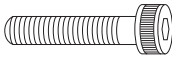
<p>Motor Spindle • • 1pc.</p>  <p>EMS F - 3060K - RBT</p>	<p>Collet Nut (K - 265) • • 1pc.*</p> 	<p>Air Hose • • 1pc.* EMS F - 3060K - RBT : 0.3m</p> 
--	---	--

<p>Wrench (12 × 14) • • 2pcs.</p> 	<p>Hexagon Socket Head Screw (M4 x 16) • • 4pcs.</p> 	<p>Inspection Card • • 1pc.</p> 	<p>Operation Manual • • 1set</p> 
--	--	---	--

* The collet nut and Air Hose are attached to the Motor Spindle.

3. WARRANTY

We provide a limited warranty for our products. We will repair or replace the products if the cause of failure is due to the following manufactures defects. Please contact us or your local distributor for details.

- (1) Defect in manufacturing.
- (2) Any shortage of components in the package.
- (3) Where damaged components are found when initially opening the package.
(This shall not apply if the damage was caused by the negligence of a customer.)

4. CONTACT US

For your safety and convenience when purchasing our products, we welcome your questions. If you have any questions about operation, maintenance and repair of the product, please contact us.

Contact Us

● For U.S. Market

Company Name : **NSK America Corp.**
Industrial Div.
Business Hours : 8:00 to 17:00 (CST)
(closed Saturday, Sunday and Public Holidays)
U.S. Toll Free No. : +1 800 585 4675
Telephone No. : +1 847 843 7664
Fax No. : +1 847 843 7622
Website : www.nskamericacorp.com

● For Other Markets

Company Name : **NAKANISHI INC.** 
Business Hours : 8:00 to 17:00 (JST)
(closed Saturday, Sunday and Public Holidays)
Telephone No. : +81 289 64 3520
e-mail : webmaster-ie@nsk-nakanishi.co.jp

5. FEATURES

- ① The Motor Spindle housing is made from precision ground, hardened, stainless steel (SUS) with an outside diameter of ϕ 30mm.
- ② Excellent durability and high reliability are obtained by using a high-speed brushless motor, which eliminates the need for brush replacement and frequent maintenance.
- ③ A quick disconnect cord is available for easy brushless motor removal.
- ④ Various sizes of collets are available CHK 0.5mm - 6.35mm. Standard collet is CHK 3.0mm or CHK 3.175mm.
(For U.S. market CHK 3.175mm.)

6. SPECIFICATIONS AND DIMENSIONS

6 - 1 Specifications

Model	EMSF-3060K-RBT
Maximum Motor Rotation Speed	60,000min ⁻¹ (rpm)
Spindle Accuracy	Less than 1μm
Max. Output	350W
Weight	600g
Noise Level at 1m distance	Less than 65dB
IP Code	IP57 (When air is supplied.)

	Temperature	Humidity	Atmospheric Pressure
Operation Environment	0 - 40°C	MAX.75% (No condensation)	800 - 1,060hPa
Transportation and Storage Environment	-10 - 50°C	10 - 85%	500 - 1,060hPa

<Options>

Motor Cord *Note 1	3m, 4(3.7)m, 6(5.7)m, 8(7.7)m (The Air Hose (φ 4.0mm) of the same length is attached.)
Collet (CHK - □□) *Note 2	φ 0.5mm - φ 6.0mm in 0.1mm increments and φ 2.35mm, φ 3.175mm, φ 6.35mm

*Note 1 : Motor Cord is sold separately.

Please select the suitable motor cord length for your application.

*Note 2 : Collet is sold separately. Please select the suitable collet size for your application.

6 - 2 Outside View

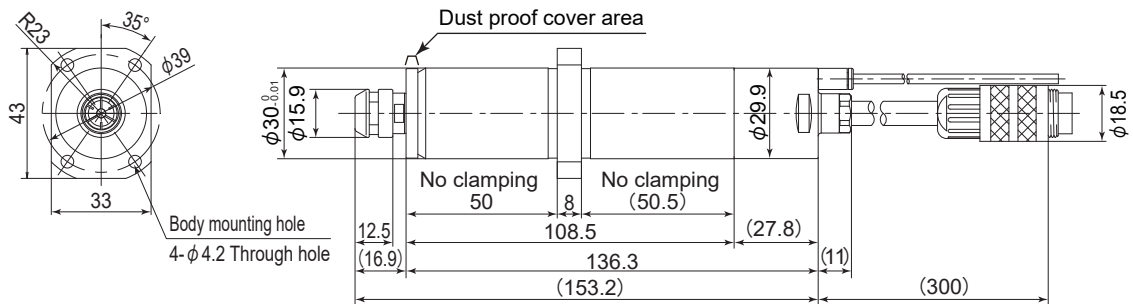

Fig. 1

6 - 3 Torque Characteristics

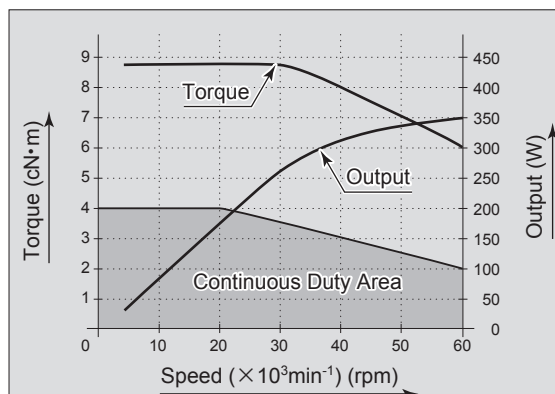

Fig. 2

7. CHANGING THE TOOL

⚠ CAUTION

Do not tighten the collet without inserting the test bur or the tool shank into the collet, as this will damage the collet, spindle or collet nut, causing difficulty removing the collet.

RECOMMENDATION

Please set the cutting tools to minimize the overhang amount. 13mm is the maximum amount of overhang to maintain high accuracy and safety.

- ① Set the provided 12mm wrench on the spindle shaft.
- ② Place the provided 14mm wrench on the collet nut and turn it counterclockwise to loosen the collet and remove the tool. (The first turn will loosen the collet nut, but the tool will not release and turning will become stiff. Keep turning through the stiffness and the collet will open.)
- ③ Clean the collet and collet nut, then insert the new tool and tighten the collet by turning clockwise. Do not overtighten.

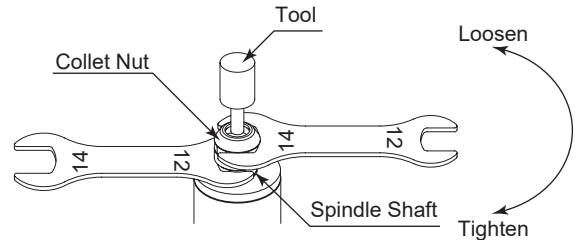

Fig. 3

8. REPLACING THE COLLET

⚠ CAUTION

When installing the collet into the collet nut, be sure to fully engage the latch inside the collet nut to the groove on the collets outer diameter area. In addition, remember that if the collet is attached without being engaged with the latch of the collet nut, the collet cannot be removed and this may cause damage to the collet or the spindle.

- ① Remove the tool according to the section "7. CHANGING THE TOOL" procedure above and remove collet nut assembly (Fig. 4).
- ② The collet and collet nut are secured by a groove in the collet and a flange in the collet nut. To remove the collet hold the collet nut in one hand and push diagonally down on the collet. The collet should be released (Fig. 5).
- ③ To install the collet, hold the collet at a slight angle, and insert it into the collet nut (Fig. 6). Press the collet in the collet nut by positioning the collet in the collet nut and pressing down on flat surface (Fig. 5). Be sure to fully engage the latch inside the collet nut into the groove on the collets outer circumference area (Fig. 7).

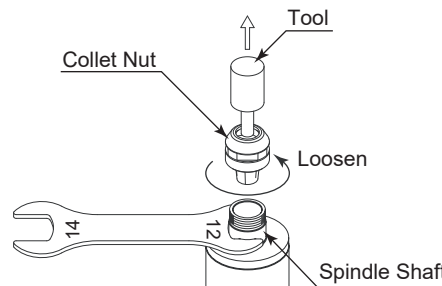

Fig. 4

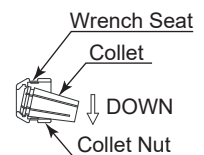

Fig. 5

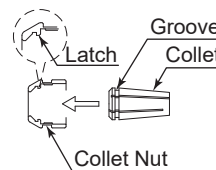

Fig. 6

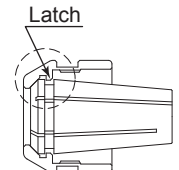

Fig. 7

9. CONNECTION OF MOTOR CORD

⚠ CAUTION

- Before connecting to the Motor Cord to the Motor and CONTROLLER, verify the Main Power Switch on the CONTROLLER is turned OFF. If the Main Power Switch on the CONTROLLER is ON while connecting the Motor Cord, damage to the CONTROLLER is possible.
- Install the protective cover (Protective Cover etc.) to prevent damage or contamination to the Motor Cord Plug when not in use.

- ① Remove the Protective Cover of the Motor Cord Plug and keep it for use when not using the Motor / Spindle to keep the connector pins safe and clean.

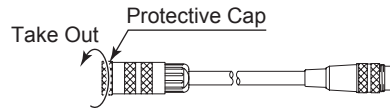

Fig. 8

- ② Carefully insert the Alignment Pin on the Motor Spindle Cord Connector into the Alignment Hole on the Motor Cord Connector, then push straight into the Motor Cord.

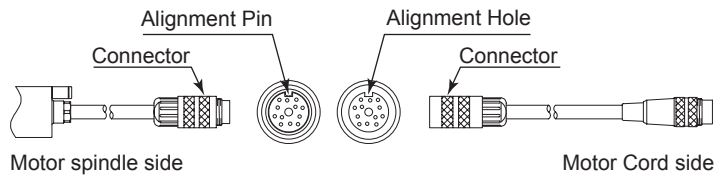

Fig. 9

- ③ Tighten the Connector Nut of the Motor Cord in a clockwise direction.

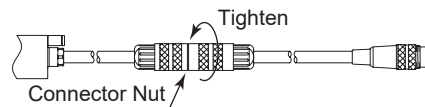

Fig. 10

- ④ Remove the protective air plug.

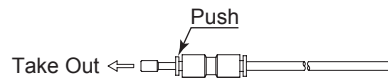

Fig. 11

- ⑤ Insert the provided air hose.

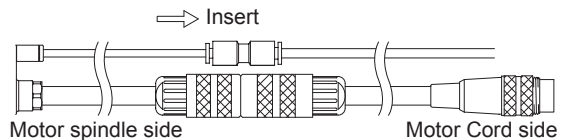

Fig. 12

10. INSTALLATION OF THE MOTOR SPINDLE

⚠ WARNING

When installing a Motor Spindle to a fixed base, make sure the fixed base is grounded in order to avoid the risk of an electric shock.

⚠ CAUTION

Do not allow set screws and the slit to come directly in contact with the Motor Spindle body as shown in Fig. 14, as this will result in damage to the Motor Spindle housing and internal components. Do not hit, drop or cause shock to the Motor Spindle when installing.

This flange designed to eliminate deformation / damage of the Motor Spindle when performing the installation. When install a Motor Spindle, refer to Fig. 13.

- ① Insert the Motor Spindle housing diameter section into the machines tool plate bore.
- ② Secure the Motor Spindle through the counter-sunk holes (4 locations) on the flange using Hexagon Socket Head Screw (M4 x 16) as shown in Fig. 13.

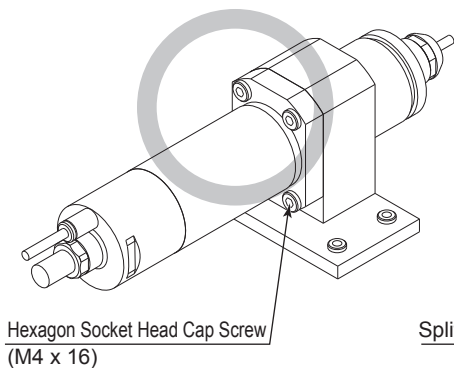

Fig. 13

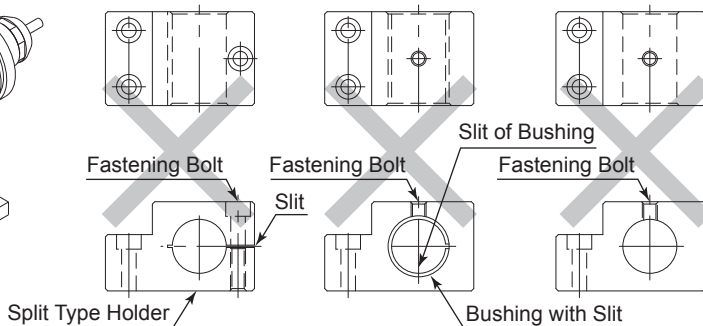

Fig. 14

11. BREAK-IN PROCEDURE

During transportation, storage or installation, the grease inside the bearings will settle. If the Motor Spindle is suddenly run at high-speed, the grease will be ejected from the bearings, causing excessive heat that will cause bearing damage.

After installation, repair, initial operation, or long periods of non operation, please follow the break-in procedure detailed in Table 2.

Table 2.

Steps	1	2	3	4	5
Rotation Speed (min ⁻¹) (rpm)	15,000	30,000	40,000	50,000	60,000
Rotation Time (min)	15	10	10	10	10
Items to Check	No Abnormal Noises.	The Motor Spindle housing temperature during the break-in process should not exceed 20 degrees C (36 degrees F) above ambient temperature. Should the Motor Spindle exceed this limit, rest the motor spindle for at least 20 minutes and re-start the break in procedure from the beginning. If the housing temperature rises again and exceeds 20 degrees C (36 degrees F) above ambient temperature, check the Motor Spindle for proper installation.			The Motor Spindle housing temperature during the break-in process should not exceed 25 degrees C (45 degrees F) above ambient temperature.

12. CAUTIONS WHEN USING GRINDSTONES AND TOOLS

⚠ CAUTION

The maximum surface speed or rpm is always specified for a grindstone. Do not exceed the maximum speed with reference to the calculating chart below. Always follow the grindstone manufacturer's recommendations.

$$\text{Surface Speed (m/s)} = \frac{3.14 \times \text{Diameter (mm)} \times \text{rotation speed (min}^{-1}\text{) (rpm)}}{1,000 \times 60}$$

- ① The proper surface speed for general grindstones is 10-30m / s.
- ② Do not exceed 13mm of overhang for mounted grindstones as shown in Fig. 15. If the overhang must exceed 13mm, reduce the brushless motor speed in accordance with Table 3.
- ③ Dress the grindstone prior to use.
- ④ Do not use cutting tools with bent or broken shanks, cracks or excessive run-out.
- ⑤ For grinding, the maximum depth of cut should not exceed 0.01mm radially or axially. Reciprocate the tool several times after each pass to eliminate tool pressure.
- ⑥ Always operate cutting tools within the allowable recommended speed of the cutting tools. Use of a cutting tool outside of the allowable speed of the cutting tools could cause damage to the Spindle and injury to the operator.

- ⑦ Keep the cutting tool shank and collet clean. If contaminants are left in the collet or collet nut, excessive run-out will cause damage to the cutting tool and or Spindle.
- ⑧ Do not strike or disassemble the Motor Spindle.
- ⑨ Please set the cutting tools to minimize the overhang amount. 13mm is the maximum amount of overhang to maintain high accuracy and safety.

Table 3. Overhang and Speed

Overhang (mm)	Max. Speed (min ⁻¹) (rpm)
20	N x 0.5
25	N x 0.3
50	N x 0.1

※ N = Max. Operating Speed with 13mm overhang.

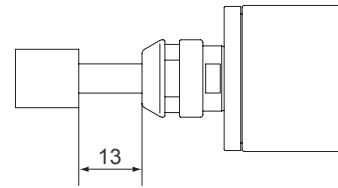

Fig. 15

13. TROUBLESHOOTING

If a problem or concern occur, please check the following items prior to consulting your dealer.

Trouble	Cause	Inspection / Corrective Action
Motor Spindle does not rotate or rotate smoothly.	The spindles ball bearings have been damaged.	Replace the ball bearings. (Return to NAKANISHI dealer service.)
	The motor has been damaged.	Replace the motor. (Return to NAKANISHI dealer service.)
Overheating during rotation.	Cutting debris has contaminated the ball bearings, and the ball bearings are damaged.	Replace the ball bearings. (Return to NAKANISHI dealer service.)
	Low air pressure.	Check air hose connection and air pressure.
Abnormal vibration or noise during rotation.	The tool shank is bent.	Replace the tool.
	Cutting debris has contaminated the ball bearing.	Replace the ball bearings. (Return to NAKANISHI dealer service.)
	The spindles ball bearings have been damaged.	
Tool slippage.	Collet or collet nut are not correctly installed.	Check and clean the collet and collet nut. Reinstall the collet and collet nut.
	The collet and the collet nut are worn.	Replace the collet and collet nut.
High run-out.	The tool is bent.	Change the tool.
	Collet nut is not correctly installed.	Secure the collet and the collet nut correctly.
	The collet and the collet nut are worn.	Replace the collet and the collet nut.
	Inside of the spindle is worn.	Replace the spindle shaft. (Return to NAKANISHI dealer service.)
	Contaminants inside the collet and the collet nut or the spindle.	Clean the collet, collet nut and the inside of the taper and spindle.
	The spindle ball bearings has been damaged.	Replace the ball bearings. (Return to NAKANISHI dealer service.)

Refer to the E3000 CONTROLLER Operation Manual.

14. DISPOSAL OF THE MOTOR SPINDLE

When disposal of a Motor Spindle is necessary, follow the instructions from your local government agency for proper disposal of industrial components.

株式会社ナカニシ
〒322-8666
栃木県鹿沼市下日向700
TEL: 0289-64-3380
FAX: 0289-62-5636
www.nakanishi-inc.com

NAKANISHI INC. 
700 Shimohinata, Kanuma
Tochigi 322-8666
Japan
www.nakanishi-inc.com

NSK America Corp.
1800 GlobalParkway
Hoffman Estates
IL 60192, USA
www.nskamericacorp.com

NSK Europe GmbH 
Elly-Beinhorn-Strasse 8
65760 Eschborn
Germany

NSK United Kingdom Ltd.
UK Responsible Person
Office 4, Gateway 1000
Arlington Business Park, Whittle Way
Stevenage, SG1 2FP, UK