

# NE260

**OPERATION MANUAL**

OM-K0581E



※Specifications may be changed without notice.

**NAKANISHI INC.**   
[www.nakanishi-inc.com](http://www.nakanishi-inc.com)700 Shimohinata Kanuma-shi  
Tochigi 322-8666,  
Japan**NSK Europe GmbH**   
[www.nsk-europe.de](http://www.nsk-europe.de)Elly-Beinhorn-Strasse 8  
65760 Eschborn,  
Germany**NSK America Corp**  
[www.nskamericacorp.com](http://www.nskamericacorp.com)1800 Global Parkway  
Hoffman Estates, IL 60192,  
USA'09.05.003 

## CONTENTS

IMPORTANT INSTRUCTIONS AND WARNING-Electric Devices .....P.1	<b>11</b> AIR HOSE CONNECTION.....P.17
<b>1</b> CAUTIONS FOR HANDLING AND OPERATION .....P.3	<b>12</b> CHANGING CUTTING TOOLS.....P.18
<b>2</b> FEATURES.....P.5	<b>13</b> REPLACING THE COLLET .....P.19
<b>3</b> SPECIFICATIONS.....P.6	<b>14</b> FIXTURING THE MOTOR/SPINDLE.....P.19
<b>4</b> SYSTEM CHART .....P.8	<b>15</b> OPERATION PROCEDURES .....P.21
<b>5</b> TORQUE CHARACTERISTICS .....P.10	<b>16</b> EXTERNAL INPUT/OUTPUT CONTROL SIGNAL SPECIFICATIONS.....P.23
<b>6</b> NOMENCLATURE .....P.11	<b>17</b> PROTECT FUNCTION.....P.31
<b>7</b> CHANGING FUSES.....P.13	<b>18</b> BREAK-IN PROCEDURE .....P.33
<b>8</b> BRACKET INSTALLATION .....P.14	<b>19</b> CUTTING TOOL CAUTIONS.....P.34
<b>9</b> POWER CORD CONNECTION .....P.16	<b>20</b> TROUBLE SHOOTING .....P.35
<b>10</b> MOTOR CORD CONNECTION .....P.16	<b>21</b> SETTING OF OPERATING PARAMETERS.....P.35

## IMPORTANT INSTRUCTIONS AND WARNING - Electric Devices

### WARNING !

When using electric tools, basic safety precautions should always be followed to reduce the risk of fire, electrical shock and personal injury, including the following.

Read all these instructions before operating this product and save these instructions.

#### A. GROUNDING INSTRUCTIONS

- In the event of a malfunction or breakdown, grounding provides a path of least resistance for electric current to reduce the risk of electric shock. This tool is equipped with an electric cord with a grounding conductor and a grounding plug. The plug must be plugged into a matching outlet that is properly installed and grounded in accordance with all local codes and ordinances.
- Do not modify the plug provided - if it will not fit the outlet, have the proper outlet installed by a qualified electrician.
- Improper connection of the grounding conductor can result in electric shock. The conductor with insulation having an outer surface that is green with or without yellow stripes is the grounding conductor. If repair or replacement of the electric cord or plug is necessary, do not connect the grounding conductor to a live terminal.
- Check with a qualified electrician or service person if the grounding instructions are not completely understood, or if in doubt as to whether the tool is properly grounded.
- Use only 3-wire extension cords that have 3-prong grounding plugs and 3-pole receptacles that accept the tool's plug.
- Repair or replace damaged or worn cord immediately.
- This tool must be used on a circuit that has an outlet that looks like the one illustrated in Sketch A in Figure (below) (115V). The tool has a grounding plug that looks like the plug illustrated in Sketch A in Figure (below).
- FOR Installation in Machine Electrical Cabinet or when wiring directly to machine internal power terminal strip:
  - Please refer to the pin diagram below for the proper wiring configuration. The plug shown is the female plug that attaches to the NE260 main power inlet.
  - Make sure you test each individual wire to verify proper circuit prior to attaching any wire to the terminal block. Do not assume wire colors are the same for all power cords.
- Install an over current protective device of maximum 10 Amp on the NE260 main power circuit.

#### Grounding Method

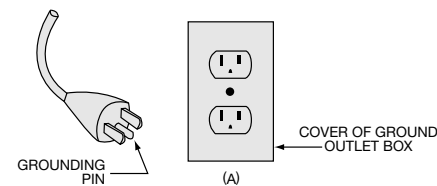

- USE PROPER EXTENSION CORD. Make sure your extension cord is in good condition. When using an extension cord, be sure to use one heavy enough to carry the current your product will draw. An undersized cord will cause a drop the line voltage resulting in loss of power and overheating. Table (below) shows the correct size to use depending on cord length and nameplate ampere rating. If in doubt, use the next heavier gage. The smaller the gage number, the heavier the cord.

#### Power cord connector

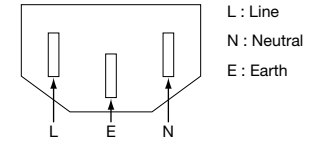

#### Minimum gage for cord

Ampere Rating	Volts	Total length of cord				
		7.5m (25ft.) 15m (50ft.)	15m (50ft.) 30m (100ft.)	30m (100ft.) 60m (200ft.)	45m (150ft.) 90m (300ft.)	
More Than	Not More Than					
0	6	18	16	16	14	
6	10	18	16	14	12	
10	12	16	16	14	12	
12	16	14	12	Not Recommended		

Only the applicable parts of the Table need to be included. For instance, a 120-volt product need include the 240-volt heading.

#### B. OTHER WARNING INSTRUCTIONS



- For your own safety read instruction manual before operating tool.
- Wear eye protection.
- Replace cracked wheel immediately.
- Always use guards and eye shields.
- Do not overtighten wheel nut.
- Use only flanges furnished with the grinder.
- REMOVE ADJUSTING KEYS AND WRENCHES. Get in the habit of checking to see that keys and adjusting wrenches are removed from tool before turning it on.
- KEEP WORK AREA CLEAN. Cluttered areas and benches invite accidents.
- DON'T USE IN DANGEROUS ENVIRONMENT. Don't use power tools in damp or wet locations, or expose them to rain. Keep work area well lighted.
- Risk of injury due accidental starting. Do not use in an area where children may be present.
- DON'T FORCE TOOL. It will do the job better and safer at the rate for which it was designed.
- USE RIGHT TOOL. Don't force tool or attachment to do a job for which it was not designed.
- WEAR PROPER APPAREL. Do not wear loose clothing, gloves, neckties, rings, bracelets, or other jewelry that might get caught in moving parts. Nonslip footwear is recommended. Wear protective hair covering to contain long hair.
- ALWAYS USE SAFETY GLASSES. Everyday eyeglasses only have impact resistant lenses, they are NOT safety glasses. Also use face or dust mask if cutting operation is dusty.
- SECURE WORK. Use clamps or a vise to hold work when practical. It's safer than using your hand and it frees both hands to operate tool.
- MAINTAIN TOOLS WITH CARE. Keep tools sharp and clean for best performance and to reduce the risk of injury to persons. Follow instructions for lubricating and changing accessories.
- DISCONNECT TOOLS before servicing; when changing accessories, such as blades, bits, cutters, and like.
- REDUCE THE RISK OR UNINTENTIONAL STARTING. Make sure switch is in off position before plugging in.
- USE RECOMMENDED ACCESSORIES. Consult the owner's manual for recommended accessories. The use of improper accessories may cause risk of injury to persons.
- NEVER LEAVE TOOL RUNNING UNATTENDED. TURN POWER OFF. Don't leave tool until it comes to a complete stop.
- For recommended operating speed for various applications, please follow the instructions of bur manufacturers.

Thank you for purchasing the Ultra-Precision, High-Speed spindle system, E3200. The E3200 system was designed for use on CNC lathes, robots, NC lathes and special purpose machines. The motor, spindle and control unit are designed to work as an integrated system capable of 80,000 min<sup>-1</sup>. This system utilizes air to cool the motor and protect the spindle, please use an air line kit to ensure clean, dry, properly regulated air is supplied to the motor and spindle.

The E3200 system is capable of being used with coolants and cutting lubricants. Please read this Operation Manual carefully prior to use.

## 1 CAUTIONS FOR HANDLING AND OPERATION

- Read these cautions carefully and only use in the manner intended.
- Safety instructions are intended to avoid potential hazards that could result in personal injury or damage to the device. Safety instructions are classified as follows in accordance with the seriousness of the risk.

Class	Degree of Risk
 DANGER	Existence of a hazard that could result in personal death or serious injury, if the safety precautions are not followed.
 WARNING	A hazard that could result in bodily injury or damage to the device if the safety instructions are not followed.
 CAUTION	A hazard that could result in light or moderate bodily injury or damage to the device if the safety instructions are not followed.

### DANGER

Do not rotate the machining center's main spindle with the HES installed. Rotating the machining center's main spindle with the HES installed can cause the motor cord to become tangled and pull the Control Unit off its mounting.

### WARNING

1. The E3200 is not a hand tool. It is designed to be used on a NC lathe or special purpose machine.
2. In the event of a malfunction or breakdown, grounding provides a path of least resistance for electric current, reducing the risk of electric shock. This system is equipped with an electric cord with a grounding conductor and a grounding plug. The plug must be plugged into a matching outlet that is properly installed and grounded in accordance with all local codes and ordinances.
3. Don't use in dangerous environments. Protect the control unit from moisture and other contaminants. Failure to protect the control unit can result in damage to internal components and injury to the operator.
4. Always wear safety glasses. Everyday eyeglasses only have impact resistant lenses, they are not safety glasses. Also use a dust or face mask whenever the motor is running.

5. Never touch the motor, spindle or cutting tools when the spindle is rotating.
6. Reduce the risk of unintentional starting. Make sure the power switch is in the Off position before connecting the control unit or plugging the system in.
7. Do not apply excessive force. This may cause tool slippage or tool damage.
8. Do not exceed the maximum allowable tool speed. For your safety, use tools below the maximum allowable speed.
9. Do not use bent, broken, chipped, out of round or sub-standard tools. They can shatter or explode, and may cause injury.
10. Ensure that the earth wire is properly grounded; failure to follow this warning may result in electric shock or fire.
11. Check to ensure that the supply voltage is the same as the control unit's rated voltage.

### CAUTION

1. Motor cooling and Spindle purge air is required to operate the system. Air hose must be connected to the Air in joint on the front of the control unit. Between 0.25MPa-0.3MPa air must be supplied.
2. Do not disassemble, modify or attempt to repair the unit or motor as it will damage internal components and there are no user serviceable parts.
3. When errors occur and error lamp flashes, check and correct the cause of the malfunction before continuing use. Failure to correct the problem will result in damage to the unit and motor.
4. When the Warning Lamp on the control unit lights conditions exist that could result in dangerous operation. Check operating conditions and continue use only after correcting the problem.
5. Do not hit, drop or subject motor, spindle or control unit to shock as this will cause damage to internal components and result in malfunctions.
6. Check the tool shank and collet prior to use to ensure they are clean and free of burs. The introduction of foreign particles or metal chips into the collet or spindle can cause damage and loss of precision.
7. Make sure that the collet chuck is firmly tightened prior to rotating the spindle. If the collet chuck and chuck nut are not firmly tightened the tool may be ejected during rotation resulting in injury.
8. The electric motor and spindle require air for cooling and protection : ensure that this supply is clean, dry air. Introduction of dust, moisture or other contaminants into the motor and spindle will cause damage to internal components.
9. Do not place anything on top of the control unit or block cooling vents.
10. Do not install system next to RF noise sources as malfunctions can occur. If smoke, noise or strange odors emanate from the unit or motors immediately turn off the power switch, disconnect and take to a NAKANISHI dealer for evaluation.

11. Use only tools with shank diameter tolerance similar to the chuck I.D. tolerance.
12. Check if tools, chucks or chuck nuts are damaged before working.
13. When using NE260 continuously, refer to Continuous Area on Torque Characteristics or check LOAD meter maximum (3 Green Lamps).
14. Attach the provided connector cover when not using Input/Output Connector A/B or Selector Communication Connector.
15. Stop working immediately when abnormal rotations or unusual vibration are observed.
16. Do not over tighten the chuck. This may cause spindle damage.
17. Select suitable products or tools for the applications. Do not exceed the capabilities of the spindles or cutting tools.
18. When using Selector Unit with Control Unit NE260, please use E3200 Series Selector Unit NE261.
19. Please don't touch the heat sink of Control Unit NE260. This may avoid scalding yourself.
20. When using the Air Bearing Spindle, please need to supply the regulated air pressure to the Air Bearing. When rotating the spindle with less the regulated air pressure, this may make you damage to the spindle or the control unit.

## 2 FEATURES

- (1) The E3200 system is designed to be mounted in a CNC lathe, robot, NC lathe or special purpose machine for drilling, milling, slitting, grinding or other similar application.
- (2) A high-speed brushless motor is used to achieve a maximum speed of 80,000 min<sup>-1</sup> and eliminate the nuisance of brush maintenance.
- (3) Speed control and protection functions utilize a high performance microprocessor.
- (4) Automatic control and monitoring of spindle functions are possible.
- (5) Wide speed range, 1,000-80,000 min<sup>-1</sup> makes high precision machining possible.
- (6) Compact control unit design allows easy installation in space restricted machines. Connectors and control panel are front mounted for easy access.
- (7) Control Unit is capable of being connected to AC100V to 240V power sources.
- (8) Two types of control units are available. Standard type NE260 and NE260-OP1 which conforms to European standards for safe, automatic machine operation.
- (9) Gear Mode Select Switch installed. Set Gear Mode to display the rotating speed at the cutting tool when using an angle spindle or speed reducer.

## 3 SPECIFICATIONS

### 3-1 Specifications

#### (1) Control Unit

Model	NE260	NE260-OP1 *Note2	
Input	AC100V-240V, 50/60Hz, 1PHASE, 1.8A		
Output	AC33V, 0-1KHz, 3PHASE, 2.4A		
Operating Temperature	0-40°C		
Ambient Humidity	MAX. 85%		
Over Voltage Category	II		
Pollution Degree	2		
Speed Range	1,000-80,000 min <sup>-1</sup> *Note3		
Control Signal	Input *Note1	Transistor Activation Connections : 6 Analog Connections : 1	Transistor Activation Connections, MOS Relay Contact Connections : 9 Analog Connections : 1
	Output *Note1	Transistor Activation Connections, MOS Relay Contact Connections : 9 Analog Output Connections : 3	Transistor Activation Connections : 9 Relay Contact Connections : 2 Analog Output Connections : 3
Protection Circuits	Over-Voltage, Over-Current, Over Load, Sensor Malfunction, Overheat, Brake Malfunction, Spindle Lock, Low Air Pressure, Start-Up Error, Over-Speed	Over-Voltage, Over-Current, Over Load, Sensor Malfunction, Overheat, Spindle Lock, Brake Malfunction, Low Air Pressure, Start-Up Error, Over-Speed, Emergency Stop Circuit	
Weight	2.8kg		
Dimensions	W88 x D138 x H238 mm		

\*Note1 : Protectively Separated

#### \*Note2 <NE211-OP1 Features>

- The installed Safety Relay is designed to comply with EN standards, 'a' contacts switch the Motor Power Line and 'b' contacts switch the external outputs to the machining center's controller.
- The Safety Relay utilizes Normally Open contacts. The Emergency Stop Signal lines must be supplied with power to hold the Safety Relay contacts closed and allow the control unit to supply power to the motor. Any system errors, trouble with the machining center or the connections between the E3000 control unit and the machining center's controller will cause the relay contacts to open and the E3000 motor to stop.
- The Emergency Stop Signal Input can be connected to any and all portions of the machine's safety systems to stop the E3000 motor any time that stoppage of the spindle and motor is required.
- The 'b' contact outputs can be used to detect an open circuit on the motor line and integrated with the machines safety systems to stop the machine in case of trouble. If the 'a' contacts of the Safety Relay are welded together by an over load or short circuit the 'b' contacts' separation is maintained at more than 0.5mm spacing by the relay's spring release mechanism.

#### \*Note3 <Motor Speed Limited Area>

- Limit motor speed depend on motor types. Before using it, check the specifications of the motor & the motor spindle.
- Control to limit motor speed from 1,000 to 80,000 min<sup>-1</sup> for EM-3080J and HES810. Using Cutting Capacity Motor Speed Area is from 20,000 to 80,000 min<sup>-1</sup>.
  - Control to limit motor speed from 1,000 to 60,000 min<sup>-1</sup> for EM-3060, EM-3060J, EM30-S6000, EM25-S6000 and EM20-S6000.
  - Control to limit motor speed from 1,000 to 50,000 min<sup>-1</sup> for EM25N-5000 and HES510.
  - Control to limit motor speed from 1,000 to 32,000 min<sup>-1</sup> for EM-3030J, EMA-3020K and EMA-3020S.

### 3-2 Diagrams

#### NE260 Control Unit

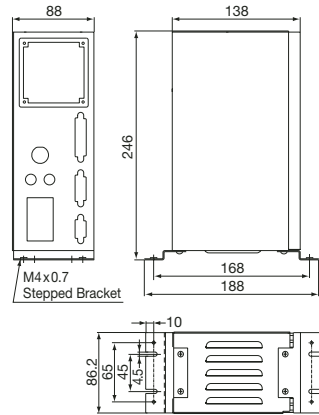

Fig. 1 Bottom Mounting

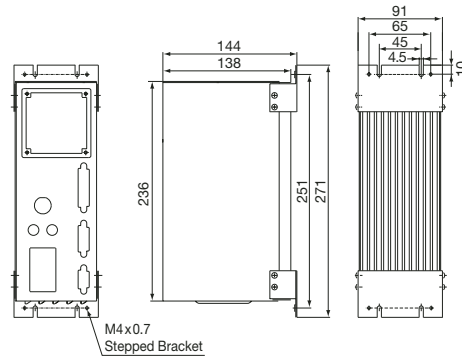

Fig. 2 Back Mounting

### 3-3 Standard Equipment

Model	Standard Equipment · Accessories	
NE260	<ul style="list-style-type: none"> <li>• Power Cord 2m</li> <li>• Reducer</li> <li>• Connector Cap (Provided)</li> <li>• Nylon Tension Relief</li> <li>• Rubber Pad</li> <li>• Operation Manual</li> </ul>	<ul style="list-style-type: none"> <li>• Air Hose with filter</li> <li>• Connector Cover (Provided)</li> <li>• Bracket</li> <li>• Screw</li> <li>• Fuse (T6.3AL) : 2pcs.</li> </ul>

## 4 SYSTEM CHART

### 4-1 Motor Speed 80,000min<sup>-1</sup>

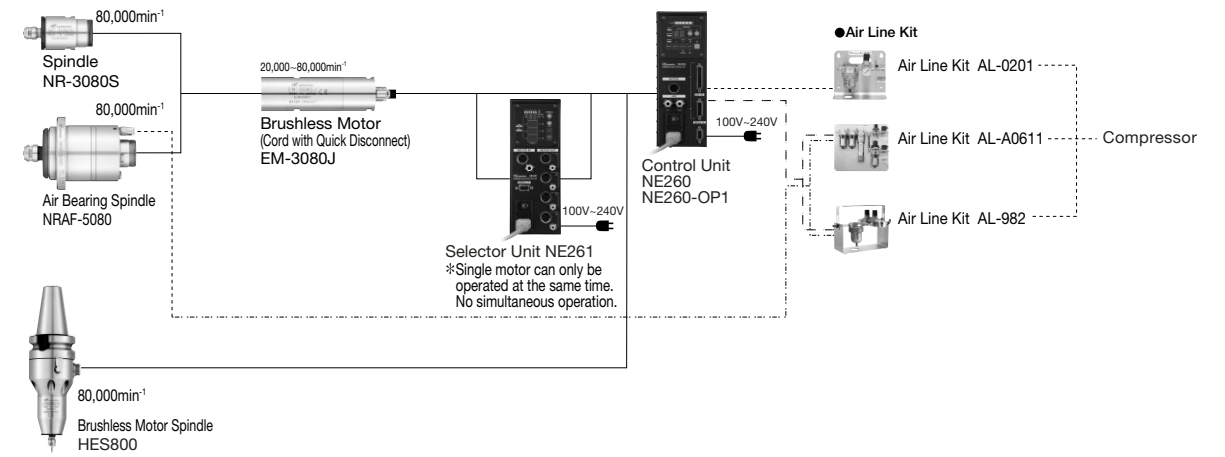

Fig. 3

### 4-2 Motor Speed 60,000min<sup>-1</sup> / 50,000min<sup>-1</sup> / 32,000min<sup>-1</sup>

#### (1) One Piece Type

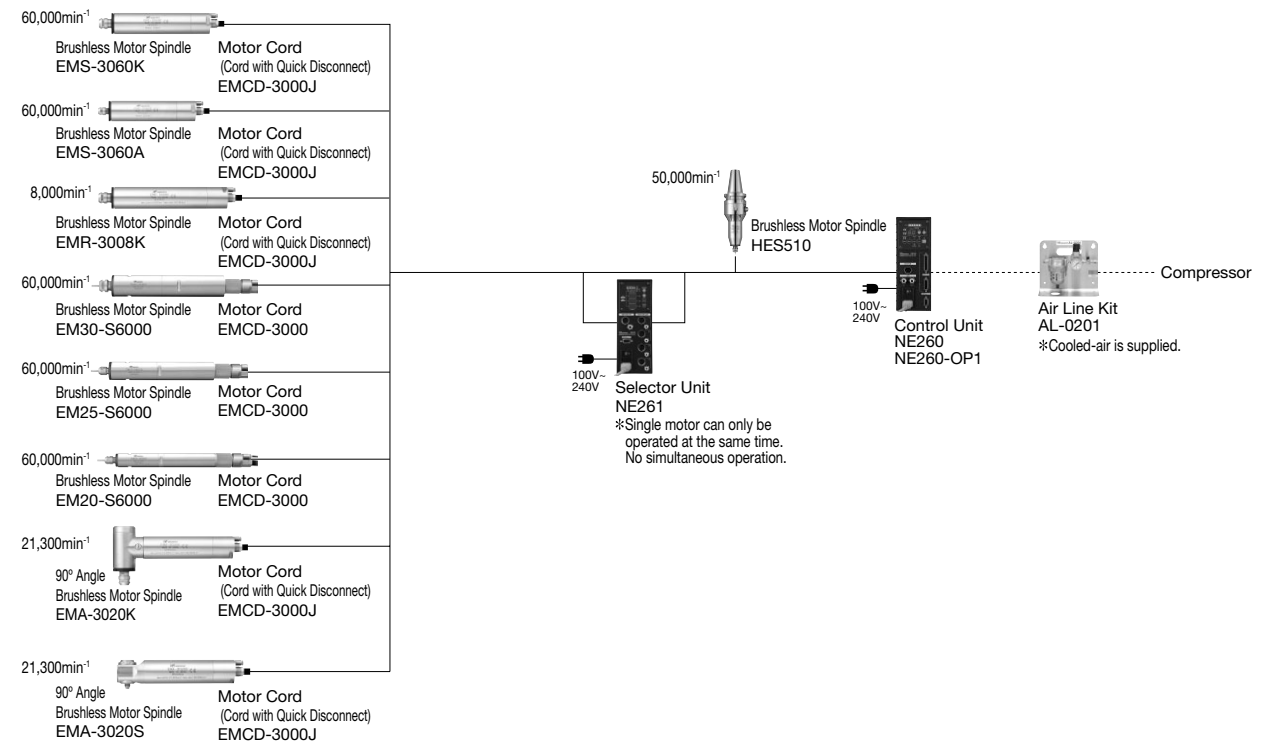
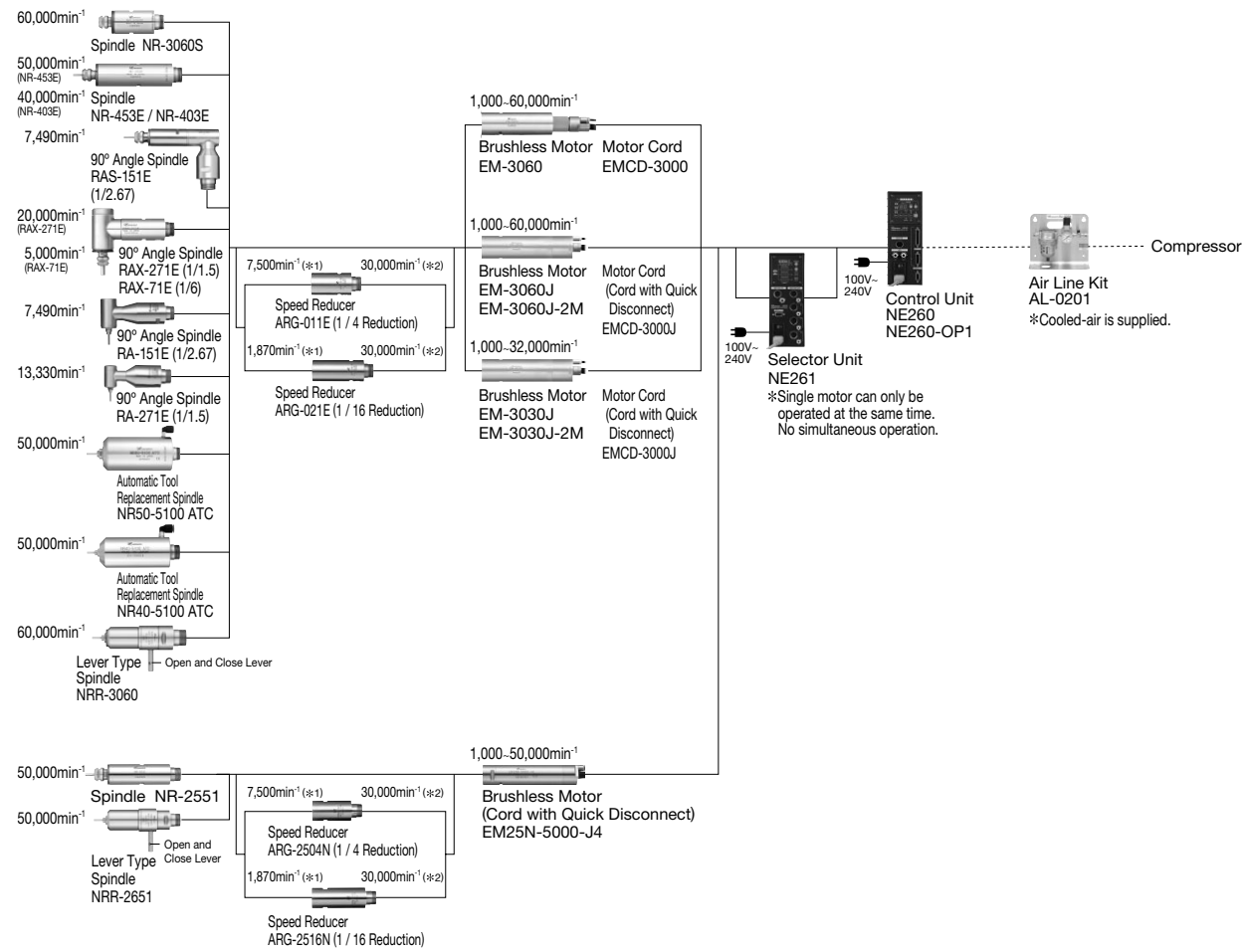

Fig. 4



(2) Modular Type



\* 1 : Maximum rotating speed at the cutting tool.  
 \* 2 : Maximum allowable motor speed for the spindle.

Fig. 5

5 TORQUE CHARACTERISTICS

(1) 80,000min<sup>-1</sup>

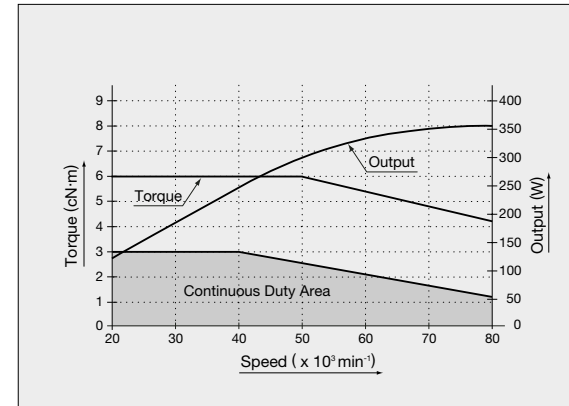

Fig. 6

(2) 60,000min<sup>-1</sup>

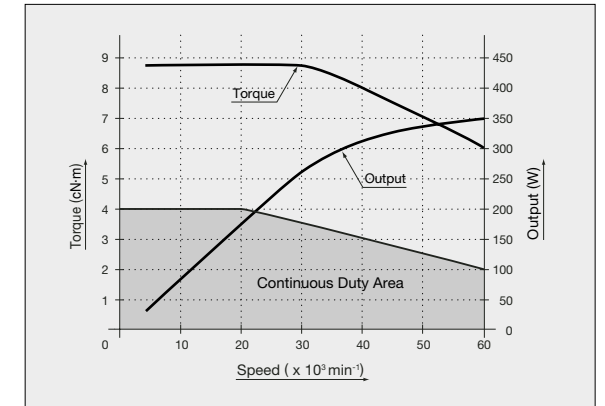

Fig. 7

(3) 50,000min<sup>-1</sup>

① EM25N-5000

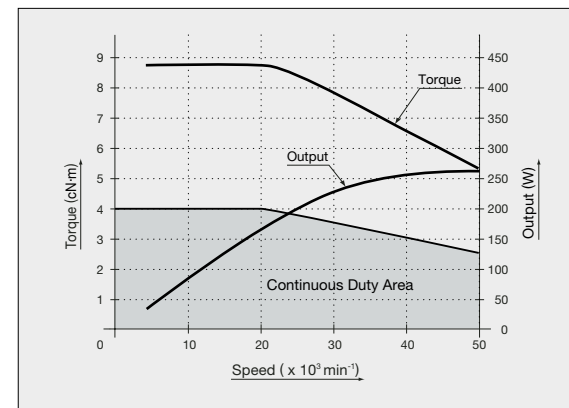

Fig. 8

② HES510

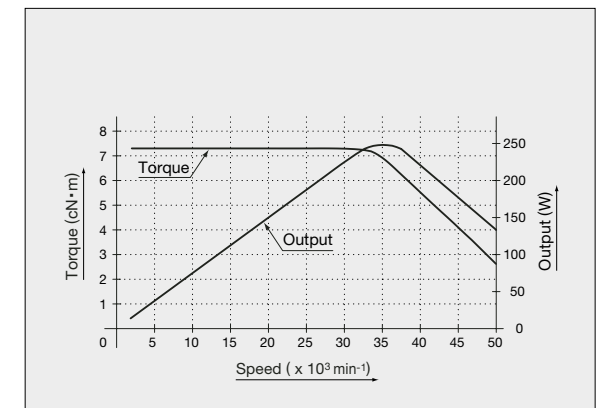

Fig. 9

(4) 32,000min<sup>-1</sup>

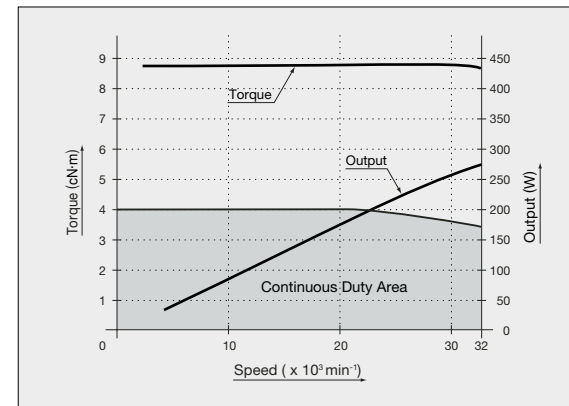

Fig. 10

## 6 NOMENCLATURE

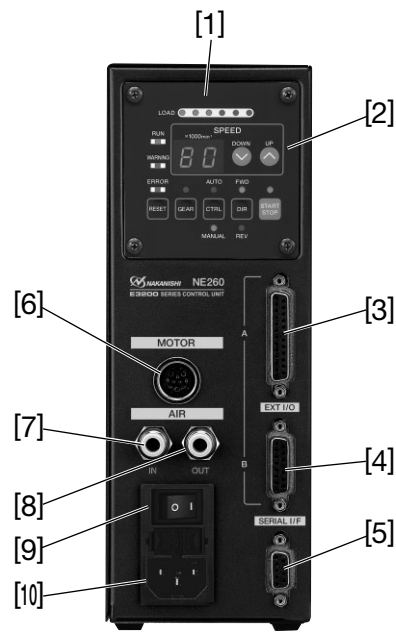

Fig. 11

[1] **Unit (NE260)**

[2] **Control Panel**

Refer to Control Panel details.

[3] **Input/Output Connector A**

Connector for automatic control and monitoring of motor/spindle system. When not in use please install the connector cover to prevent damage or contamination of connector or pins.

[4] **Input/Output Connector B**

Connector for automatic monitoring of emergency conditions. The pin configurations of this connector are different on the NE260 and NE260-OP1. Please refer to page 27 for a complete description of the pin input and output signals. When not in use please install the connector cover to prevent damage or contamination of connector or pins.

[5] **Communication Connector for NE261 Selector Unit**

When not in use please install the connector cover to prevent damage or contamination of connector or pins.

[6] **Motor Connector**

[7] **Air Input Joint**

Supply clean, dry, regulated air for motor cooling. Regulate air to between 0.25MPa-0.3MPa. Air Consumption 30Nℓ/min. Air must be supplied to operate the system.

[8] **Air Output Joint**

Connect Air Hose to supply clean, dry, regulated air for motor cooling.

[9] **Power Switch**

[10] **Main Power Inlet**

Insert the Plug for Power Cord (Provided). Fuse (T6.3AL 250V) : 2pcs.

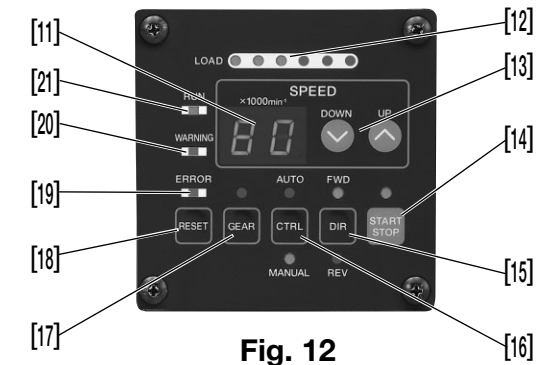

Fig. 12

[11] **Digital Speed Indicator (SPEED)**

Preset Speed, Actual Speed, Warning and Error Codes are displayed to 2 digits. When the motor is stopped the Preset Speed is displayed, when the motor is rotating the actual speed is displayed. The display also displays the error codes when an error has occurred. And displays the gear ratio setting when the gear mode is set.

[12] **Load Monitor LED (LOAD)**

The motor/spindle load is displayed by 6 LED's (3 Green, 2 Yellow and 1 Red). Continuous operation is possible with up to all 3 green LED's lit. If one of the yellow LED's is lit the motor/spindle can only be run for a short time. Please refer to **17 PROTECT FUNCTION** of this manual for allowable duration of high load operation. When any of the yellow or red LED's are lit the warning LED (Warning) [20] will flash, if this condition is continued beyond the allowable interval the error LED (Error) [19] will flash and the motor/spindle will be shut down.

[13] **Motor Speed Adjustment Switch (SPEED)**

Steplessly adjustable speed control. Pushing the UP button will increase motor speed. Speed is adjustable from 1,000-80,000 min<sup>-1</sup>.

[14] **Start Switch (START)**

Starts and stops motor rotation

[15] **Rotation Direction Switch (FWD./REV.)**

Right hand rotation (FWD.) and left hand rotation (REV.) are as viewed with the cutting tool facing the operator. With the cutting tool facing the operator right hand rotation (FWD.) will be clockwise rotation.

[16] **Controller Switch (AUTO-MANUAL)**

This switch selects motor/spindle control from the Control Panel or from an external source.

Manual : Control Panel

Auto : External control through the input/output connector.

[17] **Gear Mode Select Switch (GEAR)**

Set Gear Mode to display the rotating speed at the cutting tool when using an angle spindle or speed reducer. Select the gear ratio by [13] Motor Speed Adjustment Switch. When setting gear mode, the gear ratio will be displayed in [11] Digital Speed Indicator.

[18] **Error Reset Switch (RESET)**

This switch resets and allows restarting of the motor/spindle after an error has been corrected. Some error codes will not allow the unit to be reset until after the power switch has been turned off.

### [19] Error LED (ERROR)

When a serious problem with the system is detected this LED blinks, the motor/spindle is shut down and the Digital Speed Indicator [11] displays the error code.

### [20] Warning LED (WARNING)

The operating and working conditions of the system are constantly monitored and the warning LED blinks when a hazardous condition has been detected. When a hazardous condition is detected the warning LED blinks and the Digital Speed Indicator [11] alternates between the warning code and the actual or preset speed, depending on whether or not the motor/spindle is rotating.

### [21] Rotating LED (RUN)

When the motor is rotating this LED will flash.

## 7 CHANGING FUSES

### ⚠ WARNING

- Before removing fuse make sure that the main power switch is in the off position and the power cord is disconnected from the power supply.
- Make sure and use only the properly rated and type of fuse.
- Failure to use the proper type and rated fuse will result in fire, injury, electric shock and/or product damage.

- (1) Push on the clips on the top and bottom of the fuse holder and remove the fuse holder and fuses.
- (2) Remove the bad fuse or fuses and replace with the proper type and rating of fuse as listed below and determined by the input voltage being used.  
Fuse : T6.3AL (250V)
- (3) Replace the fuse holder containing the fuses into the fuse inlet box and make sure it snaps in place.



Fig. 13

## 8 BRACKET INSTALLATION

### ⚠ CAUTION

- If there is a threat to fall the control unit from the desk, be sure to place it with the provided brackets for safety.
- Never install the unit in such a manner as to block the air vents on the side of the control unit. This manner of installation will cause heat buildup and damage to the internal components of the control unit.

- (1) Two mounting brackets are provided with the system.
- (2) The brackets can be installed on the bottom or on the back of the control unit.
- (3) After installing the brackets you can use the screw cutouts to mount the control unit.

### 8-1 Bottom Mounting

Attach the 2 brackets using the 4 hole on the bottom of the unit using the provided screws.



Fig. 14

### 8-2 Back Mounting

Attach the 2 brackets using the 4 holes on the back of the unit using the provided screws.

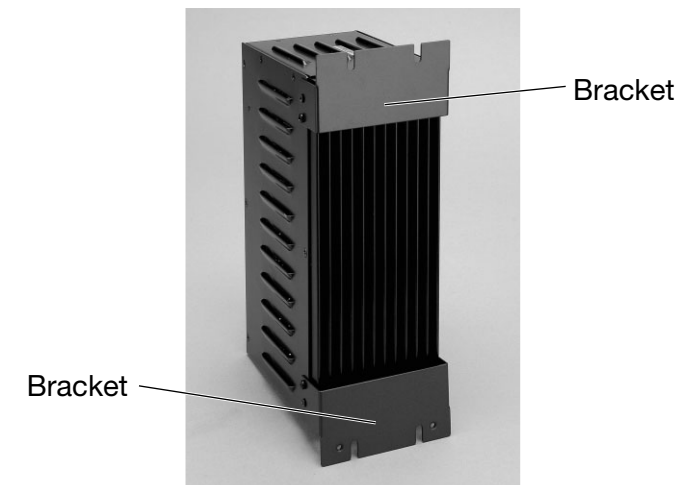

Fig. 15



### 8-3 Rubber Pad Installation

When placing the control unit horizontally, the Rubber Pad (Provided) is installed at the side of the air vents. Install the control unit so the air vents are underneath the control unit. When installing horizontally, remove the 4 screws on the Control Panel and remount the panel at a 90° Angle.

Before removing the control panel be sure the Power Switch is OFF and remove the Power Inlet Cord.

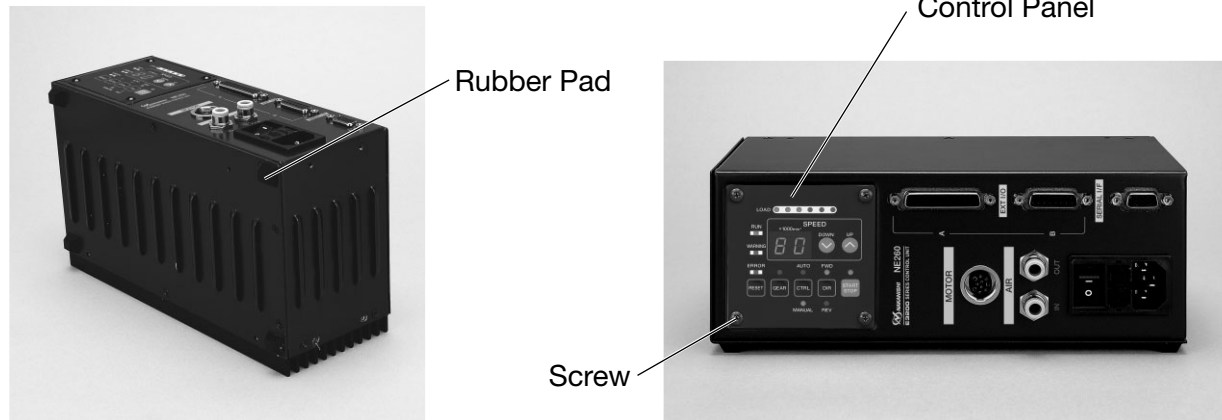

Fig. 16

Fig. 17

### CAUTION

Never install the air vents upward when installing the control unit horizontally. This may cause damage to control unit.

### 8-4 Proper Clearance

When installing 2 or more control units in the machine cabinet make sure to check that each single control unit has the proper clearance on all sides.

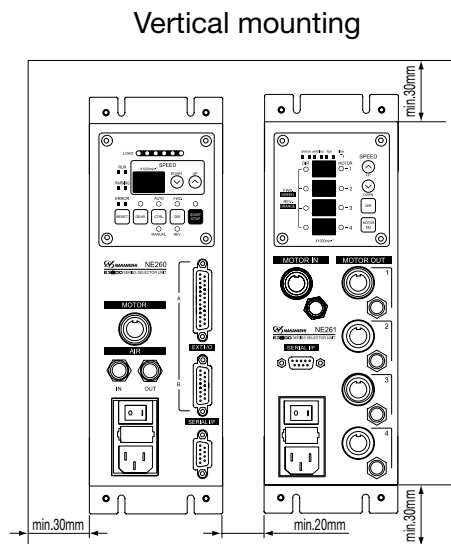

Fig. 18

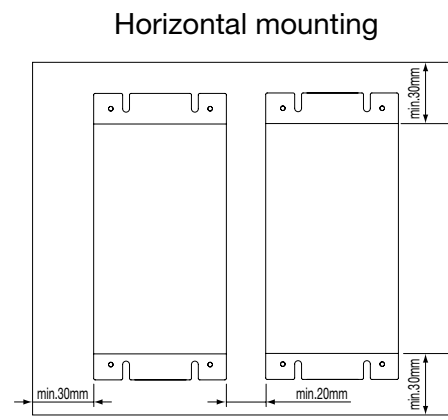

Fig. 19

## 9 POWER CORD CONNECTION

### WARNING

Only use grounded power sources. Failure to properly ground the unit may result in electric shock, injury, fire and/or damage to the system components.

- (1) Insert the female plug into the main power inlet box [10] on the front of the unit.
- (2) A screw hole is provided on the lower, right side of the control unit for attaching the tension relief. Use the provided Nylon Tension Relief to attach the power cord to the side of the control unit.

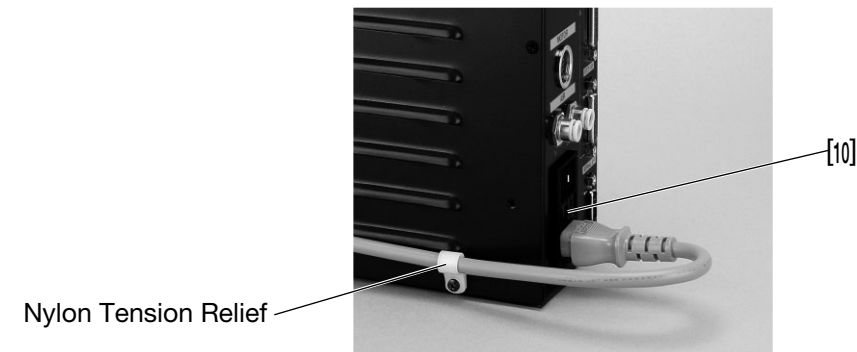

Fig. 20

## 10 MOTOR CORD CONNECTION

- (1) Align the guide pin A on the motor plug with the key way B on the motor socket on the front of the control unit.
- (2) Screw in the coupling nut C of the motor plug to the motor socket D on the front of the control unit.

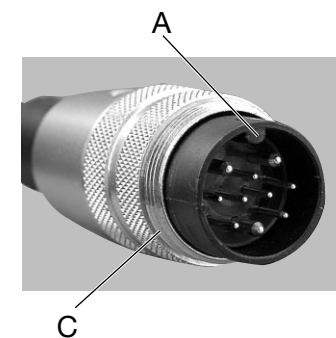

Fig. 21

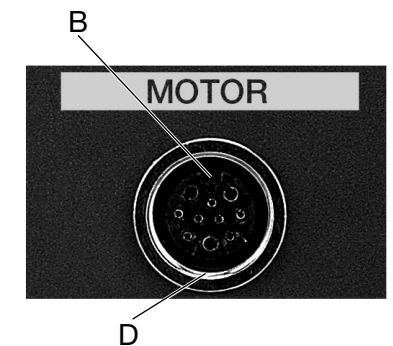

Fig. 22

### CAUTION

Before connecting the motor cord, make sure the power source is switched off.

## 11 AIR HOSE CONNECTION

- (1) Insert the provided  $\varnothing 6\text{mm}$  filtered air hose from the AL-0201 air line kit into the inlet joint [7] on the front of the control unit. (If you are not using the AL-0201 air line kit make sure that the incoming air supply is dry, clean air.)
- (2) Insert one end of the provided  $\varnothing 3.2\text{mm}$  cooling air hose into the back of the motor.
- (3) Insert the other end of the  $\varnothing 4\text{mm}$  cooling air hose into the air output joint [8] on the front of the control unit using the provided  $\varnothing 6\text{mm}$  to  $\varnothing 4\text{mm}$  adaptor.
- (4) Regulate air pressure between 0.25-0.3MPa.

The system can be set to operate without cooling air. Please see parameter setting P7 to set this option. Maximum speed is  $30,000\text{min}^{-1}$  when not using cooling air.

Note : It is not recommended to use the system in this manner for general machining.

This setting is only for light cutting and not for use with coolants.

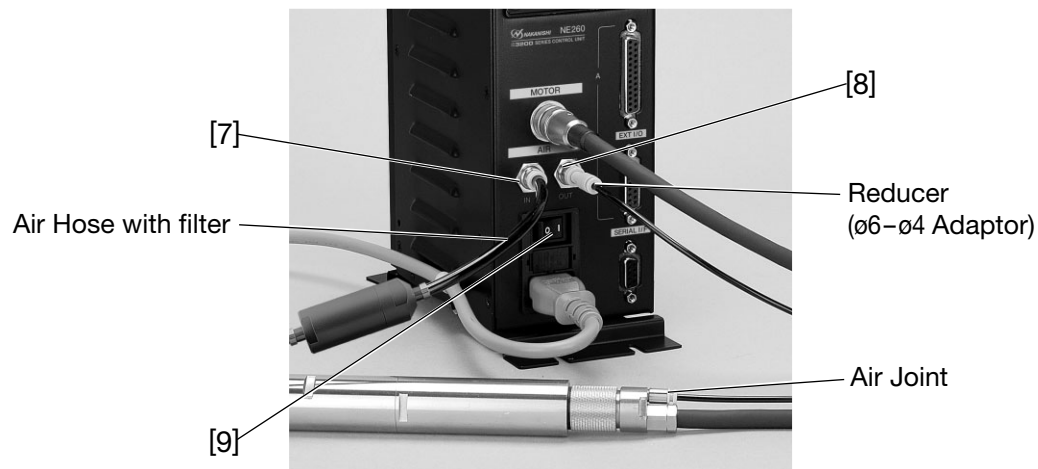

Fig. 23

### ⚠ CAUTION

1. Regulate the air supply between 0.25-0.3MPa. If the air pressure is too low the control unit will not operate.
2. The cooling air provides two functions, to cool the electric motor and to protect the spindle from contaminants. If air supply is shut off do not subject the spindle to direct coolant spray or use in dusty areas.
3. Do not bend the air hose in any sharp bends or pull on the hose this can cause the hose to break, cut off the air supply or weaken the hose over time resulting in deterioration of the motor and spindle.
4. Attach the connector cover (provided) for safety, when not using Input/Output Connector A/B and communication connector.
5. Never supply over the regulated air pressure. There is a threat to damage to the air detect sensor inside the control unit.
6. The air detect function with the control unit is the detector of the input only. When damaging to the air hose of the output of the control unit, can't be able to detect no air supply to the motor spindle.

## 12 CHANGING CUTTING TOOLS

The spanner size and the cutting tool replacement varies depends on the spindle types. Be sure to check the operation manual on the spindle or the motor spindle about the details.

- (1) Set the provided wrench on the spindle.
- (2) Place the provided wrench on the chuck nut and turn it counterclockwise to loosen the collet and remove the cutting tool. (The first turn will loosen the chuck nut, but the tool will not release and turning will become stiff. Keep turning through the stiffness and the collet will open.)
- (3) Insert the new tool and tighten the collet by turning clockwise.

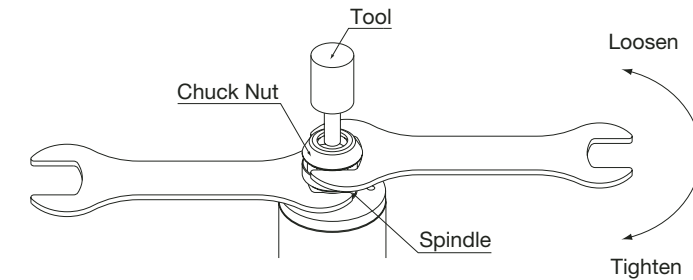

Fig. 24

### ⚠ CAUTION

Never install a collet into the spindle quill without first assembling it in the chuck nut. Do not tighten the collet without mounting a cutting tool or dummy bur as this will result in damage to the collet, spindle and chuck nut and make it impossible to remove the collet.

### 13 REPLACING THE COLLET

The spanner size and the chuck replacement varies depends on the spindle types. Be sure to check the operation manual on the spindle or the motor spindle about the details.

- (1) Remove the cutting tool according to the “12 CHANGING CUTTING TOOLS” procedure above and remove chuck nut assembly. (Fig. 25)
- (2) The collet and chuck nut are held together by a groove in the collet and a flange in the chuck nut. To remove the collet hold the chuck nut in one hand and push diagonally down on the collet. The collet should pop out. (Fig. 25)
- (3) Install the new collet in the chuck nut by positioning the collet in the chuck nut and pressing down on a flat surface. (Fig. 26)

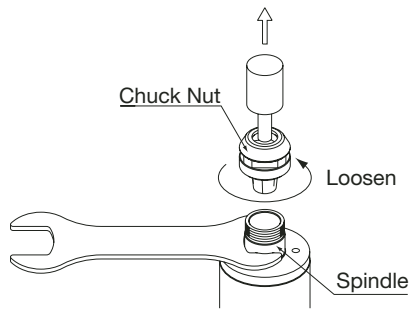

Fig. 25

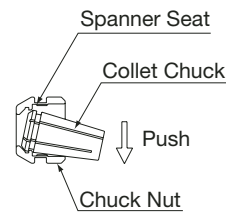

Fig. 26

### 14 FIXTURING THE MOTOR/SPINDLE

- (1) When mounting the motor/spindle, refer to the recommended clamping area. (Fig. 27)  
If the motor/spindle is mounted incorrectly, this will cause and damage to the spindle.  
(The recommended clamping area varies depends on the spindle types. Please check the operation manual on the spindle or the motor spindle about the details.)

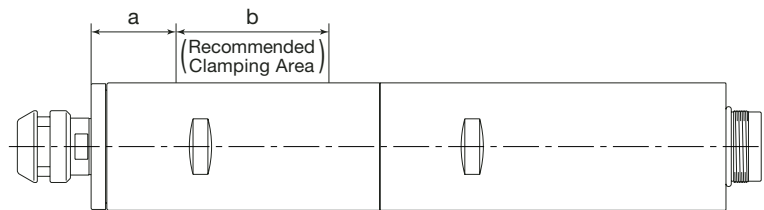

Fig. 27

- (2) The installation shown in Fig. 28 is the recommended fixturing method. If this is not possible, install as shown in Fig. 29. Do not use set screws directly in contact with the motor or spindle body as shown in Fig. 30, this will result in damage to the housing and internal components. When mounting the spindle take care not to fixture over the bearings as this will result in bearing damage.

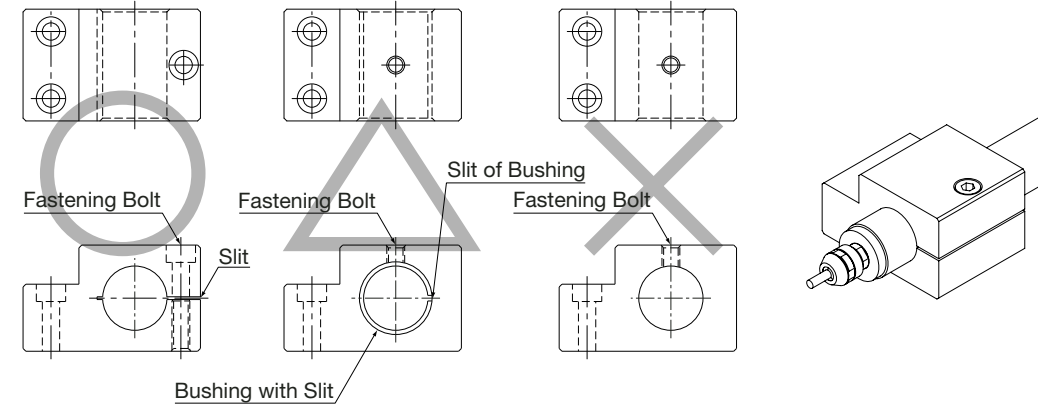

Fig. 28

Fig. 29

Fig. 30

#### ⚠ WARNING

When installing a motor/spindle to a fixed base, make sure the fixed base is grounded in order to avoid the risk of an electric shock.

#### ⚠ CAUTION

- **Caution about tightening the bolt**  
Do not over tighten the bolt. This may cause damage to the spindle's precision. Tighten the bolt until the spindle body can not be turned by hand within the Fixture. Apply working force and check that the spindle is tight before use.
- **Caution about split type Holder**  
Insert a shim into the holder bore, and tighten the bolt with the specified torque. Manufacture the holder with roundness and cylindrical tolerance of less than 5 $\mu$ m. Insert a thin shim into the split in the holder and reduce the shim size in 5 $\mu$ m increments until the spindle is held firmly.  
Tighten the clamping bolt to the torque specified for that size and type of bolt. The final responsibility for ensuring a product's suitability for use in a given application is left to the designer of the equipment in which NAKANISHI's spindle is installed. NAKANISHI offers spindles with a wide variety of capabilities and specifications. Please carefully check the product's specifications against the requirements of your application and verify suitability and safety prior to initial use.

## 15 OPERATION PROCEDURES

### 1. Select Control Mode (Manual/Auto)

- (1) Using the control switch [16] you can select between Manual (Front Panel Control) or Auto (External Signal Source) modes. External Signal Source can be used to control Motor Start/Stop, Rotational Direction, Motor Speed, and etc.
- (2) Manual Mode-Front Panel Operation.  
Auto Mode-Control by External Signal Source.

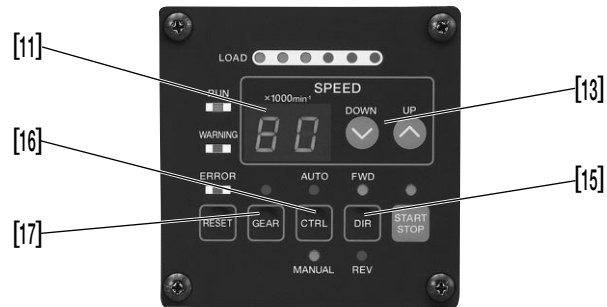

Fig. 31

### 2. Setting motor rotating direction, gear ratio (GEAR), Motor Start/Stop, Motor Speed

#### 2-1 Setting Manual Mode

- (1) Set motor rotating direction  
Push the motor rotating direction switch [15].  
Select FWD. Right hand rotation  
Select REV. Left hand rotation
- (2) Set 500 min<sup>-1</sup> centering rotation  
To select 0.5 (500 min<sup>-1</sup>), stop the motor and push Motor Speed Adjustment Switch [13] to lower the motor speed. The Display Indicator will show 5 then 0.5. Never attempt to cut while rotating in the centering mode.
- (3) Setting Gear Ratio  
Push Gear Mode Switch [17]. Check the spindle or gear reducer gear ratio, select the correct gear ratio by pushing Motor Speed Adjustment Switch [13].  
Display Indicator [11] will show the selected gear ratio. 5 possible gear ratios can be selected as the follows 1.0, 1.5, 2.7, 4.0, 16.  
If you are not using the straight type speed reducer or an angle type spindle, you do not need to set Gear Ratio Mode. (Use Gear Ratio 1.0)  
When Gear Mode is active the dot after the second digit on the Display Indicator will flash.
- (4) Motor Start/Stop  
Push Start Switch [14] and START LED will illuminate.

### (5) Setting Motor Speed

Set the speed by pushing the Motor Speed Adjustment Switch [13].

- Motor Speed Range is 1,000-80,000 min<sup>-1</sup>.  
If the air pressure is too low the control unit will not operate.
- The motor speed is displayed in 1,000 min<sup>-1</sup>. 80 equals 80,000 min<sup>-1</sup>.
- During Gear Mode operation the speed change rate of the Motor Speed Adjustment Switch will change.

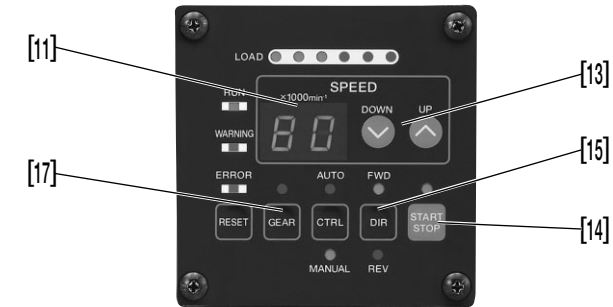

Fig. 32

#### 2-2 Setting Auto Mode

All the functions of the system can be controlled by input control signals to Input/Output Connector A [3] (Except setting gear ratio)

- (1) Set motor rotating direction  
Input the motor rotating direction signal to Pin No. 2 : DIR\_IN  
Right hand rotation is OFF 'Open' ("FWD." LED will light)  
Left hand rotation is ON 'Closed' ("REV." LED will light)
- (2) Set 500 min<sup>-1</sup> rotation  
Input the centering rotation signal to Pin No. 16 : 500 min<sup>-1</sup>  
500 min<sup>-1</sup> LED will light  
Never use 500 min<sup>-1</sup> centering rotation for cutting
- (3) Setting Gear Ratio  
Push Gear Ratio Switch [17]. Check the spindle/reducer gear ratio, select the gear ratio by pushing the Motor Speed Adjustment Switch [13].  
Display Indicator [11] will display the gear ratio as follows 1.0, 1.5, 2.7, 4.0, 16.  
If you are not using the straight type speed reducer or an angle type spindle, you do not need to set Gear Ratio Mode. (Use Gear Ratio 1.0)
- (4) Motor Start/Stop  
Input the motor start signal to Pin No. 14 : START  
Motor rotating is ON 'Closed' (START LED will light)  
Motor stopped is OFF 'Open' (START LED is Off)
- (5) Setting Motor Speed  
Input the motor speed signal to Pin No. 23 : VR  
• Motor Speed Range is 1,000-80,000 min<sup>-1</sup>  
If the air pressure is too low the control unit will not operate.  
• The motor speed is displayed in 1,000 min<sup>-1</sup>. 80 equals 80,000 min<sup>-1</sup>

### 3. Setting other Motor Speed Parameters

The following Motor Speed Parameters can also be preset.

- Error Output Signal.
- Front Panel or External Signal Speed Control during Auto Mode Operation.
- Fix the Motor Rotation Speed.
- Set the maximum motor speed.
- Auto Control Mode Speed Adjustment Method.
- Motor Start Command Signal Method.
- Air Input monitoring override.
- Setting Motor Speed Control Signal.
- Confirmation of Parameter Settings.

If an error occurs an error signal is output to the Input/Output Connectors. The default setting is ON ('Closed') and OFF ('Open'), this setting can be reversed if desired. Please refer to the Setting of Parameters section of this manual for details on reversing these signals.

## 16 EXTERNAL INPUT/OUTPUT CONTROL SIGNAL SPECIFICATIONS

### 1. Connector A

#### (1) Input/Output Connector A

Pin No.	Pin Name	Description	Input/Output	Signal	Function
1	COM_1	External Power Source for External Inputs	Input	0V or +24V DC	Power Source to be used for External Inputs.
2	DIR_IN	Rotating Direction Signal	Input	OFF (Open) : FWD. ON (Closed) : REV.	Controls the direction of rotation of the motor.
3	CNT_IN	Count Pulse Signal for setting Motor Speed	Input	OFF (Open) → ON (Closed)	Count Pulse for setting Motor Speed. (Need to set parameter)
4	RESET	Error Release Signal	Input	ON (Closed) → OFF (Open)	Error code can be released and the system restarted by switching this signal OFF and ON.
5	SEL1	Motor Select Signal 1	Input	OFF (Open) ON (Closed)	Select Motor (Refer to Table 1) Input Signal when using Selector Unit NE261.
6	RUN	Rotating Signal	Output	ON (Closed) : Motor Rotating OFF (Open) : Motor Stopped	Voltage output shows that the motor is rotating.
7	DIR_OUT	Rotating Direction Signal	Output	OFF (Open) : FWD. ON (Closed) : REV.	Voltage output shows the direction the motor is rotating.
8	ERR	Error Signal	Output	ON (Closed) : Normal OFF (Open) : Error	Error has occurred. (*1) Error Code is displayed on the Digital Speed Display.
9	-	Not Used	-	-	————— (*2)
10	GND	Internal GND	Output	Internal GND	This GND to be used for motor speed control circuit. (Refer to Fig.37)
11	VCC	Internal Power Source for Analog Signal	Output	+10V DC	Power Source for VR Output +10V DC
12	MOTOR_1	Motor Current Monitor	Output	0-10V DC 0V : 0A 10V : 20A	Voltage Output shows the motor current consumption. Output voltage is proportional to the motor current consumption.
13	GND	Internal GND	Output	Internal GND	This GND to be used for analog outputs (12, 24 and 25) circuit. (Refer to Fig.40)
14	START	Rotate Command Signal	Input	ON (Closed) : Rotation OFF (Open) : Stop	Starts and Stops motor rotation.

Pin No.	Pin Name	Description	Input/Output	Signal	Function
15	UD-IN	UP/DOWN Signal for Motor Speed Signal	Input	ON (Closed) : Speed Up OFF (Open) : Speed Down	When Cut-IN Signal is in, 1,000 min <sup>-1</sup> speed up.
16	500 min <sup>-1</sup>	Rotates Motor at 'Centering' Speed	Input	ON (Closed) : 500 min <sup>-1</sup> OFF (Open) : Normal Operation	Maintains constant 500 min <sup>-1</sup> motor speed for centering.
17	SEL0	Motor Selection Signal 0	Input	OFF (Open) ON (Closed)	Select Motor (Refer to Table 1) Input when using Selector Unit NE261.
18	COM_2	Power Source for External Outputs	Output	0V or +24V DC	Power Source to be used for External Output Signals.
19	PULSE	Rotating Pulse	Output	1 pulse/rotation	1 revolution of the motor generates one pulse. Duty 50%
20	WARNING	Warning Signal	Output	OFF (Open) : Normal Operation ON (Closed) : Warning	This output shows a Warning has occurred. The Warning Code is shown on the Digital Speed Indicator.
21	COIN	Speed Achievement Signal	Output	ON (Closed) : Ordered Speed Achieved OFF (Open) : Ordered Speed Not Achieved	Voltage output shows that the motor has achieved more than 90% of the set speed.
22	-	Not Used	-	-	————— (*2)
23	VR	Motor Speed Control Signal	Input	0-10V DC 0V : 1,000 min <sup>-1</sup> 8V+ : 80,000 min <sup>-1</sup>	Sets rotating speed of Motor.
24	LOAD	Torque Load Monitor	Output	0-10V DC 0V : 0% 10V : 200%	Voltage output shows the torque being applied to the motor. Load monitor voltage x 20 equals the torque load %. 20V=Load%
25	SPEED_V	Rotating Speed Monitor Voltage	Output	0-10V DC 1V : 10,000 min <sup>-1</sup> 8V : 80,000 min <sup>-1</sup>	Voltage Output is proportional to the motor speed.

\*1 The error signal output can be reversed. Please refer to the setting of parameters section of this manual.

\*2  **CAUTION**

**Never use the pins marked NOT USED.**

Table 1 Motor Selection Signal

Select Motor	SEL1 (Pin No. 5)	SEL0 (Pin No. 17)
Motor 1	OFF (Open)	OFF (Open)
Motor 2	OFF (Open)	ON (Closed)
Motor 3	ON (Closed)	OFF (Open)
Motor 4	ON (Closed)	ON (Closed)

\*Table 1 Motor Selection Signal is effective when using Selector Unit NE261.

## (2) Input/Output Diagram

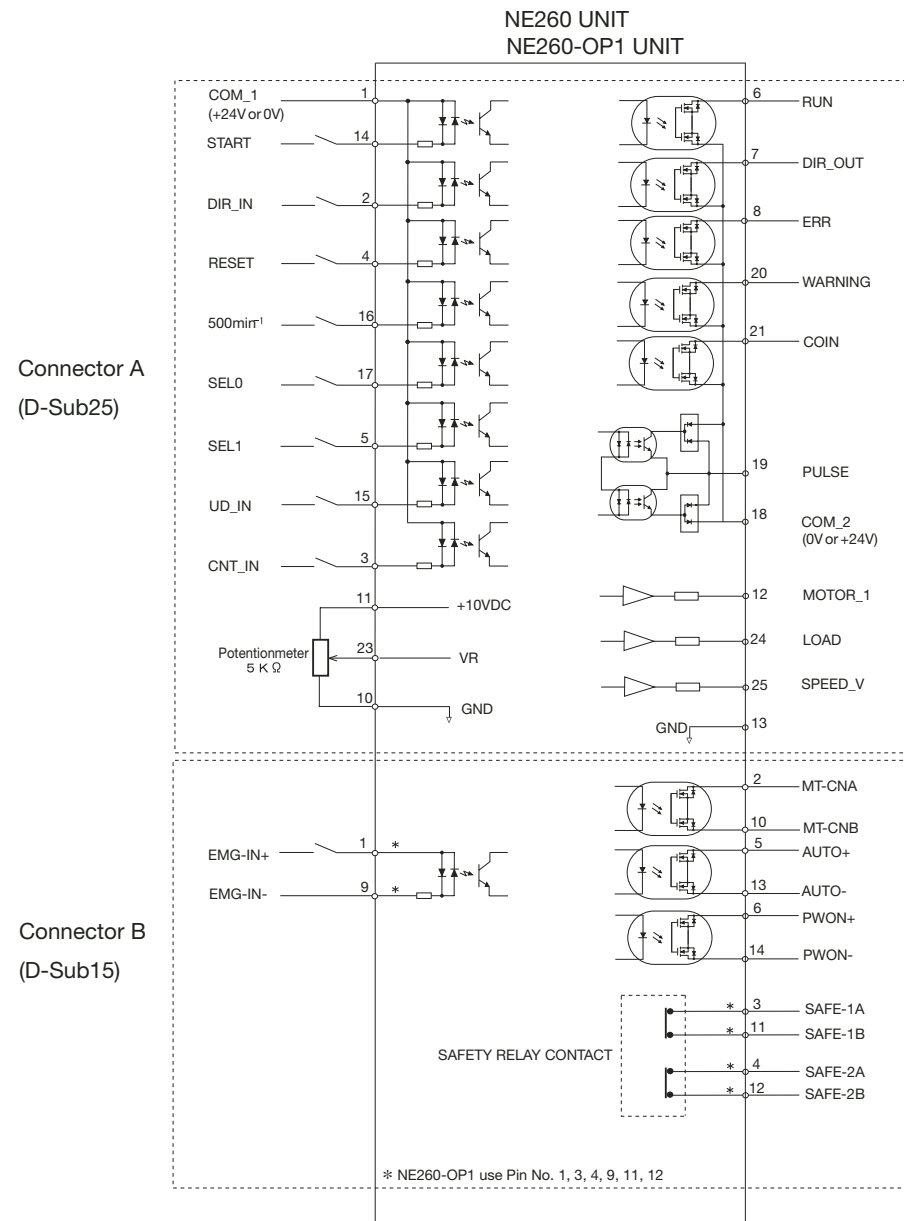

Fig. 33

## (3) Input/Output Signal

### ① Input Signal

There are 8 kinds of input signals : rotation command, rotation direction, error release, speed up-down signal, speed command pulse signal, motor selection signal 0, motor selection signal 1, 500 min<sup>-1</sup> speed command. These signals are +24VDC signals from an external signal source.

Please use a separate power source that is capable of supplying 24VDC±10 %, 100mA. Refer to Figures below for connections.

\*When using NE261, input signal : Motor Selection Signal 0, Motor Selection Signal 1.

\*By setting parameter, Motor Speed change is possible by pulse signal.

If input "Speed up-down signal" "Speed Command pulse signal".

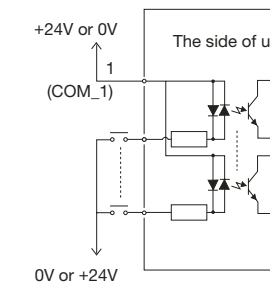

Fig. 34

### ② Output Signal I

There are 5 kinds of output signals : rotating, rotating direction, error, warning and rotating speed achieved. These signals are MOSS Relay Contact Connections. The output current can be connected to both the sink and the source.

Voltage and Current Specifications

- Applied Voltage (V max) ≤ 30VDC
- Working Current (I<sub>p</sub>) ≤ 100mA

Use an external power source for output circuits.

It is recommended to use the same 24VDC power source used for input signals. Please refer to Fig. 35 for connections.

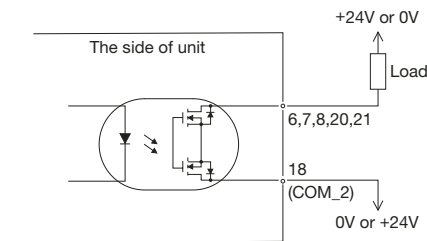

Fig. 35

### ③ Output Signal II

Refer to Fig. 36 for about the Output Signal of Rotating Pulse. The output current can be connected to both the sink and the source.

Voltage and Current Specifications

- Applied Voltage (V max) ≤ 30VDC
- Working Current (I<sub>p</sub>) ≤ 50mA

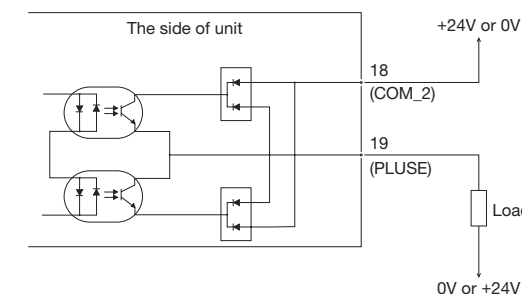

Fig. 36



④ Motor Speed Control Signal

Refer to Fig. 37, 38, 39 for connections.

\*When applying the voltage, never input over 10VDC. This will avoid damaging to the control unit.

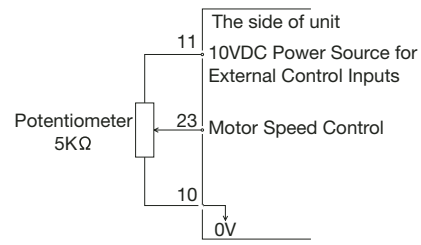

Fig. 37

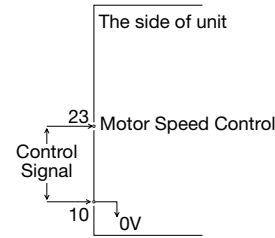

Fig. 38

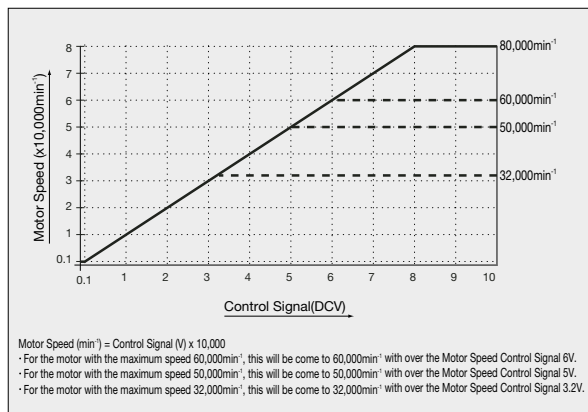

Fig. 39

⑤ Monitoring Signals

There are 3 kinds of monitoring signals : Motor Current, Torque Load Monitor and Rotating Speed Monitor. Please refer to Fig. 40 for connections.

- Motor Current Monitor
- Torque Load Monitor
- Rotating Speed Monitor Voltage

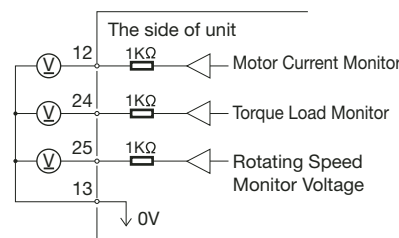

Fig. 40

2. Connector B

If you use NE260-OP1 connected to a machine tool, connect the signal line of SAFE-1A, SAFE-1B, SAFE-2A, SAFE-2B to the safety circuit at the side of the machinery in order to build a safety shutdown system with higher reliability.

(1) Input/Output Connector B

**CAUTION**

**NE260 does not use PIN No. 1, 3, 4, 9, 11, 12.**  
**NE260-OP1 use PIN No. 1, 3, 4, 9, 11, 12.**

Pin No.	Pin Name	Description	Input/Output	Signal	Function
1	EMG-IN+	Emergency Stop Signal	Input	External Power Source input for Emergency Stop Signal or Emergency Stop Signal OFF (Open)	External Power Source input for Emergency Stop Signal or Emergency Stop Signal. Normal Operation ON (Closed), Emergency OFF (Open).
2	MT-CNA	Motor Signal Connect Contact A	Output	Continuity, OFF (Open), between PIN2 and PIN10 the motor is connected.	When there is continuity, OFF, between PIN2 and PIN10 the selected motor is connected, if no continuity the motor is disconnected or the motor cord is broken.
3	SAFE-1A	Safety Relay Contact 1A	Output	PIN3 and PIN11 continuity ON (Closed) Safety Relay is OFF	When there is continuity between PIN3 and PIN11 ON (Closed) Safety Relay is OFF (System Stopped), no continuity Safety Relay is OFF (Open) Normal Operation.
4	SAFE-2A	Safety Relay Contact 2A	Output	PIN4 and PIN12 continuity ON (Closed) Safety Relay is OFF	When there is continuity between PIN4 and PIN12 ON (Closed) Safety Relay is OFF (System Stopped), no continuity Safety Relay is OFF (Open) Normal Operation.
5	AUTO+	AUTO Mode Signal (+)	Output	Auto Mode Operation PIN5 and PIN13 ON (Closed)	When AUTO Mode is being used this Pin5 & PIN13 is ON (Closed).
6	PWON+	Unit Power Source Monitor (+)	Output	ON (Closed) : Main Power Supply is connected OFF (Open) : Main Power Supply is disconnected	If the main power supply to the unit is connected this output is ON (Closed).
7	—	Not Used	—	—	—
8	—	Not Used	—	—	—
9	EMG-IN-	Emergency Stop Signal (-)	Input	External Power Source input for Emergency Stop Signal or Emergency Stop Signal OFF (Open)	External Power Source input for Emergency Stop Signal or Emergency Stop Signal. Normal Operation ON (Closed), Emergency OFF (Open).
10	MT-CNB	Motor Signal Connect Contact B	Output	Continuity, OFF (Open), between PIN2 and PIN10 the motor is connected.	When there is continuity, OFF, between PIN2 and PIN10 the selected motor is connected, if no continuity the motor is disconnected or the motor cord is broken.
11	SAFE-1B	Safety Relay Contact 1B	Output	PIN3 and PIN11 continuity ON (Closed) Safety Relay is OFF	When there is continuity between PIN3 and PIN11 ON (Closed) Safety Relay is OFF (System Stopped), no continuity Safety Relay is OFF (Open) Normal Operation.
12	SAFE-2B	Safety Relay Contact 2B	Output	PIN4 and PIN12 continuity ON (Closed) Safety Relay is OFF	When there is continuity between PIN4 and PIN12 ON (Closed) Safety Relay is OFF (System Stopped), no continuity Safety Relay is OFF (Open) Normal Operation.
13	AUTO-	AUTO Mode Signal (-)	Output	Auto Mode Operation ON (Closed)	When AUTO Mode is being used this Pin is ON (Closed).
14	PWON-	Unit Power Source Monitor (-)	Output	ON (Closed) : Main Power Supply is connected OFF (Open) : Main Power Supply is disconnected	If the main power supply to the unit is connected this output is ON (Closed).
15	—	Not Used	—	—	—

**CAUTION**

**When using 0V DO NOT connect to PIN10 or 13 (Internal Ground) of Input/Output Connector A.**

## (2) Input/Output Signals

### ① Output Signal

#### **PIN No. 2-10, 5-13, 6-14**

There are 3 kinds of output signals : “Motor Connection Monitoring”, “AUTO MODE” and “Unit Power Source Monitoring”.

These signals are MOSS Relay Contact Connections. The output current can be connected to both the sink and the source

Voltage and Current Specifications

- Applied Voltage (V max)  $\leq$  30VDC
- Working Current (Ip)  $\leq$  100mA

Use an external power source for output circuits. It is recommended to use a separate power from the one used for Input/Output Connector A. Please refer to Fig. 41 for connections.

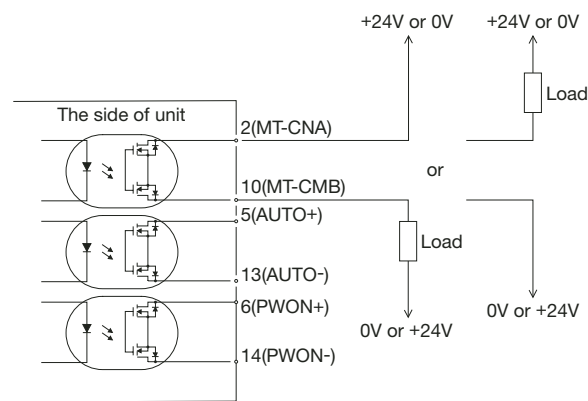

**Fig. 41**

### ② Emergency Stop Signal Input

#### **PIN No. 1-9**

This signal is a switched 24V DC output.

Please use a separate power source that is capable of supplying 24VDC $\pm$ 10%, 50mA. Refer to Fig. 42 below for connections.

Normal Operation circuit is ON (Closed) Emergency Stop circuit is OFF (Open).

If the Emergency Stop Signal is OFF (Open) the Safety Relay is OFF and the power supply to the motor is interrupted and the motor stops.

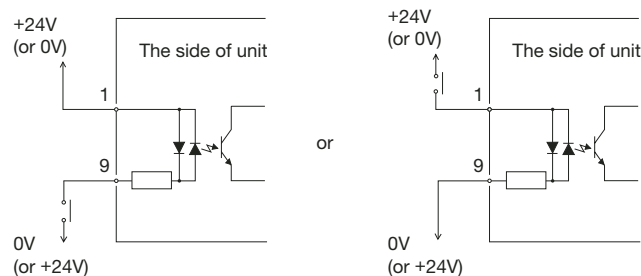

**Fig. 42**

### ③ Safety Relay Signal

#### **PIN No. 3-11, 4-12**

- The Safety Relay will be ON or OFF depending on the state of the Emergency Stop Signal PIN1-9.
- When there is continuity between PIN3 (SAFE-1A) and PIN11 (SAFE-1B) or between PIN4 (SAFE-2A) and PIN12 (SAFE-2B) the motor is off. If there is no continuity between these pairs of pins then the system is operating normally.
- If the Emergency Stop Signal is OFF (Open) the Safety Relay will be OFF (Open) and the motor power will be interrupted and the motor will stop.
- If the ‘a’ contacts of the Safety Relay are welded together by an over load or short circuit the ‘b’ contacts’ separation are maintained with more than 0.5mm spacing by the relay’s recoil mechanism.
- The voltage/current specifications of PIN3-11 & PIN4-12.

Applied Voltage (V max)  $\leq$  30VDC

Working Current (Ip)  $\leq$  2A

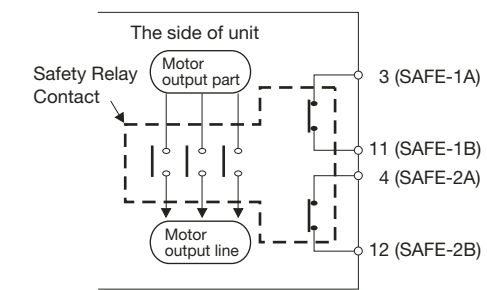

**Fig. 43**

## 3. Input/Output Signal Connector Specifications

### ① Input/Output Connector A

Plug Part Number : XM2A-2501 OMRON (or other similar high-quality product)

Cover Part Number : XM2S-2511 OMRON (or other similar high-quality product)

### ② Input/Output Connector B

Plug Part Number : XM2A-1501 OMRON (or other similar high-quality product)

Cover Part Number : XM2S-1511 OMRON (or other similar high-quality product)

- The Plug and Cover are not provided with the system. Please purchase the specified plug and cover from local suppliers.
- Use only shielded cables to minimize RF interference and noise. Connect the shield to the plug cover.
- Different makers use different names for the cover.

### **⚠ CAUTION**

**To minimize RF interference and noise please keep the length of the cables as short as practical and route separate from power cables.**

#### 4. Input/Output Connector A, B Pin Configuration

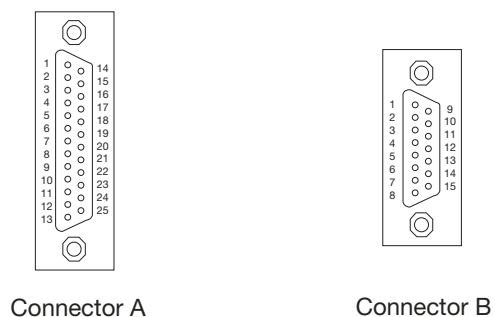

Fig. 44

## 17 PROTECT FUNCTION

### 1. Warning Function

Always check the control unit, motor, spindle and the condition of the cooling air prior to use. This will help prevent system errors that will result in undesired operating conditions.

- (1) The Warning LED [20] will flash.
- (2) The Warning Code (listed in Table 2) will be displayed on the Digital Speed Indicator [11].
- (3) A Warning Signal is output to the Warning Signal (PIN No. 20 : WARNING) of Input/Output Connector A.

Table 2

Warning Code	Warning Function	Trouble
A0	Motor Cord	Motor Cord or Connector is disconnected or misaligned
A1	Low Air Pressure	Low Air Pressure
A2	Control Unit Overheat	Internal Temperature of the Control Unit too High
A3	Over Load	Motor Torque load exceeding safe limits
A4	Emergency Stop	Emergency Stop system activated
A5	Over Air Pressure	Over Air Supply

### ⚠ CAUTION

When the Warning LED [20] flashes, please check the Warning code.

### 2. Detection of unsafe operating conditions

Always check the control unit, motor, spindle and the condition of the cooling air prior to use. This will help prevent system errors that will result in undesired operating conditions.

When an Error Occurs the following events happen :

- (1) Motor stops
- (2) The Error LED [19] will flash.
- (3) Error Code (listed in Table 3) will be displayed on the Digital Speed Indicator [11].
- (4) An Error signal is output to the Error Signal (PIN No. 8 : ERR) of Input/Output Connector.

### 3. Resetting System after Error Codes

There are 2 methods of releasing error codes.

- (1) Push Error Reset Switch [18] RESET on the front panel.
- (2) Switch the signal on PIN4 (RESET) of Input/Output Connector A OFF (Open) → ON (Closed) → OFF (Open).

When releasing Error using the Motor Start/Stop (Pin No. 14 : START) is ON (Closed), OFF (Open) Motor Start/Stop before resuming operation.

Table 3

Error Code	Problem Area	Trouble
E1	Excess Current	Motor Current beyond safe limits
E2	Over voltage	Motor Voltage beyond safe limits
E3	Motor Sensor	Trouble with the sensor signal in the motor
E4	Control Unit Overheat	Internal Temperature of the Control Unit too High
E5	Brake Circuit Trouble	Trouble with the motor brake circuit
E6	Rotor Lock	Motor stalled for more than 3 seconds
E7	Low Air Pressure	Inadequate air supplied for more than 4 seconds during rotation or inadequate air supply when motor start commanded.
E8	Torque Overload	Torque limits exceeded for too long a period of time.
E9	Communication Interception	Intercept communication with Selector Unit (NE261) (Only if using NE260 connect to NE261)
EA	External Control Signal Error	External control sequencing problem
EL	Incompatible Motor	Incompatible motor is connected to the system.
EH	Over Speed	Rotating speed is beyond the set speed for too long
EE	Emergency Stop Error	Safety Relay has been activated and the Emergency Stop System has stopped the motor
EC	Internal Memory Error	Trouble with memory (EEPROM)

### ⚠ CAUTION

- When using the Input/Output Connector and external monitoring please check and resolve the source of the trouble anytime a Warning Code is displayed.
- When the error occurs for the damage to the internal of the control unit, can not release the error. Please send to Nakanishi repairs.

#### 4. Torque Overload

When the Load Monitor LED (Load) [12] lights 4 or more LEDs (3 green LEDs and 1 or more yellow LEDs) an overload condition exists. During overload operation the follow occurs.

- (1) Warning LED (Warning) [20] flashes
- (2) Warning Code A3 is displayed on the Digital Speed Indicator [11]
- (3) Warning Signal is output to the Warning Signal (Warning) of Input/Output Connector

Overload operation is considered short term operation mode. The allowable operation time depends on the number of lighted LEDs on the Load Monitor LED (Load).

The allowable time is detailed below.

- (1) Load Monitor LED 4 LEDs : 30 Seconds
- (2) Load Monitor LED 5 LEDs : 10 Seconds
- (3) Load Monitor LED 6 LEDs : 5 Seconds

When the allowable time is exceeded the motor will stop and the following occurs.

- (1) Error LED (Error) [19] flashes
- (2) Error Code E8 is displayed in the Digital Speed Indicator [11].
- (3) Error Signal is output to the error signal PIN8 (ERR) of Input/Output Connector A.

#### ⚠ CAUTION

**If you operate the system in short term operation for long periods of time the control unit will overheat and damage to the motor and spindle is possible. NAKANISHI recommends only continuous duty operation (Load LED has 3 LEDs lit : Torque Load Monitor (Load) voltage is less than 5V.**

### 18 BREAK-IN PROCEDURE

The E3200 Series is a high-precision, high-speed motor-spindle, the following procedure must be followed to ensure proper operation and longevity.

During transportation, storage or installation the grease inside the bearings will settle. If the motor-spindle is suddenly run at high-speed excessive heat will cause bearing damage. After installation, repair, initial operation, or long periods of non operation please follow the break-in procedure detailed in Table 4.

Table 4

Steps	1	2	3	4	5	6
min <sup>-1</sup>	15,000	30,000	40,000	50,000	60,000	80,000
Running Time	15 Min	10 Min	10 Min	15 Min	10 Min	10 Min
Items to Check	No Abnormal Noises	Spindle Housing no hotter than 20°C. If hotter than 20°C stop for at least 20 minutes, check installation and restart Break-In procedure.			Spindle Housing less than 20°C.	

### 19 CUTTING TOOL CAUTIONS

- (1) The proper surface speed for vitrified grindstones is 600-1800m/min.

#### ⚠ CAUTION

**Do not exceed a surface speed of 2,000m/min for grinding.**

$$\text{Surface Speed (m/min)} = \frac{3.14 \times \text{Diameter (mm)} \times \text{rotation speed min}^{-1}}{1,000}$$

- (2) Do not exceed 13mm overhang for mounted grindstones. In case overhang must exceed 13mm reduce the motor speed in accordance with Fig. 45 and Table 5.
- (3) Do not use tools with bent or broken shanks, cracks or excessive runout.
- (4) Dress the grindstone prior to use.
- (5) For grinding the maximum depth of cut should not exceed 0.01mm radially or axially. Reciprocate the tool several times after each in feed step.
- (6) Always operate tools within the tool manufacturer's recommended speed limits. Use of a tool outside of the manufacturer's recommended speed limits could cause damage to the spindle and injury to the operator.
- (7) Keep the tool shank and collet clean. If contaminants are left in the collet they can cause excessive runout and damage the tool and spindle.
- (8) Do not drop or hit spindle.

Table 5. Overhang and Speed

Overhang (mm)	Speed (min <sup>-1</sup> )
20	N x 0.5
25	N x 0.3
50	N x 0.1

N=Max. operating speed at 13mm overhang.

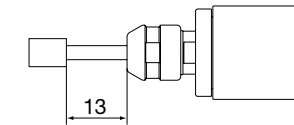

Fig. 45

## 20 TROUBLE SHOOTING

Trouble	Cause	Inspect/Corrective Action
Motor Does Not Run	Power is not supplied.	<ul style="list-style-type: none"> <li>•Check the Main Power Inlet connection on the front of the unit.</li> <li>•Insert the Power Plug correctly.</li> <li>•Check if the fuse is short.</li> </ul>
	Motor Cord or Connector Disconnected.	Connect the Motor Cord to the connector or check the Motor Cable.
	Controller Switch is set to Manual but trying to start with an external command signal through Input/Output Connector A.	Start with the Start Switch on the Control Panel, or set the Controller Switch to Auto.
	Controller Switch is set to Auto but trying to start with the Start Switch on the Control Panel.	Start with an external command signal or set the Controller Switch to Manual.
	Motor Cord is connected to the wrong Motor Connector on NE261. Emergency Stop Signal on Input/Output Connector B is OFF (Open) NE260-OP1 Only.	Check the Motor Cord connection and correct if necessary. Check the source of the Emergency Stop Signal and correct the problem. After correcting the problem, restart the system.
	Error Code Indicated.	Check and correct the source of the Error Code.
	Low Air Pressure	Adjust air pressure to between 0.25MPa-0.3MPa.
Motor Speed is not displayed correctly	Motor Fixed Speed is set in the $P3$ or $P4$ parameters.	Check the $P3$ and $P4$ parameter settings and adjust as needed.
	Set Gear Mode except "1.0".	Check the gear ratio.
High Run-Out	Foreign Particles stuck in the collet chuck or spindle.	Clean the inside of the collet chuck and spindle.
	Collet Nut is not properly positioned.	Position the collet nut properly.
	Ball Bearings Worn.	Send to NAKANISHI for Repair.
Abnormal Vibration or Noise during Operation	Foreign Particles in the ball bearings. Ball Bearings Worn.	Send to NAKANISHI for Repair.
	Tool out of Balance.	Change the tool.

## 21 SETTING OF OPERATING PARAMETERS

(1) The following operating parameters can be preset depending on the application requirements. The operating parameter presets are retained in non-volatile memory and will be maintained even if power is disconnected.

### ① Setting the Error Output Mode

When an operating error occurs, an error signal will be output to Input/Output Connector A. This output can be set to normally ON (Closed) or normally OFF (Open).

### ② Setting AUTO Mode Motor Speed Control

Control Mode is set to AUTO

- Motor Speed can be controlled by the Motor Speed Adjustment Switch on the Control Panel.
- When using Selector Unit NE261, Motor Speed can be adjusted on the NE261 control panel.

### ③ Setting Fixed Motor Speed for Motor #1 and #2 and #3 and #4

- Single Motor Speed is desired.
- Machine Operator can not change motor speed.

### ④ Setting the Maximum Motor Speed for Motor #1 and #2 and #3 and #4

- Set maximum motor speed to the maximum allowable speed for the cutting tools being used.
- Set the maximum motor speed to the maximum recommended speed for the spindle being used.

### ⑤ Selection of external Input/Output Signal Speed

During Auto mode operation, you can select variable voltage DC or pulse signal to control motor Speed.

### ⑥ Selection of the type of external signal for motor start method

Allows selection of Start signal and Direction Signal or REV. Start and FWD. Start signals.

### ⑦ Air Input monitoring override

The system can be configured to operate without cooling air, maximum speed is 30,000 min<sup>-1</sup>.

### ⑧ Setting Motor Speed Control Signal

There is the compatibility with E3000C Control unit about Motor Speed Control Signal. When setting the Motor Speed Control Signal, the maximum motor speed is 60,000min<sup>-1</sup>. When connecting to the motor spindle with the maximum motor speed 80,000min<sup>-1</sup>, be sure to control to limit the motor speed less than 60,000 min<sup>-1</sup>. When the Parameter  $P8$  is OFF or ON, the relation with external motor speed control signal and motor speed shows Fig. 46 & Fig. 47.

The Characteristics when the Parameter  $P8$  is OFF

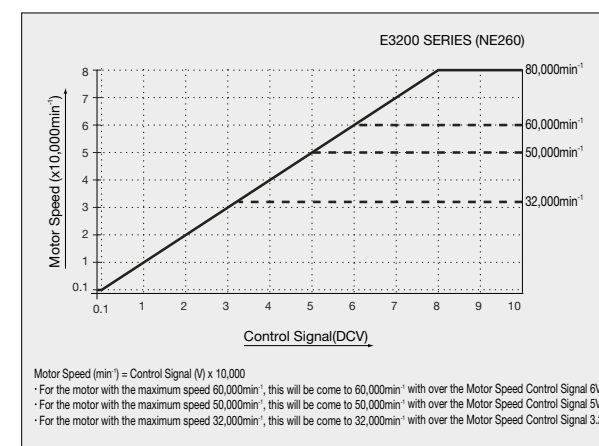

Fig. 46

The Characteristics when the Parameter  $P8$  is ON

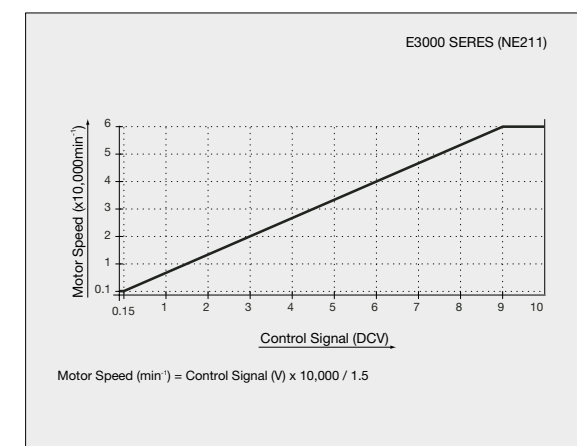

Fig. 47

### ⑨ Check operating parameter settings



## (2) Entering Parameter Setting Mode

While pushing and holding the Error Reset Switch [18] turn the Power Switch [9] On. Hold the Reset Switch down for 3 seconds, the buzzer will 'beep' 3 times, release the Reset button and Parameter Setting Mode will start. The Start LED flashes to indicate Parameter Setting Mode is active.

- After entering Parameter Setting Mode the parameters to be set can be selected by pushing the Motor Speed Adjustment Switch.

**P1** - **P9**

- P1** Error Output Mode
- P2** AUTO Mode Motor Speed Control
- P3** Fixed Motor Speed
- P4** Maximum Motor Speed
- P5** External Speed Control Mode
- P6** External Motor Start Signal Control Mode
- P7** Air Input monitoring override
- P8** Setting Motor Speed Control Signal
- P9** **P1** - **P8** Confirm settings of parameters **P1** - **P8**

## (3) Setting Procedure

### ① Setting Error Output Mode **P1**

- Allows setting of the output signal on PIN No. 8 : ERR of Input/Output Connector A.
- When an error occurs the output can be set to ON (Closed) or OFF (Open).

#### Procedure

1. Push the Start Switch.
2. **OFF** is displayed. This indicates that when an error occurs the output will be OFF (Open).
3. Push the Start Switch.
4. **ON** is displayed. This indicates that when an error occurs the output will be ON (Closed).
5. You can cycle through the choices by pushing the Start Switch.
6. Push the Reset Switch to send the settings to memory **P1** will be displayed depending on the parameter being set.
7. If you desire to set other parameters push the Motor Speed Adjustment Switch to select the parameter to be set.
8. If you are finished setting parameters, turn the Power Switch off.

If the Error Output Mode has been changed from the default setting, that setting will be displayed the next you enter Parameter Setting Mode.

### ② Setting AUTO Mode Motor Speed Control **P2**

- Allows the setting of the manner in which motor speed can be controlled when the system is being used in AUTO mode (External Command Signal Control).
- This parameter selects between speed control with the Motor Speed Adjustment Switch or by External Command Signal through Input/Output Connector A.

#### Procedure

1. Push the Start Switch.
2. **OFF** is displayed. This indicates that speed control is by External Command Signal Control and the Motor Speed Adjustment Switch are Disabled.
3. Push the Start Switch.
4. **ON** is displayed. This indicates that speed control is by the Motor Speed Adjustment Switch and the External Command Signal Control for speed is disabled.
5. You can cycle through the choices by pushing the Start Switch.
6. Push the Reset Switch to send the settings to memory **P2** will be displayed depending on the parameter being set.
7. If you desire to set other parameters push the Motor Speed Adjustment Switch to select the parameter to be set.
8. If you are finished setting parameters, turn the Power Switch off.

### ③ Setting Fixed Motor Speed **P3**

- Allows the motor speed to be fixed.
- Fixes the motor speed in both MANUAL and AUTO modes.

#### Procedure

1. Push the Start Switch.
2. **OFF** is displayed. This indicates that Fixed Motor Speed cannot be set.
3. Push the Start Switch.
4. **ON** is displayed. This indicates that Fixed Motor Speed can be set.
5. The Digital Speed Indicator will oscillate between **ON** and the selected motor speed. The motor speed can be set by pushing the Motor Speed Adjustment Switch. The speed control range is 1,000-80,000 min<sup>-1</sup>.
6. Push the Reset Switch to send the settings to memory **P3** will be displayed depending on the parameter being set.
7. If you desire to set other parameters push the Motor Speed Adjustment Switch to select the parameter to be set.
8. If you are finished setting parameters, turn the Power Switch off.



#### ④ Setting Maximum Motor Speed P4

- Allows the maximum motor speed to be set.
- Fixes the motor speed in both MANUAL and AUTO modes.

##### Procedure

1. Push the Start Switch.
2. 0F is displayed. This indicates that the Maximum Motor Speed cannot be set.
3. Push the Start Switch.
4. 0n is displayed. This indicates that the Maximum Motor Speed can be set.
5. The Digital Speed Indicator will oscillate between 0n the selected motor speed and motor speed can be selected by pushing the Motor Speed Adjustment Switch. The speed control range is 1,000-80,000 min<sup>-1</sup>.
6. Push the Reset Switch to send the settings to memory P4 will be displayed depending on the parameter being set.
7. If you desire to set other parameters push the Motor Speed Adjustment Switch to select the parameter to be set.
8. If you are finished setting parameters, turn the Power Switch off.

#### ⑤ Setting External Speed Control Mode P5

- Allows the setting of External Speed Control Mode.
- The External Speed Control signal can be either a variable voltage DC signal or a pulse signal.
- Set Input/Output signal (Pin No. 23 : VR) or set Pulse (Pin No. 3 : CNT-IN/Pin No. 15 : UD-IN)
- When using the PULSE signal, Speed up (Open) or Speed down (Closed) is selected by using the UD-IN signal, and change the motor speed is changed by the CNT-IN signal the motor speed change/pulse is 1,000 min<sup>-1</sup>/pulse.

##### Procedure

1. Push the Start Switch.
2. 0F is displayed. The motor speed is controlled by Input/Output Signal Connector A (Pin No. 23 : VR).
3. Push the Start Switch.
4. 0n is displayed. The motor speed is controlled by Input/Output Signal Connector A (Pin No. 3 : CUT-IN, Pin No. 15 : UD-IN).
5. Push the Reset Switch to send the settings to memory P5 will be displayed depending on the parameter being set.
6. If you desire to set other parameters push the Motor Speed Adjustment Switch to select the parameter to be set.
7. If you are finished setting parameters, turn the Power Switch off.

#### ⑥ Setting External Motor Start Signal Control Mode P6

- During Auto Control Mode the motor Start signal can either by a direction signal and a Start signal or a FWD. Start and a REV. Start signal. When P6 is set to 0F the rotation direction is controlled by Pin No. 2 DIR\_IN, FWD. (Open), REV. (Closed) and the Start signal is controlled by Pin No. 14 : START When P6 is set to 0n FWD. rotation is controlled by Pin No. 14 : START and REV. rotation is controlled by Pin No. 2 : DIR\_IN.

##### Procedure

1. Push the Start Switch.
2. 0F is displayed. This indicates that the control mode is set to direction signal and start signal.
3. Push the Start Switch.
4. 0n is displayed. This indicates that control mode is set to FWD. ON, REV. ON mode.
5. Push the Error Reset Switch to send the settings to memory P6 will be displayed depending on the parameter being set.
6. If you desire to set other parameters push the Motor Speed Adjustment Switch to select the parameter to be set.
7. If you are finished setting parameters, turn the Power Switch off.

#### ⑦ Setting Air Input monitoring override P7

- The system can be set to operate without cooling air. Maximum speed is 30,000min<sup>-1</sup> in either case using cooling air or not.  
Note : It is not recommended to use the system in this manner for general machining. This setting is only for light cutting and not for use with coolants.

##### Procedure

1. Push the Start Switch.
2. 0F is displayed. This indicates that the control mode is set to direction signal and start signal.
3. Push the Start Switch.
4. 0n is displayed. The system can be configured to operate without cooling air, maximum speed is 30,000 min<sup>-1</sup>.
5. Push the Error Reset Switch to send the settings to memory P7 will be displayed depending on the parameter being set.
6. If you desire to set other parameters push the Motor Speed Adjustment Switch to select the parameter to be set.
7. If you are finished setting parameters, turn the Power Switch off.

### ⑧ Setting Motor Speed Control Signal $P8$

- There is the compatibility with E3000C Control unit about Motor Speed Control Signal. When setting the Motor Speed Control Signal, the maximum motor speed is 60,000min<sup>-1</sup>. When connecting to the motor spindle with the maximum motor speed 80,000min<sup>-1</sup>, be sure to control to limit the motor speed less than 60,000min<sup>-1</sup>. When the Parameter  $P8$  is OFF or ON, the relation with external motor speed control signal and motor speed shows Fig. 45 & Fig. 46.

#### Procedure

1. Push the Start Switch.
2.  $oF$  is displayed. When setting the parameter, the relation motor speed with control signal.  
Motor Speed (min<sup>-1</sup>) = Control Signal (V) x 10,000
3. Push the Start Switch.
4.  $oN$  is displayed. When setting the parameter, the relation motor speed with control signal.  
Motor Speed (min<sup>-1</sup>) = Control Signal (V) x 10,000/1.5
5. Push the Error Reset Switch to send the settings to memory  $P8$  will be displayed depending on the parameter being set.
6. If you desire to set other parameters push the Motor Speed Adjustment Switch to select the parameter to be set.
7. If you are finished setting parameters, turn the Power Switch off.

### ⑨ Confirmation of the Parameter Settings $P9$

- Allows user to check the settings of the above parameters  $P1$  -  $P8$

#### Procedure

1. Push the Start Switch.
2. Display oscillates between  $P1$  and the setting for  $oF$  or  $oN$
3. Push the Start Switch.
4. Display  $P2$  and oscillates between  $P2$  and the setting for  $oF$  or  $oN$
5. Push the Start Switch.
6. Display oscillates between  $P3$  and the setting for  $oF$  or setting motor speed.  
(For example, display 30 for 30,000 min<sup>-1</sup>)
7. Push the Start Switch.
8. Display oscillates between  $P4$  and the setting for  $oF$  or Max. motor speed.
9. Push the Start Switch.
10. Display oscillates between  $P5$  and the setting for  $oF$  or  $oN$
11. Push the Start Switch.
12. Display oscillates between  $P6$  and the setting for  $oF$  or  $oN$
13. Push the Start Switch.
14. Display oscillates between  $P7$  and the setting for  $oF$  or  $oN$
15. Push the Start Switch.
16. Display oscillates between  $P8$  and the setting for  $oF$  or  $oN$
17. Push the Start Switch.
18. Return to setting Parameter or push Error Reset Switch to finish.

#### (4) Default Parameter Settings

When the system is shipped from NAKANISHI's factory all parameters.  $P1$  -  $P8$  are set to  $oF$

#### (5) Control Panel Setting Resume Function

On power up the system will resume all the Control Panel settings in the position they were in when the system was shut off.

The following settings will be maintained :

1. Motor Speed
2. Rotating Direction (FWD., REV.)
3. Control Mode (AUTO, MANUAL)
4. Gear Ratio Setting
5. Parameter Settings  $P1$  -  $P8$