

PS Series

PSA-40, 45, 50, 60

OPERATION MANUAL

OM-K0231E Rev.A

Thank you for purchasing PS Series Spindle.

PS Series spindles are designed for heavy duty drilling, milling and cutting on space restricted machines. Please read this Operation Manual carefully before use, in order to ensure proper usage and care.

1 ⚠ Caution in Handling

- PS series are not hand tool. Use PS Series installing it on a lathe, NC lathe, a specially engineered machine and/or automated machine etc.
- Use protect cover around PS series and wear protect eye glasses while in operation since it runs. Do not touch on the spindle while it is running.
- Tighten the collet chuck firmly not to come off during the operation. Before start running the spindle, confirm if the collet chuck is tightened firmly.
- Please be especially careful not to hit or crash the bearing caps as this will create unbalanced rotation causing excessive vibration, heat build up and wear.
- Clean the collet chuck often because the collet chuck and the spindle may be hurt and create the cause of run-out if the debris and polishing powder are sticking in the spindle and the collet chuck.
- Do not exceed spindle speed, refer to 4. Allowable Max. Speed.

2 Features

- Spindle body is precision ground stainless steel (SUS-416) making mounting extremely easy.
- Spindle has a labyrinth debris protection system built in and for extreme, conditions positive air pressure protection is available.
- Spindle is available in outer diameters from 20mm to 60mm, high speed type, low speed type, stainless steel bearing type, high speed steel bearing type and ceramic bearing type.

3 Dimensions

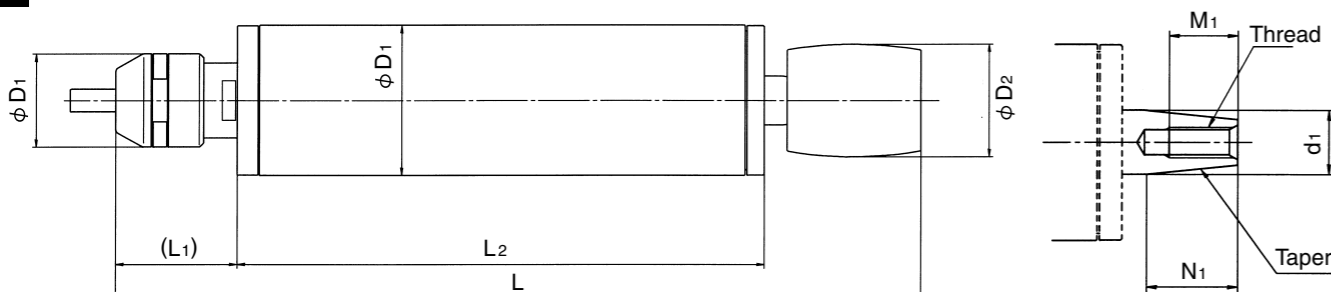

Fig. 1

Table-1

Model	φ D	φ D ₁	φ D ₂	L	L ₁	L ₂	Chuck	Spanner	φ d ₁	N ₁	M ₁	Thread	Taper
PSA40-140	40		30	212.8	31.8	140	CHL	15×17	13	18.5	14	M6×1	1 / 5
PSA40-200				272.8		200		22×27					
PSA45-160	45	24.8	35	237.8	160	20×24							
PSA45-220				297.8	220	22×27							
PSA50-180	50		40	262.8	35.1	180	CHE	22×27	17	23.5	17	M8×1.25	
PSA50-240				322.8		240		22×27					
PSA60-200	60	27.8	45	291.1	200	20×24							
PSA60-260				351.1	260	22×27							

4 Allowable Max. speed

Use under the allowable Max. speed.

Table-2

Model	Specification	Allowable Max. speed	Model	Specification	Allowable Max. speed
PSA40-140N	Standard speed	13,000	PSA50-180N	Standard speed	9,000
PSA40-140H	High speed	26,000	PSA50-180H	High speed	18,000
PSA40-140C	High speed (Ceramic bearing type)	26,000	PSA50-180C	High speed (Ceramic bearing type)	18,000
PSA40-200N	Standard speed	13,000	PSA50-240N	Standard speed	9,000
PSA40-200H	High speed	26,000	PSA50-240H	High speed	18,000
PSA40-200C	High speed (Ceramic bearing type)	26,000	PSA50-240C	High speed (Ceramic bearing type)	18,000
PSA45-160N	Standard speed	11,000	PSA60-200N	Standard speed	8,000
PSA45-160H	High speed	22,000	PSA60-200H	High speed	16,000
PSA45-160C	High speed (Ceramic bearing type)	22,000	PSA60-200C	High speed (Ceramic bearing type)	16,000
PSA45-220N	Standard speed	11,000	PSA60-260N	Standard speed	8,000
PSA45-220H	High speed	22,000	PSA60-260H	High speed	16,000
PSA45-220C	High speed (Ceramic bearing type)	22,000	PSA60-260C	High speed (Ceramic bearing type)	16,000

5 Replacing cutting tool

- Place provided spanner wrench on the spindle.
- Place other provided spanner wrench on the collet cap and turn it counter-clockwise to loosen the collet cap and pull out the tool. Collet and collet cap are linked together so that 2 full turns may be required to fully open the collet.
- Remove old tool and replace with new one. Turn collet cap spanner wrench clockwise to fit tightly.

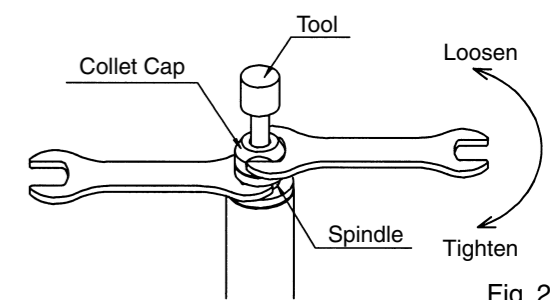

Fig. 2

6 Replacing Collet Chuck

- Follow steps ①&② above (Replacing cutting tool), and remove collet cap assembly. (Fig. 3)
- Collet and Collet cap are linked together. Hold collet cap firmly in one hand and pull out the collet chuck while moving it from left to right to dislodge the collet chuck. (Fig. 4)
- Choose a new collet chuck and insert it into collet cap diagonally to match the collet groove and collet cap hook. (Fig. 5)
- Insert a tool in collet chuck and mount it into the spindle, and turn it clockwise.

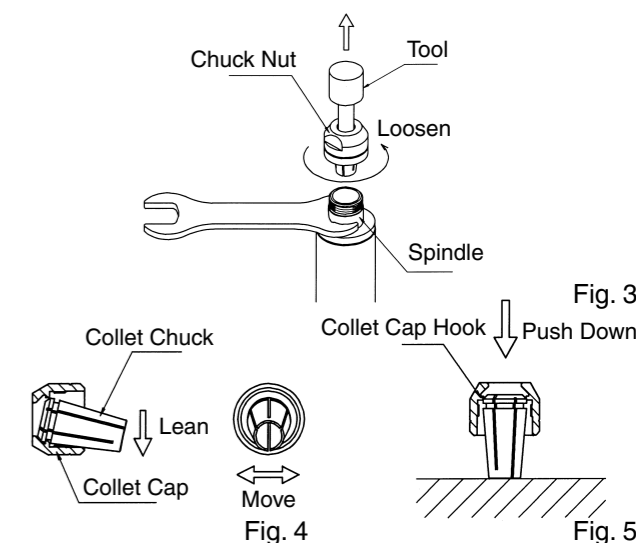

Fig. 3

Fig. 5

CHL : Standard collet chuck is φ 6.0mm. Optional chucks vary from φ 1.0~ φ 8.0mm in 0.5mm steps, and φ 2.35(0.093"), φ 3.175(0.125") and φ 6.35(1/4") are also available.

Collet Cap : CHN-L

CHE : Standard collet chuck is φ 6.0mm.

Collet Cap : CHN-E

⚠ CAUTION :

Do not tighten collet cap too much without mounting a tool. The collet chuck will be crushed unnecessarily and separate from the collet cap. Then, the collet chuck will be difficult to remove from the spindle even when the collet cap is loosened.

7 Installation of spindle

When installing spindle on a holder, it is not recommendable to fix the spindle with a fastening bolt directly as shown in Fig. 6 because the sheath is deformed and creates rotating malfunction, heat generation, etc. Therefore, the installation as shown in Fig. 7 is recommended. In case it is impossible, install it as shown in Fig. 8.

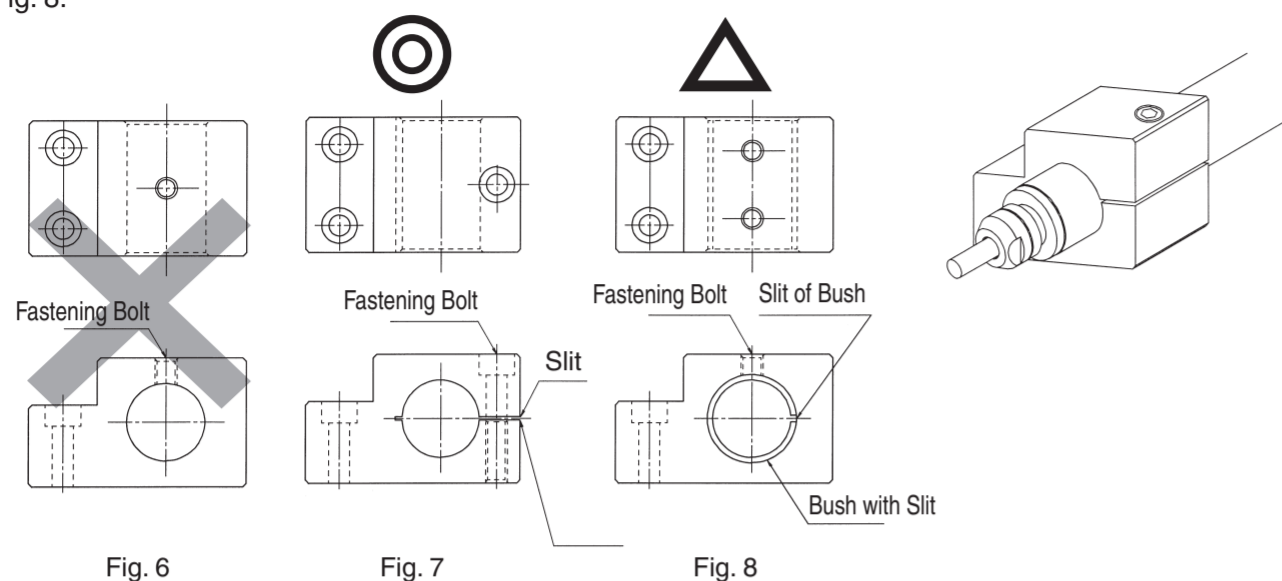

Fig. 6

Fig. 7

Fig. 8

8 How to supply air for debris protection

Use a standard screw driver to remove the screw and screw in a M5×0.8 thread quick disconnect fitting.

For spindles with 2 sealing screws you can use either location.

Supply clean, dry air between 0.1-0.3 MPa pressure.

(Please use caution as contaminated air will void warranty.)

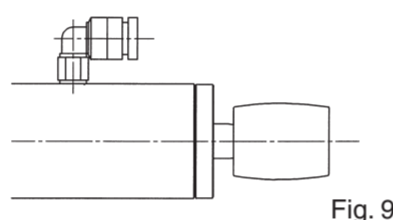

Fig. 9

9 Guidance for belt installation

For high speed operation increase belt tension to prevent slippage. During normal speed operation please reduce belt tension to increase rear bearing life.

If the motor pulley and spindle pulley are offset high speed rotation will produce excess vibration, causing heating build up and reduced life expectancy.

Please limit pulley center to center offset to less than 0.2mm.

Please follow the belt makers usage guidelines.

⚠ CAUTION :

Please cover all rotating parts to prevent injury.

10 Break-in procedures

PS Series spindles are high speed spindles, but the following break-in procedures are necessary.

During shipping and storage grease settling will occur. If the spindle is rotated at high speed quickly.

Uneven grease coverage will cause heat build up and bearing damage.

After initial fixturing please follow the break-in procedures to insure optimal life expectancy.

Please follow the break-in schedule in table 3.

Table-3 Break-in schedule

Step	1	2	3	4
Maximum allowable speed	30%	60%	80%	100%
Duration	15 minute	10 minute	10 minute	15 minute
Checkpoint	No abnormal noise	Spindle case should be less than 20°C. If case temperature exceeds 20°C, please shut down for 20 minutes. After 20 minute cool down period restart from step 1. If overheating continues please check spindle fixture.	Same as step 2.	Spindle outer case approximately 20°C.

11 Pulley removal procedures

Remove the pulley set screw, use a pulley removal tool to remove pulley. Please make a plate to insert between the pulley removal tool jaws and the pulley to aid in removal.

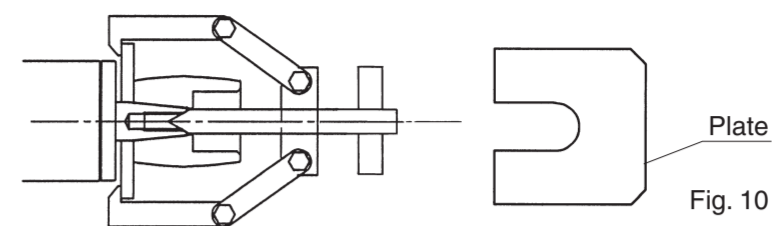

Fig. 10

12 Cautions when using grindstone

① Follow the recommended speed by the manufacturers when using drill, end mill, etc. Do not use them beyond the recommended speed because it becomes the cause of malfunction.

② Make sure the tool shank is clean. If foreign materials and any debris are left in the collet chuck, they will affect T.I.R specifications.

③ The recommendable peripheral speed of vitrified grindstone is within the range of 600 to 1,800m/min.

$$\text{Peripheral speed} = \frac{\pi \times D \times N}{1,000} \quad \begin{array}{l} D = \text{Grindstone Diameter} \\ N = \text{Grindstone rpm.} \end{array}$$

⚠ **Danger : Do not use beyond the peripheral speed of 2,000m/min. because it is dangerous.**

④ Mount a stemmed grindstone within 13mm of over-hanging mode. When mounting a stemmed grindstone longer than 13mm over-hanging mode, use it by slowing down the motor speed. (Fig. 11, Table-4)

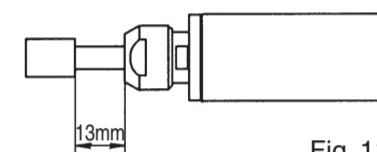

Fig. 11

Table-4

Over-hang(mm)	(min ⁻¹)
20	N×0.5
25	N×0.3
50	N×0.1

⑤ Do not use a poor quality and run-out grindstone with cracks and scratches.

⑥ Try to use a grindstone after dressing is made.

⑦ In case of grinding, the depth of cutting in one cycle is within 0.02mm.

The depth of cutting for single phase grinding is 0.01mm. After one cycle of grinding, repeat reciprocating motion few times and start next cycle of grinding.

⑧ Follow the recommended speed by the manufacturers when using drill, end mill, etc. Do not use them beyond the recommended speed because it becomes the cause of malfunction.

⑨ Make sure the tool shank is clean. If foreign materials and any debris are left in the collet chuck, they will affect T.I.R specifications.

⑩ Do not give an excessive shock and do not disassemble uselessly.

⑪ It is dangerous to run the run-out grindstone with cracks and bent shank in a high speed suddenly because the grindstone may be broken or explode and shank may be bent or broken. When rotating a new grindstone or grindstone without dressing is made, run it with a low air pressure and increase the speed gradually after confirming the safety.

13 Trouble shooting

Table-5

Phenomenon	Probable Cause	Corrective Action
Vibration of bur	Foreign substance sticking in side chuck or spindle	Clean chuck and spindle interior
	In correct chuck nut setting	Set chuck nut correctly
	Bearings worn out	Replace bearings at service center
Noise and abnormal vibration	Foreign substance sticking in bearings	Replace bearings at service center
	Bearings worn out	
	Tools bent	Replace with proper tool
	In correct installation of belt	Adjust or replace
No rotation	Bearings broken	Replace with new bearings at service center

※Specifications may be changed without notice.

NAKANISHI INC.
www.nakanishi-inc.com

700 Shimohinata Kanuma-shi
Tochigi 322-8666,
Japan

NSK Europe GmbH EC REP
www.nsk-europe.de

Elly-Beinhorn-Strasse 8
65760 Eschborn,
Germany

NSK America Corp
www.nskamericacorp.com

1800 Global Parkway
Hoffman Estates, IL 60192,
USA