

E2550 SYSTEM

OPERATION MANUAL

OM-K0340E Rev.A



contents

INSTRUCTIONS AND WARNING-Electric Devices.....	1	13. Connecting the Motor and Spindle.....	12
1. Cautions for handling and operation.....	2	14. Changing Cutting Tools.....	12
2. Features.....	3	15. Replacing the Collet.....	13
3. Specifications.....	3	16. Fixturing the Motor and Spindle.....	13
4. Torque/Output Characteristics.....	4	17. Operation Procedures.....	14
5. Nomenclature.....	5	18. External Input/Output Control Signal Specifications.....	16
6. Diagrams.....	7	19. Protect Function.....	22
7. Input Voltage Switching.....	8	20. Break-In Procedure.....	23
8. Changing Fuses.....	9	21. Cutting tool cautions.....	24
9. Power Cord Connection.....	9	22. Trouble Shooting.....	25
10. Bracket Installation.....	10	23. E2550 System Chart.....	26
11. Motor Cord Connection.....	10	24. Setting of Operating Parameters.....	26
12. Air Hose Connection.....	11		



IMPORTANT INSTRUCTIONS AND WARNING - Electric Devices

WARNING!

When using electric tools, basic safety precautions should always be followed to reduce the risk of fire, electrical shock and personal injury, including the following.

Read all these instructions before operating this product and save these instructions.

GROUNDING INSTRUCTIONS

1. In the event of a malfunction or breakdown, grounding provides a path of least resistance for electric current to reduce the risk of electric shock. This tool is equipped with an electric cord with a grounding conductor and a grounding plug. The plug must be plugged into a matching outlet that is properly installed and grounded in accordance with all local codes and ordinances.
2. Don't modify the plug provided - if it will not fit the outlet, have the proper outlet installed by a qualified electrician.
3. Improper connection of the grounding conductor can result in electric shock. The conductor with insulation having an outer surface that is green with or without yellow stripes is the grounding conductor. If repair or replacement of the electric cord or plug is necessary, do not connect the grounding conductor to a live terminal.
4. Check with a qualified electrician or service person if the grounding instructions are not completely understood, or if in doubt as to whether the tool is properly grounded.
5. Use only 3-wire extension cords that have 3-prong grounding plugs and 3-pole receptacles that accept the tool's plug.
6. Repair or replace damaged or worn cord immediately.
7. This tool is intended for use on a circuit that has an outlet that looks like the one illustrated in Sketch A in Figure (below) (115V). The tool has a grounding plug that looks like the plug illustrated in Sketch A in Figure (below).
8. For Installation in Machine Electrical Cabinet or when wiring directly to machine internal power terminal strip:
 - 1) Please refer to the pin diagram below for the proper wiring configuration. The plug shown is the female plug that attaches to the E2550 main power inlet.
 - 2) Make sure you test each individual wire to verify proper circuit prior to attaching any wire to the terminal block. Do not assume wire colors are the same for all power cords.
9. Install an over current protective device of maximum 10 Amp on the E2550 main power circuit.

Grounding Method

Power cord connector

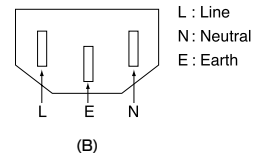
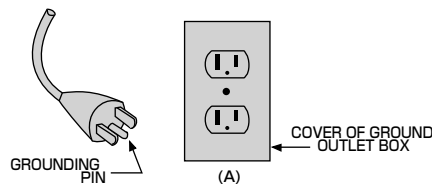

10. USE PROPER EXTENSION CORD. Make sure your extension cord is in good condition. When using an extension cord, be sure to use one heavy enough to carry the current your product will draw. An undersized cord will cause a drop the line voltage resulting in loss of power and overheating. Table (below) shows the correct size to use depending on cord length and nameplate ampere rating. If in doubt, use the next heavier gage. The smaller the gage number, the heavier the cord.

Minimum gage for cord

Ampere Rating		Volts	Total length of cord			
		120V 240V	7.5m(25ft.) 15m(50ft.)	15m(50ft.) 30m(100ft.)	30m(100ft.) 60m(200ft.)	45m(150ft.) 90m(300ft.)
More Than	Not More Than					
0	6		18	16	16	14
6	10		18	16	14	12
10	12		16	16	14	12
12	16		14	12	Not Recommended	



Only the applicable parts of the Table need to be included. For instance, a 120-volt product need include the 240-volt heading.

Thank you for purchasing the Ultra-Precision, High-Speed spindle system, E2550. The E2550 System was designed for use on CNC lathes, robots, NC lathes and special purpose machines. The motor, spindle and control unit are designed to work as an integrated system capable of 5,000-50,000min⁻¹. This system utilizes air to cool the motor and protect the spindle, please use an airline kit to ensure clean, dry, properly regulated air is supplied to the motor and spindle. The E2550 system is capable of being used with coolants and cutting lubricants. Please read this Operation Manual carefully prior to use.

1 Cautions for handling and operation

■ Read these cautions carefully and only use in the manner intended.

■ Safety instructions are intended to avoid potential hazards that could result in personal injury or damage to the device. Safety instructions are classified as follows in accordance with the seriousness of the risk.

Class	Degree of Risk
 WARNING	A hazard that could result in bodily injury or damage to the device if the safety instructions are not followed.
 CAUTION	A hazard that could result in light or moderate bodily injury or damage to the device if the safety instructions are not followed.

CAUTION

- ① The E2550 is not a hand tool. It is designed to be used on a NC lathe or special purpose machine.
- ② In the event of a malfunction or breakdown, grounding provides a path of least resistance for electric current, reducing the risk of electric shock. This system is equipped with an electric cord with a grounding conductor and a grounding plug. The plug must be plugged into a matching outlet that is properly installed and grounded in accordance with all local codes and ordinances.
- ③ Don't use in dangerous environments. Protect the control unit from moisture and other contaminants. Failure to protect the control unit can result in damage to internal components and injury to the operator.
- ④ Always wear safety glasses. Everyday eyeglasses only have impact resistant lenses, they are not safety glasses. Also use a dust or face mask whenever the motor is running.
- ⑤ Never touch the motor, spindle or cutting tools when the spindle is rotating.
- ⑥ Reduce the risk of unintentional starting. Make sure the power switch is in the Off position before connecting the control unit or plugging the system in.

WARNING

- ① Motor cooling and spindle purge air is required to operate the system. Air hose must be connected to the Air In Joint on the front of the control unit. Between 0.15-0.25MPa air must be supplied.
- ② Do not disassemble, modify or attempt to repair the unit or motor as it will damage internal components and there are no user serviceable parts.
- ③ When errors occur and error lamp flashes, check and correct the cause of the malfunction before continuing use. Failure to correct the problem will result in damage to the unit and motor.
- ④ When the WARNING Lamp on the control unit lights conditions exist that could result in dangerous operation. Check operating conditions and continue use only after correcting the problem.
- ⑤ Do not hit, drop or subject motor, spindle or control unit to shock as this will cause damage to internal components and result in malfunctions.
- ⑥ Check the tool shank and collet prior to use to ensure they are clean and free of burrs. The introduction of foreign particles or metal chips into the collet or spindle can cause damage and loss of precision.
- ⑦ Make sure that the collet chuck is firmly tightened prior to rotating the spindle. If the collet chuck and chuck not are not firmly tightened the tool may be ejected during rotation resulting in injury.
- ⑧ The electric motor and spindle require air for cooling and protection; ensure that this supply is clean, dry air. Introduction of dust, moisture or other contaminants into the motor and spindle will cause damage to internal components.

- ⑨ Please refer to the Torque/Output characteristics to ensure you are operating the spindle system within its normal working envelope.
- ⑩ The Check function rotates the motor at 500min^{-1} , this function is strictly for the purpose of centering the spindle and tool it is not intended to be used for cutting or grinding.
- ⑪ Spindle, motor and control unit are designed to be used as an integrated system, do not attempt to use parts separately, this could cause damage to internal components and injury.
- ⑫ Do not place anything on top of the control unit or block cooling vents.
- ⑬ Do not install system next to RF noise sources malfunctions can occur.
- ⑭ If smoke, noise or strange odors emanate from the unit or motors immediately turn off the power switch, disconnect and take to NAKANISHI distributor for repair.

2 Features

- ① The E2550 system is designed to be mounted in a CNC lathe, robot, NC lathe or special purpose machine for drilling, milling, slitting, grinding or other similar application.
- ② A high-speed brushless motor is used to achieve a maximum speed of $50,000\text{min}^{-1}$ and eliminate the nuisance of brush maintenance.
- ③ Speed control and protection functions utilize a high performance microprocessor.
- ④ Automatic control and monitoring of spindle functions are possible.
- ⑤ Up to 2 motors can be controlled sequentially from the control unit enabling multi-spindle applications.
- ⑥ Wide speed range, $5,000\text{--}50,000\text{min}^{-1}$ makes high precision machining possible.
- ⑦ Compact control unit design allows easy installation in space restricted machines. Connectors and control panel are front mounted for easy access.
- ⑧ Control Unit is capable of being connected to 120V or 230V power sources. The control unit incorporates a voltage selection switch; make sure this switch is set to the proper position for the voltage being used.
- ⑨ The motor/spindle housing is made of Stainless Steel (SUS-416), precision ground to 25mm making the motor/spindle very versatile and easy to mount on NC or special purpose machines.
- ⑩ Two types of control units are available. Standard type NE145 and NE145-OP1 which conforms to European standards for safe, automatic machine operation.
- ⑪ Wide range of collet chucks available.
- ⑫ A wide variety of spindles and speed reducers is available making this system highly flexible.

3 Specifications

① Control Unit

Model		NE145	NE145-OP1 ※Note2
Input		AC115V/230V, 50/60Hz, 1PHASE, 1.2A/0.6A	
Output		AC27V, 3PHASE, 1.5A	
Operating Temperature		0-40°C	
Ambient Humidity		MAX. 85%	
Over Voltage Category		II	
Pollution Degree		2	
Speed Range		5,000-50,000 min^{-1} (500 min^{-1} for centering only)	
Control Signal	Input ※Note1	Transistor Activation Connections: 5 Analog Connections: 2	Transistor Activation Connections: 6 Analog Connections: 2
	Output ※Note1	Transistor Activation Connections: 9 Analog Output Connections: 3	Transistor Activation Connections: 9 Relay Contact Connections: 2 Analog Output Connections: 3
Protection Circuits		Over-Voltage, Over-Current, Over Load, Sensor Malfunction, Overheat, Brake Malfunction, Spindle Lock, Low Air Pressure, Start-Up Error, Over-Speed	Over-Voltage, Over-Current, Over Load, Sensor Malfunction, Overheat, Brake Malfunction, Spindle Lock, Low Air Pressure, Start-Up Error, Over-Speed, Emergency Stop Circuit
Weight		3.6kg	
Dimensions		W108mm × D156mm × H175mm	

※Note1 : Protectively Separated

※Note2 <NE145-OP1 Features>

- The installed Safety Relay is designed to comply with EN standards, 'a' contacts switch the Motor Power Line and 'b' contacts switch the external outputs to the machining center's controller.
 - The Safety Relay utilizes Normally Open contacts. The Emergency Stop Signal lines must be supplied with power to hold the Safety Relay contacts closed and allow the control unit to supply power to the motor. Any system errors, trouble with the machining center or the connections between the E2550 control unit and the machining center's controller will cause the relay contacts to open and the E2550 motor to stop.
 - The Emergency Stop Signal Input can be connected to any and all portions of the machine's safety systems to stop the E2550 motor any time that of stoppage of the spindle and motor is required.
 - The 'b' contact outputs can be used to detect an open circuit on the motor line and integrated with the machines safety systems to stop the machine in case of trouble.
- If the 'a' contacts of the Safety Relay are welded together by an over load or short circuit the 'b' contacts' separation is maintained at more than 0.5mm spacing by the relay's spring release mechanism.

② Motor

Model	EM25N-5000-J4
Speed Range	5,000-50,000min ⁻¹
Peak Power Output	125W
Continuous Power Output	40W
Cooling Air Pressure	0.15-0.25MPa
Cooling Air Consumption	35Nℓ/min at 0.25MPa
Weight	250g (w/o motor cord)
Dimensions	φ 25mm × 111.4mm

③ Spindle

Model	NR-2551, NR-H2551
Maximum Motor Speed	50,000min ⁻¹
Spindle Accuracy	Less than 1 μm
Standard Collet Chuck(CHK-3.0)or(CHK-3.175)	φ 3.0mm or φ 3.175mm
Weight	253g (NR-2551) 261g (NR-H2551)
Outside Diameter	φ 25mm(NR-2551) · φ 25.4mm(NR-H2551)

<Options>

Collet Chuck (CHK-□□)	φ 0.5mm-6.0mm in 0.1mm increments (φ 2.35mm, φ 3.175mm, φ 6.35mm)
Chuck Nut	K-265
Metal Saw Axis (KCH-03)	For φ 6 I.D. × φ 30mm O.D. metal saw. φ 4.76mm φ 5mm I.D, φ 6.35mm I.D, & φ 8mm I.D. axis (arbor) are also available.
Drill Chuck Axis (DCH-J0K)	For Jacob's Taper No. 0
Grindstone Axis (AGM-03)	For inner diameter φ 5mm grinders

Standard Accessories

- Power Cord · Air Hose with Filter · Connector Cap · Connector Cover A · Connector Cover B
- Air Plug · Bracket (2 pcs.) · Nylon Tension Relief · Screw (7 pcs.) · Operation Manual

4 Torque/Output Characteristics

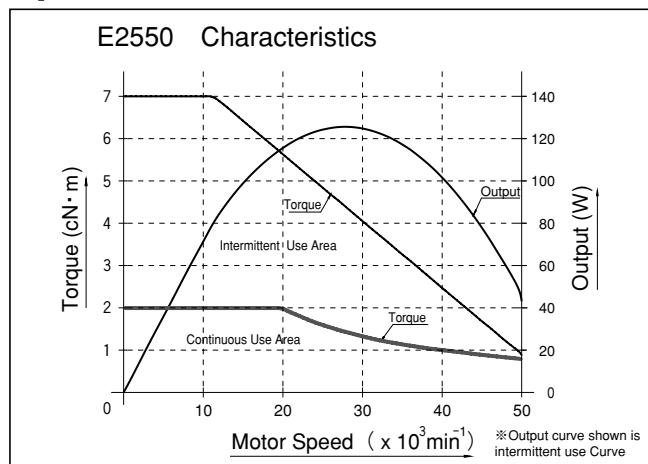

5 Nomenclature

(1) System

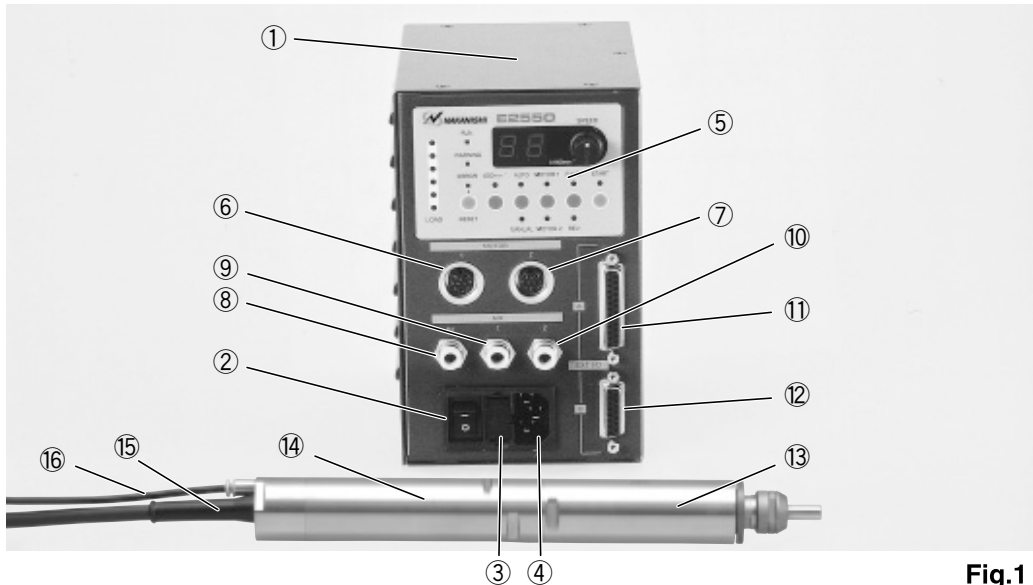

Fig.1

① Unit (NE145 Shown)

② Power Switch

③ Fuse Holder

④ Main Power Inlet

⑤ Control Panel

⑥ Motor Connector #1

⑦ Motor Connector #2

If this position is not being used, please install 'connector cap' to prevent contamination.

⑧ Air Input Joint

Supply clean, dry, regulated air for motor cooling. Regulate air to between 0.15MPa-0.25MPa. Air must be supplied to operate the system.

⑨ Cooling air output joint for motor #1

Connect 4mm air hose from motor to output joint using 4mm to 6mm adaptor.

If this position is not being used, please install the 'air plug' to prevent contamination.

⑩ Cooling air output joint for motor #2

Connect 4mm air hose from motor to output joint 4mm to 6mm adaptor.

If this position is not being used, please install the 'air plug' to prevent contamination.

⑪ Input/Output Connector A

Connector for automatic control and monitoring of motor/spindle system.

When not in use please install the connector cover to prevent damage or contamination of connector or pins.

⑫ Input/Output Connector B

Connector for automatic monitoring of emergency conditions. The pin configurations of this connector are different on the NE145 and NE145-OP1. Please refer to page 19 for a complete description of the pin input and output signals. When not in use please install the connector cover to prevent damage or contamination of connector or pins.

⑬ Spindle

⑭ Motor

⑮ Motor Cord

⑯ Motor cooling air hose.

For the motor connected to connector ⑥ connect the cooling air hose to connector ⑨. For the motor connected to connector ⑦ connect the cooling air hose to connector ⑩. Connect the 4m long 4mm air hose to the cooling air output joint using the 4mm to 6mm adaptor.

(2) Control Panel

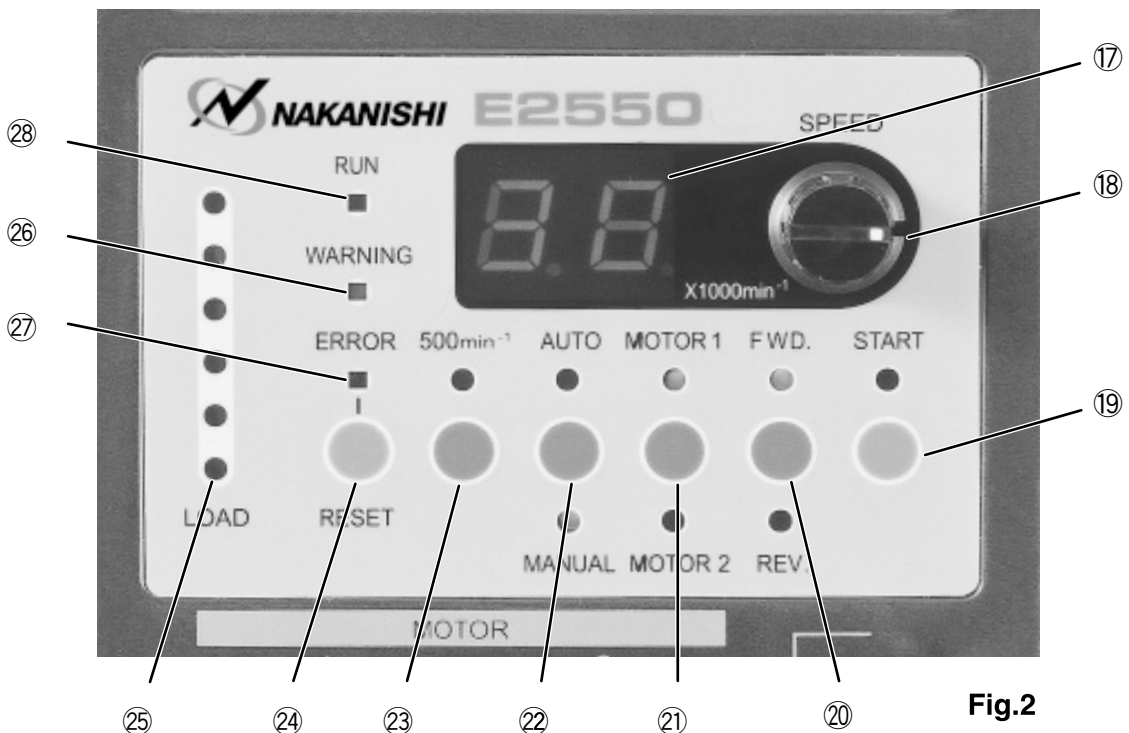

Fig.2

①⑦ Digital Speed Indicator (Speed)

Preset Speed, Actual Speed, Warning and Error Codes are displayed to 2 digits. When the motor is stopped the Preset Speed is displayed, when the motor is rotating the actual speed is displayed. The display also displays the error codes when an error has occurred.

①⑧ Speed adjustment knob

Steplessly adjustable speed control. Rotating the knob clockwise will increase rotating speed. Speed is adjustable from 5,000-50,000min⁻¹.

①⑨ Start Switch

Starts and stops motor rotation.

①⑩ Forward/Reverse Switch

Right hand rotation(FWD) and left hand rotation(REV) are as viewed with the cutting tool facing the operator. With the cutting tool facing the operator right hand rotation(FWD) will be clockwise rotation.

①⑪ Motor Selection Switch

Selects the Motor to be controlled 1 or 2.

①⑫ Controller Switch (Auto-Manual)

This switch selects motor/spindle control from the Control Panel or from an external source.

- MANUAL : Control Panel
- AUTO : External control through the input/output connector.

①⑬ Centering Mode Switch (500min⁻¹)

This switch activates the centering mode, which maintains a constant 500min⁻¹ spindle speed for centering the tool.

①⑭ Reset Switch (Reset)

This switch resets and allows restarting of the motor/spindle after an error has been corrected. Some error codes will not allow the unit to be reset until after the power switch has been turned off.

①⑮ Load Monitor LED (Load)

The motor/spindle load is displayed by 6 LED's (3 Green, 2 Yellow and 1 Red). Continuous operation is possible with up to all 3 green LED's lit. If one of the yellow LED's is lit the motor/spindle can only be run for a short time. Please refer to Section 19 part 4 of this manual for allowable duration of high load operation.

When any of the yellow or red LEDs are lit the warning LED (Warning) ⑳ will flash, if this condition is continued beyond the allowable interval the error LED (Error) ㉑ will flash and the motor/spindle will be shut down.

㉒ **WARNING LED (WARNING)**

The operating and working conditions of the system are constantly monitored and the warning LED blinks when a hazardous condition has been detected. When a hazardous condition is detected the warning LED blinks and the Digital Speed

Indicator ㉓ alternates between the warning code and the actual or preset speed, depending on whether or not the motor/spindle is rotating.

㉔ **Error LED (Error)**

When a serious problem with the system is detected this LED blinks, the motor/spindle is shut down and the Digital Speed Indicator ㉓ displays the error code.

㉕ **Rotating LED (RUN)**

When the motor is rotating this LED will flash.

6 Diagrams

(1) Motor/Spindle Diagram

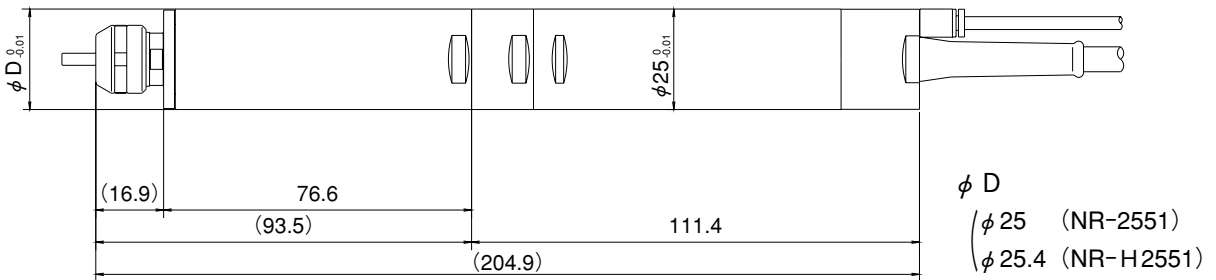

Fig.3

(2) Control Unit Diagram

Brackets installed on the bottom

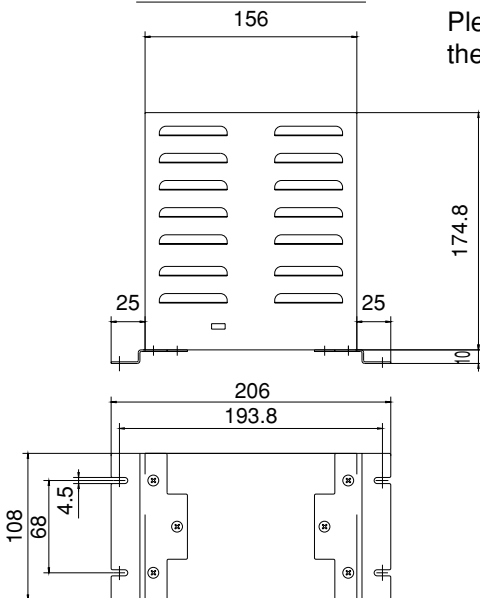

Fig.4

Mounting brackets are provided for mounting the control unit. The control unit can be mounted either vertically or horizontally. Please review the mounting cautions on P10 ㉖ prior to mounting the control unit.

Brackets installed on the rear

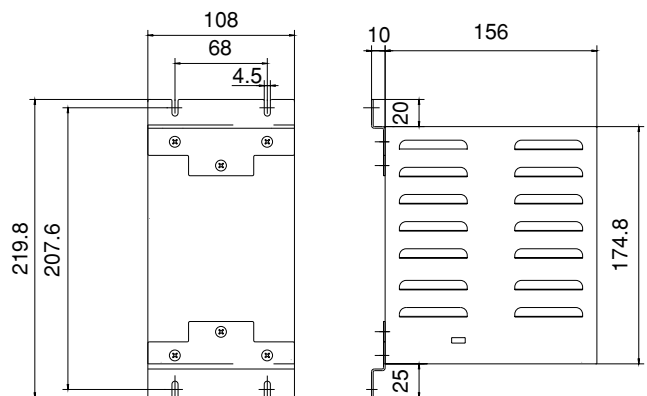

Fig.5

7 Input Voltage Switching

- The Control Unit is compatible with 120V-230V main supply voltage and is equipped with a switch for voltage selection.

WARNING

Improper voltage settings can result in damage to internal components and injury, please use care in selecting the voltage setting and ensure that you are connecting to the proper outlet.

- Before connecting the control unit to the power supply, please check the main fuses and verify that they are compatible with the voltage being supplied. Please refer to the flow chart below for voltage switching procedures.

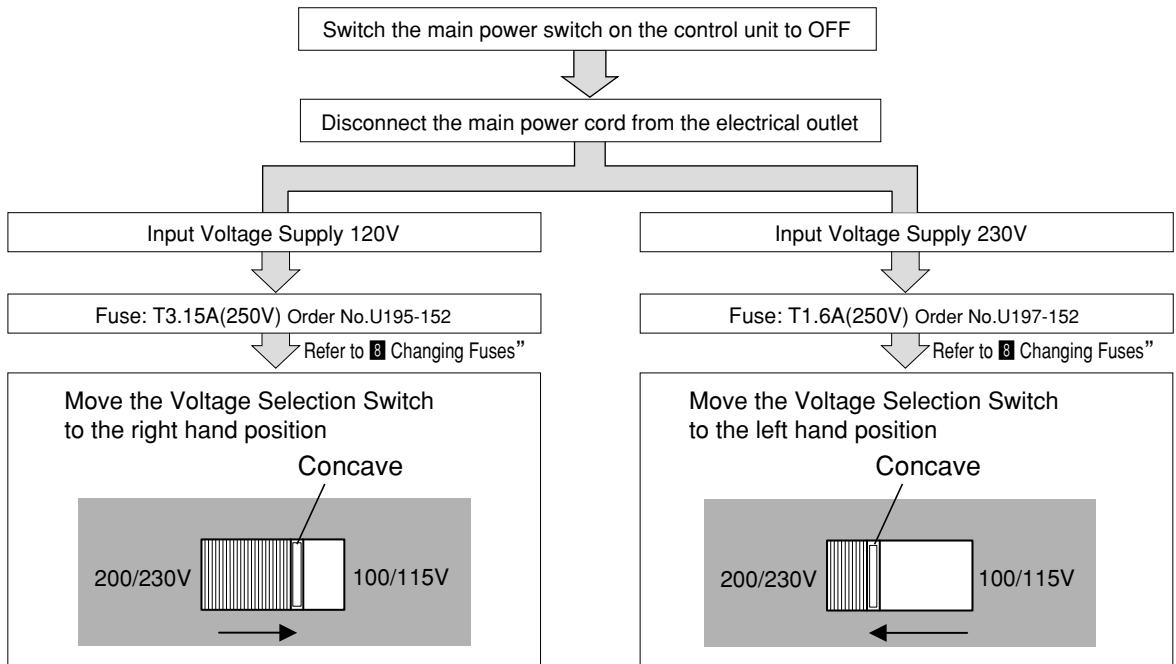

※Switch Location Diagram

- The voltage selection switch is located on the lower, rear portion of the left side panel.
- Please use a standard screw driver to change the selector switch position



Fig.6

CAUTION

Always disconnect the main power cord for the control unit and switch the main power switch OFF before attempting to change the voltage selection. Failure to follow this caution can result in internal arcing, causing damage to internal components and serious injury.
ONLY USE GROUNDED PLUGS

8 Changing Fuses



CAUTION

- Before removing fuse make sure that the main power switch is in the off position and the power cord is disconnected from the power supply.
- Make sure and use only the properly rated and type of fuse.
- Failure to use the proper type and rated fuse will result in fire, injury, electric shock and/or product damage.

- Push on the clips on the top and bottom of the fuse holder and remove the fuse holder and fuses.
- Remove the bad fuse or fuses and replace with the proper type and rating of fuse as listed below and determined by the input voltage being used.

There are two different types of fuses depending on the input power source voltage.

115V T 3.15 A (250V) U195-152

230V T 1.6 A (250V) U197-152

- Replace the fuse holder containing the fuses into the fuse inlet box and make sure it snaps in place.



cap

Fig.7

9 Power Cord Connection

- Insert the female plug into the main power inlet box ④ in the front of the unit.
- A screw hole is provided on the lower, right side of the control unit for attaching the tension relief. Use the provided Nylon Tension Relief to attach the power cord to the side of the control unit.

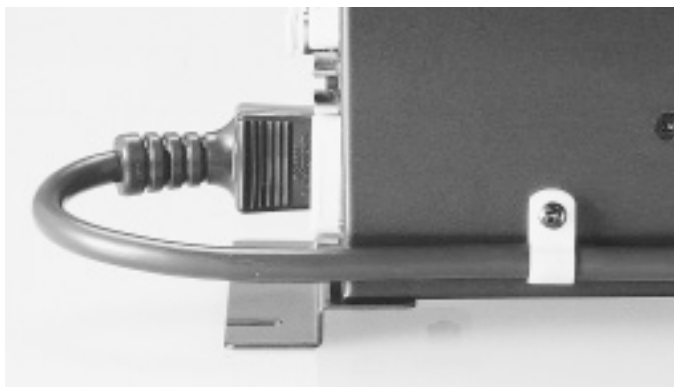

Fig.8



WARNING

Only use grounded power sources. Failure to properly ground the unit may result in electric shock, injury, fire and/or damage to the system components.

10 Bracket Installation

- Two mounting brackets are provided with the system.
- The brackets can be installed on the bottom or on the back of the control unit.
- After installing the brackets you can use the screw cutouts to mount the control unit.

① Bottom Installation

- Attach the brackets using the six holes on the bottom of the unit using the provided screws.



Fig.9

② Back Side Installation

- Attach the brackets using the six holes on the back of the unit using the provided screws.

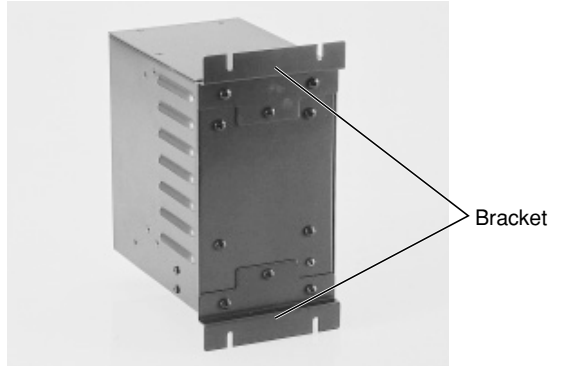

Fig.10

! CAUTION

- **Never install the unit in an inclined or inverted position. This manner of installation will cause heat buildup, or damage to the control unit.**
- **Never install the unit in such a manner as to block the air vents on the side of the control unit. This manner of installation will cause heat buildup and damage to the internal components of the control unit.**

③ Proper Clearance

When installing 2 or more control units in the machine cabinet make sure to check that each single control unit has the proper clearance on all sides.

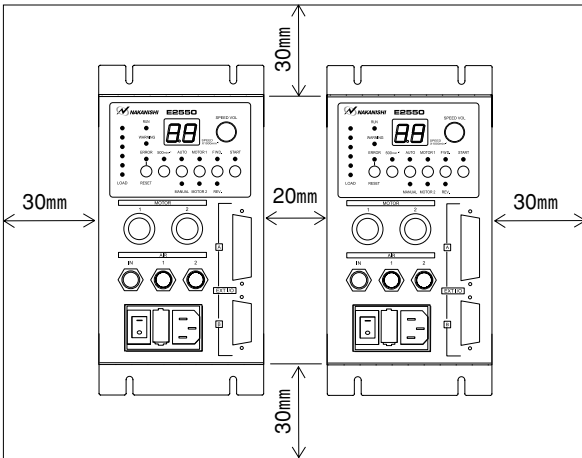

Fig.11

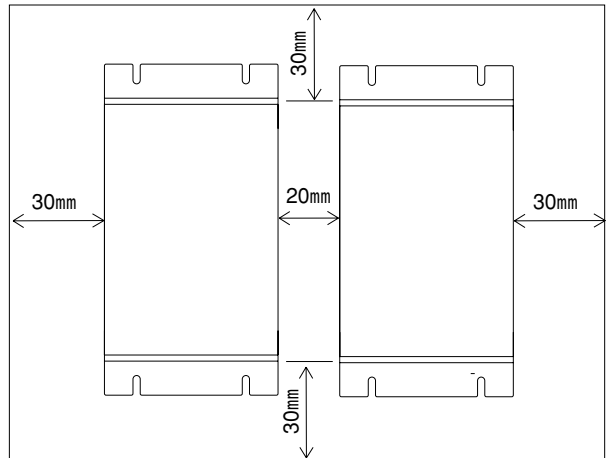

Fig.12

11 Motor Cord Connection

- Align the guide pin A on the motor plug with the key way B on the motor socket on the front of the control unit.
- Screw in the coupling nut C of the motor plug to the motor socket D on the front of the control unit.
- If you are using only one motor, attach the plug cap on the unused motor socket on the front of the control unit.

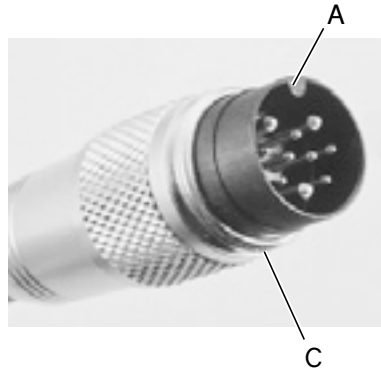

Fig.13

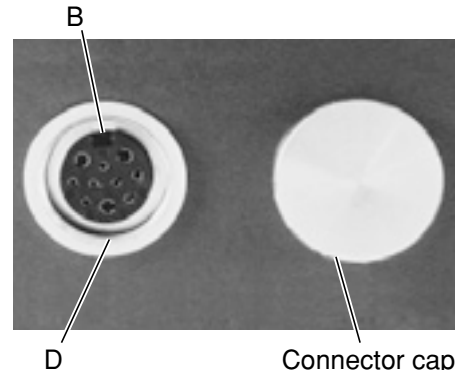

Fig.14

12 Air Hose Connection

- Insert the provided ϕ 6mm filtered air hose from the AL-0201 air line kit into the inlet joint ⑧ on the front of the control unit. (If you are not using the AL-0201 air line kit, make sure that the incoming air supply is dry, clean air.)
- Insert one end of the provided ϕ 4mm cooling air hose into the back of the motor.
- Insert the other end of the ϕ 4mm cooling air hose into the output joint ⑨: motor #1 ⑩: motor #2 on the front of the control unit using the provided 6mm to 4mm adaptor.
- Regulate air pressure between 0.15-0.25 MPa.

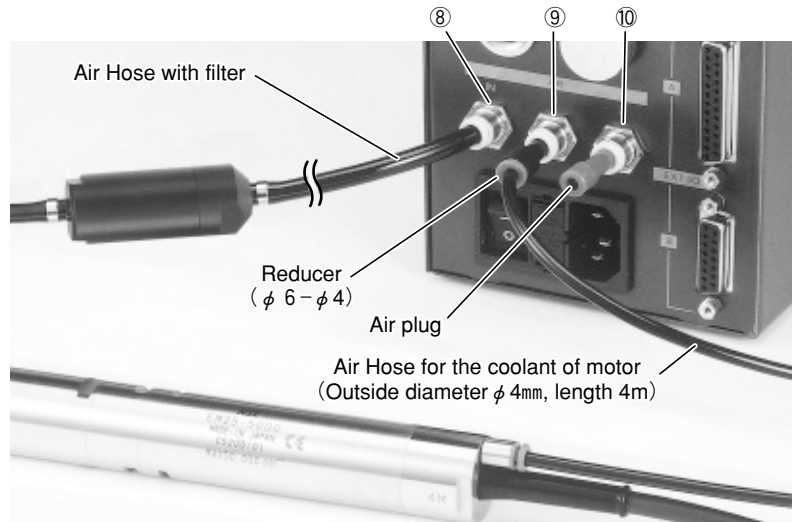

Fig.15

⚠ CAUTION

- If you are using only one motor, please insert the air plug into the unused output joint on the front of the control unit. If you don't attach the air plug, air will free flow from the unused air output joint.
- The cooling air provides two functions, to cool the electric motor and to protect the spindle from contaminants. If the main power switch ② is in the OFF position do not subject the spindle to direct coolant spray or use in dusty areas.
- Regulate the air supply between 0.15-0.25MPa. If the air pressure is too low the control unit will not operate.
- Do not bend the air hose in any sharp bends or pull on the hose, this can cause the hose to break, cut off the air supply or weaken the hose over time resulting in deterioration of the motor and spindle.
- The system can be set to operate without cooling air. Please see parameter setting P8 to set this option. Maximum speed is 30,000min⁻¹ when not using cooling air.
Note : It is not recommended to use the system in this manner for general machining. This setting is only for light cutting and not for use with coolants.

13 Connecting the Motor and Spindle

Align the threads at the front end of the motor and the rear end of the spindle and turn the spindle clockwise. If the motor's drive shaft and the spindle's drive dog do not align properly, you will only be able to turn the spindle about 2 turns. **DO NOT FORCE**. Turn the spindle back, counterclockwise, slightly and rotate the spindle by hand to engage the drive assemblies and then screw them together tightly and fasten with the provided wrenches.

⚠ CAUTION

Make sure your hands and all interlocking parts of the spindle and motor are clean before connecting the motor to the spindle to prevent contaminants from entering the motor or spindle.

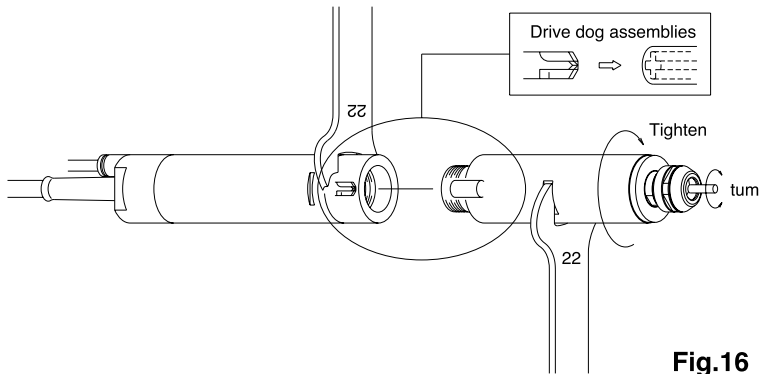

Fig.16

14 Changing Cutting Tools

- ① Set the provided 12mm wrench on the spindle.
- ② Place the provided 14mm wrench on the chuck nut and turn it counterclockwise to loosen the collet and remove the cutting tool. (The first turn will loosen the chuck nut, but the tool will not release and turning will become stiff. Keep turning through the stiffness and the collet will open.)
- ③ Insert the new tool and tighten the collet by turning clockwise.

⚠ CAUTION

Never install a collet into the spindle quill without first assembling it in the chuck nut. Do not tighten the collet without mounting a cutting tool or test bar as this will result in damage to the collet, spindle and collet nut and make it impossible to remove the collet.

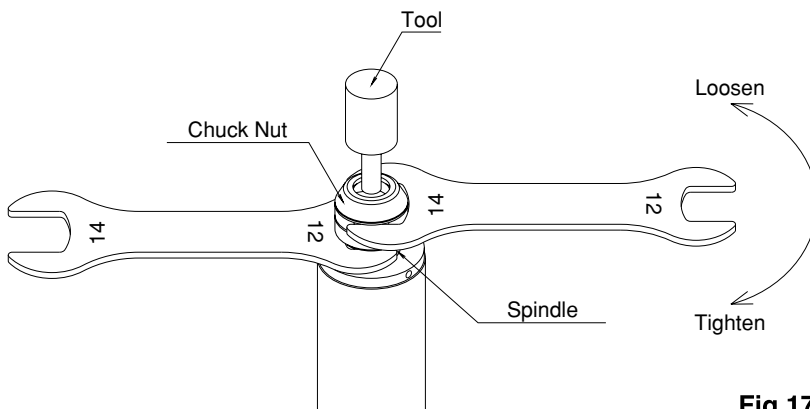
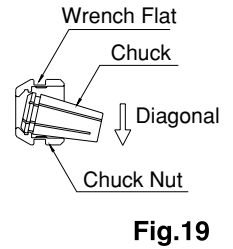
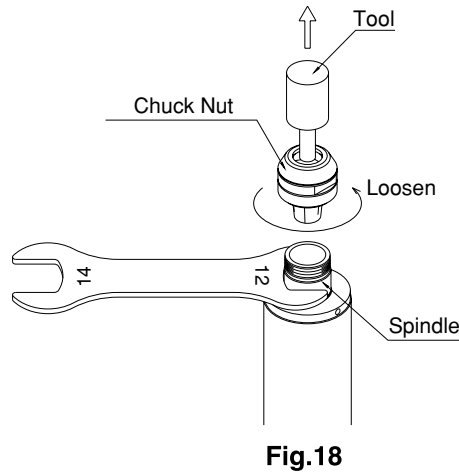

Fig.17

15 Replacing the Collet

- ① Remove the cutting tool according to the "Changing Cutting Tools" procedure above and remove chuck nut assembly. (Fig.18)
- ② The collet and chuck nut are held together by a groove in the collet and a flange in the chuck nut. To remove the collet hold the chuck nut in one hand and push diagonally down on the collet. The collet should pop out. (Fig.18)
- ③ Install the new collet in the chuck nut by positioning the collet in the chuck nut and pressing down on a flat surface. (Fig.19)



16 Fixturing the Motor and Spindle

The installation shown in **Fig.20** is the recommended fixturing method. If this is not possible, install as shown in **Fig.21**. Do not use set screws directly in contact with the motor or spindle body as shown in **Fig.22**, this will result in damage to the housing and internal components. When mounting the spindle take care not to fixture over the bearings as this will result in bearing damage. Refer to **Fig.23** it shows clamping area.

⚠ CAUTION

When installing a motor/spindle to a fixed base, make sure the fixed base is grounded in order to avoid the risk of an electric shock.

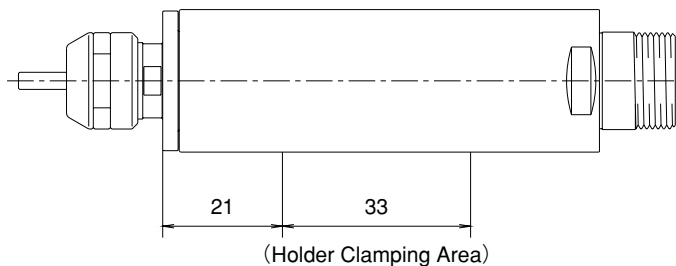
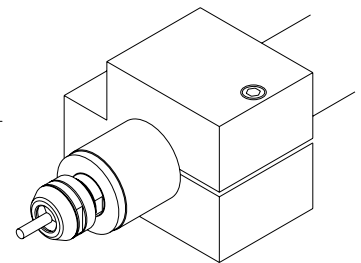
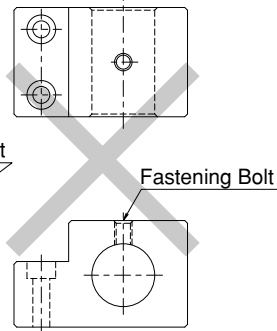
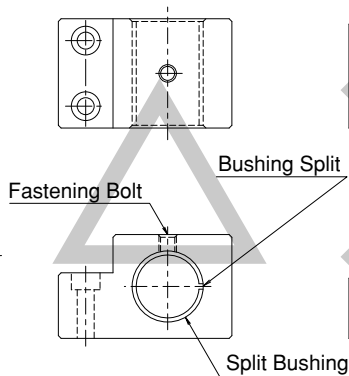
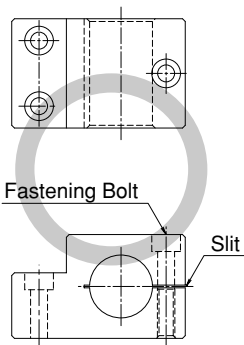

17 Operation Procedures

(1) Selecting control mode

- Using the control switch (22 in Fig.24) you can select between Manual (Front Panel Control) or Auto External Signal Source can be used to control “Motor Start/Stop” , “Rotational Direction” , “Motor Selection” and “500min⁻¹ centering rotation” .

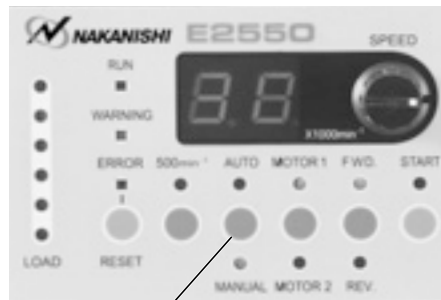

22 Control Switch

Fig.24

- Manual Mode-Front Panel Operation.
- Auto Mode-Control by External Signal Source.

(2) Selection of: Motor # 1 or #2, Rotation Direction, 500min⁻¹ centering rotation, Motor Start/Stop.

① Manual Control Mode

- Select Motor #1 or #2 Push the motor select switch 21



CAUTION

Motor #1 and Motor #2 cannot be run at the same time.

- Set rotation direction Push the rotational direction switch 20

- Select 500min⁻¹ centering rotation

Push the 500min⁻¹ switch 23

(Never use 500min⁻¹ rotation for cutting, this mode is only for centering on a machining center)

- Motor Start/Stop Push Start switch 19, the 'Start' LED will light and the spindle will rotate. Push the switch again to stop the spindle the LED will turn off and the spindle will stop rotating.



23 500min⁻¹ Switch

21 Motor Select Switch

Fig.25

② Auto Control Mode

Use the Input/Output Connector A ① to input control signals to the unit.

- Select motor #1 or #2 Input the motor select signal to Pin No. 15:SEL
Selecting Motor #1, OFF 'Open'(Motor 1 LED will light)
Selecting Motor #2, ON 'Closed'(Motor 2 LED will light)
- Set motor rotating direction Input the motor rotating direction signal to Pin No. 2:DIR_IN
Right hand rotation is OFF 'Open'("F.W.D" LED will light)
Left hand rotation is ON 'Closed'("R.E.V" LED will light)
- Set 500min⁻¹ rotation Input the centering rotation signal to Pin No.16:500min⁻¹
500min⁻¹ LED will light
Never use 500min⁻¹ centering rotation for cutting
- Motor Start/Stop Input the motor start signal to Pin No. 14:START
Motor rotating is ON 'Closed'(START LED will light)
Motor stopped is OFF 'Open'(Start LED is Off)
If the motor start signal is ON 'Closed' and the power switch is turned on or the control mode is changed from MANUAL to AUTO error code 'EA' will be displayed. This is a safety feature to prevent unintended rotation.

(3) Setting Motor Speed

① Control Mode is set to "MANUAL"

Set the speed by rotating the SPEED Knob ⑱. Clockwise increases speed, counterclockwise decreases speed.



Fig.26

- Motor Speed Range is 5,000-50,000min⁻¹.
If the air pressure is too low the control unit will not operate.
- The motor speed is displayed in 1,000min⁻¹. "50" equals 50,000min⁻¹
- If you are using Motor #1 select "MOTOR1" using the Motor Select Switch. If you are using Motor #2 select "MOTOR2" using the Motor Select Switch.

⚠ CAUTION

By changing the Operating Parameters (24 the setting of parameters) , you can set the following operating parameters:

- Motor Speed · Maximum Motor Speed · AUTO MODE Motor Speed
- Motor Start Command Signal Method · Air Input monitoring override

If you change any of the default parameters, you need to set the motor speed as well.

②Control Mode is set to “AUTO”

Input External Signal Source to Input/Output Connector A ①

- Motor #1 rotation speed is set by voltage input to Motor Speed Control Signal #1 (Pin No.23:VR1)
- Motor #2 rotation speed is set by voltage input to Motor Speed Control Signal #2 (Pin No.3:VR2)
- 0V DC equals 5,000 min⁻¹ and more than 8V DC equals 50,000 min⁻¹. If the air pressure is too low the control unit will not operate.
- The motor speed is displayed in 1,000 min⁻¹. “50” equals 50,000 min⁻¹.

(4) Setting other Motor Speed Parameters

The following Motor Speed Parameters can also be preset.

- Fix the motor speed of motor #1 and #2.
- Set the maximum motor speed of motor #1 and #2.
- When using AUTO control mode the motor speed of motor #1 and motor #2 can be set either electronically or by the potentiometer on the front panel.
- Motor Start Command Signal Method
- Air Input monitoring override

If an error occurs an error signal is output to the Input/Output Connectors. The default setting is ON('Closed') and OFF('Open'), this setting can be reversed if desired. Please refer to the Setting of Parameters section of this manual for details on reversing these signals.

18 External Input/Output Control Signal Specifications

(1) Input/Output Connector A

①Outside INPUT-OUTPUT Connector Signal Detail

Pin No.	Pin Name	Description	Input / Output	Signal	Function
1	COM(+)	24VDC Power Source for External Control Inputs	Input	+24V or 0V DC	Power Source to be used for External Inputs. +24V or 0V DC (*2).
2	DIR_IN	Rotation directed signal	Input	OFF(Open):FWD ON(Closed):REV	Controls the direction of rotation of the motor.
3	VR2	Motor Speed Control Signal #2	Input	DC0-10V 0V:5,000min ⁻¹ 8V:50,000min ⁻¹	Sets rotating speed of Motor #2.
4	RESET	Error Release Signal	Input	ON(Closed) OFF(Open)	Error code can be released and the system restarted by switching this signal OFF and ON.
5	—	Not Used	—		Not Used
6	RUN	Rotating Signal	Output	ON(Closed):MotorRotating OFF(Open):Motor Stopped	Voltage output shows that the motor is rotating.
7	DIR_OUT	Rotating Direction Signal	Output	OFF(Open):FWD ON(Closed):REV	Voltage output shows the direction the motor is rotating.
8	ERR	Error Signal	Output	ON(Closed):Normal OFF(Open):Error	Error has occurred. (*1). Error Code is displayed on the Digital Speed Display.
9	—	Not Used	—		Not Used.
10	GND	Power Source GND	Output	Internal GND	Internal Ground (*2).
11	VCC	10VDC Power Source for External Control Inputs	Output	+10VDC	Power Source for External Speed Control Signal (VR1 & VR2).
12	MOTOR_I	Motor Current Monitor	Output	0-10VDC 0V: 0A 10V:20A	Voltage Output shows the motor current consumption. Output voltage is proportional to the motor current consumption.
13	GND	Power Source GND	Output	Internal GND	Internal Ground.
14	START	Rotate Command Signal	Input	ON(Closed):Rotation OFF(Open):Stop	Starts and Stops motor rotation.
15	SEL	Motor Select signal	Input	OFF(Open):Motor #1 ON(Closed):Motor #2	Selects the motor to be used.

16	500min ⁻¹	Rotates Motor at "Centering" Speed	Input	ON(Closed):500min ⁻¹ OFF(Open):Normal Operation	Maintains constant 500min ⁻¹ motor speed for centering
17	OP_IN	Reserved Signal	—	—	Reserved Signal DO NOT USE
18	COM(-)	External Power Source GND	Input	External Ground	Connect to GND of external Power Source
19	PULSE	Rotating Pulse	Output	1 pulse/ rotation	1 revolution of the motor generates one pulse. Duty 50%
20	WARNING	WARNING Signal	Output	OFF(Open):Normal Operation ON(Closed):WARNING	This output shows a WARNING has occurred. The WARNING Code is shown on the Digital Speed Indicator
21	COIN	Speed Achievement Signal	Output	ON(Closed):Ordered Speed Achieved OFF(Open): Ordered Speed Not Achieved	Voltage output shows that the motor has achieved more than 90% of the set speed.
22	—	Not Used	—	—	Not Used
23	VR1	Motor Speed Control Signal #1	Input	0-10VDC 0V:5,000min ⁻¹ 8V:50,000min ⁻¹	Sets rotating speed of Motor #1 Voltage Output is proportional to the motor speed.
24	LOAD	Torque Load Monitor	Output	0-10VDC 0V: 0% 10V: 200%	Voltage output shows the torque being applied to the motor. Load monitor voltage x20 equals the torque load %. 20V=Load%
25	SPEED_V	Rotating Speed Monitor Voltage	Output	0-10VDC 1V:10,000min ⁻¹ 5V:50,000min ⁻¹	Voltage Output is proportional to the motor speed

※1 The error signal output can be reversed. Please refer to the setting of parameters section of this manual.

※2

⚠ CAUTION

- If you input 0V DO NOT connect PIN1 to PIN 10 or 13(Internal Ground)
- DO NOT connect PIN10 or 13(Internal Ground) to PIN18(External Power Source Ground)

② Input/Output Signals

● Input Signal

There are 5 kinds of input signals: rotation command, rotation direction, motor selection, 500min⁻¹ speed command. These signals are +24VDC signals from an external signal source.

Please use a separate power source that is capable of supplying 24VDC±10%, 25mA (5mA/circuit). Refer to Figures below for connections.

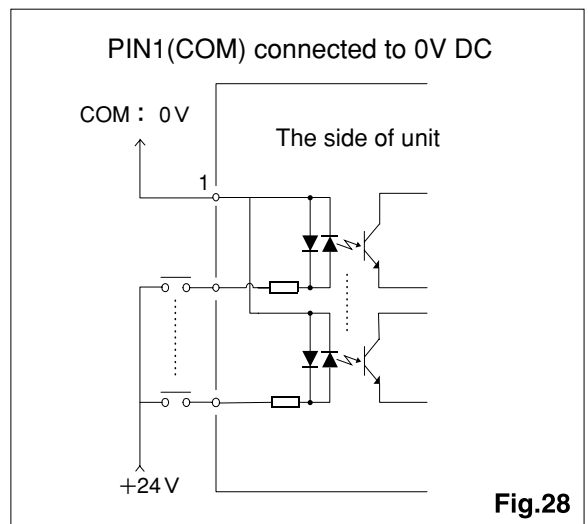
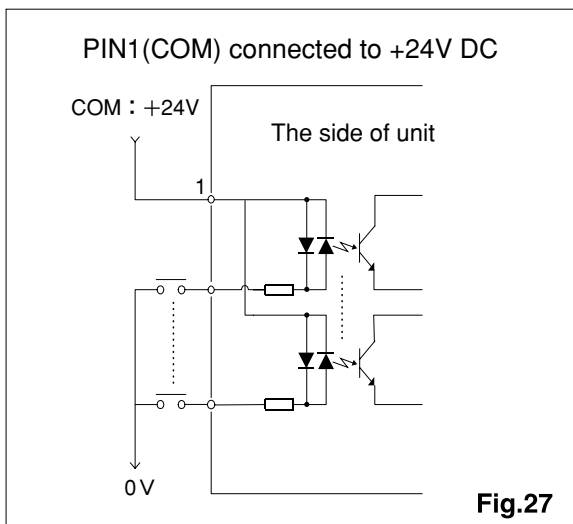

●Output Signal

There are 6 kinds of output signals: “rotating”, “rotating direction”, “rotating pulse”, “rotating speed achieved”, “warning”, and “error”. These signals are pulsed transistor activation signals.

Voltage and Current Specifications

Applied Voltage (V_{max}) $\leq 30VDC$

Working Current (I_p) $\leq 100mA$ (Rotational Pulse 50mA)

Use an external power source for output circuits. It is recommended to use the same 24VDC power source used for input signals. Please refer to **Fig. 29** for connections.

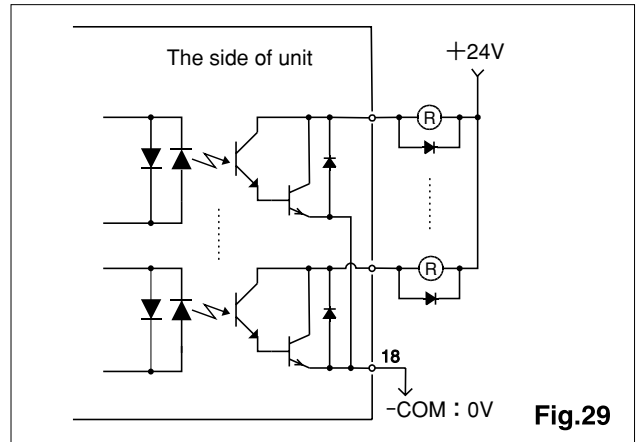

Fig.29

●Motor Speed Control Signal(Motor #1 & #2)

Refer to **Fig.30** for connections.

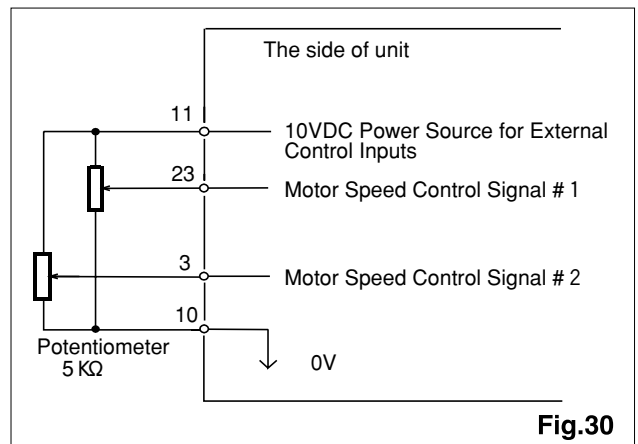

Fig.30

●Monitoring Signals

There are 3 kinds of analog monitoring signals: Motor Current, Torque Load Monitor and Rotating Speed Monitor. Please refer to **Fig. 31** for connections.

Please refer to **Fig. 31** for connections.

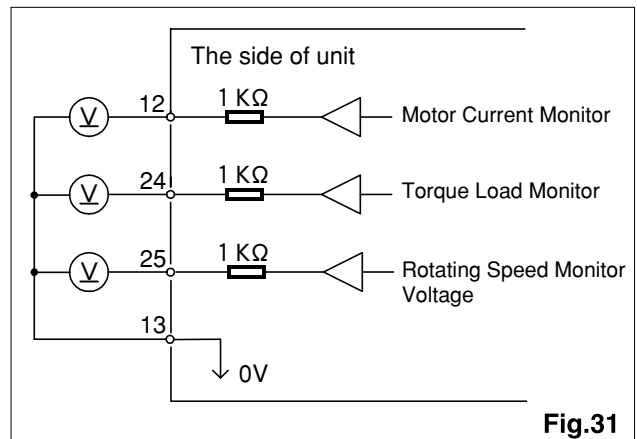

Fig.31

(2) Input/Output Connector B

If you use NE145 -OP1 connected to a machine tool, connect the signal line of SAFE-1A, SAFE-1B, SAFE-1C, SAFE-2A, SAFE-2B to the safety circuit at the side of the machinery in order to build a safety shutdown system with higher reliability.

① Outside INPUT-OUTPUT Connector B Signal Details

CAUTION

• NE-145 does not use PIN No. 1, 3, 4, 9, 11, 12

Pin No.	Pin Name	Description	Input / Output	Signal	Function
1	EMG-IN+	Emergency Stop Signal(+)	Input	External Power Source input for Emergency Stop Signal or Emergency Stop Signal OFF(Open)	External Power Source input for Emergency Stop Signal or Emergency Stop Signal. Normal Operation ON(Closed), Emergency OFF(Open)
2	MT-CNA	Motor Signal Connect Contact A	Output	Continuity, OFF(Open), between PIN2 and PIN10 the motor is connected.	When there is continuity, OFF, between PIN2 and PIN10 the selected motor is connected, if no continuity the motor is disconnected or the motor cord is broken.
3	SAFE-1A	Safety Relay Contact 1A	Output	PIN3 and PIN11 continuity ON(Closed) Safety Relay is OFF	When there is continuity between PIN3 and PIN11 ON(Closed) Safety Relay is OFF(System Stopped), no continuity Safety Relay is OFF(Open) Normal Operation.
4	SAFE-2A	Safety Relay Contact 2A	Output	PIN4 and PIN12 continuity ON(Closed) Safety Relay is OFF	When there is continuity between PIN4 and PIN12 ON(Closed) Safety Relay is OFF(System Stopped), no continuity Safety Relay is OFF(Open) Normal Operation.
5	AUTO+	AUTO Mode Signal(+)	Output	Auto Mode Operation ON(Closed)	When AUTO Mode is being used this Pin is ON(Closed)
6	PWON+	Unit Power Source Monitor(+)	Output	ON(Closed):Main Power Supply is connected OFF(Open):Main Power Supply is disconnected	If the main power supply to the unit is connected this output is ON(Closed)
7	—	Not Used			Not Used
8	—	Not Used			Not Used
9	EMG -IN-	Emergency Stop Signal(-)	Input	External Power Source input for Emergency Stop Signal or Emergency Stop Signal OFF(Open)	External Power Source input for Emergency Stop Signal or Emergency Stop Signal. Normal Operation ON(Closed), Emergency OFF(Open)
10	MT-CNB	Motor Signal Connect Contact B	Output	Continuity, OFF(Open), between PIN2 and PIN10 the motor is connected.	When there is continuity, OFF, between PIN2 and PIN10 the selected motor is connected, if no continuity the motor is disconnected or the motor cord is broken.
11	SAFE-1B	Safety Relay Contact 1B	Output	PIN3 and PIN11 continuity ON(Closed) Safety Relay is OFF	When there is continuity between PIN3 and PIN11 ON(Closed) Safety Relay is OFF(System Stopped), no continuity Safety Relay is OFF(Open) Normal Operation.
12	SAFE-2B	Safety Relay Contact 2B	Output	PIN4 and PIN12 continuity ON(Closed) Safety Relay is OFF	When there is continuity between PIN4 and PIN12 ON(Closed) Safety Relay is OFF(System Stopped), no continuity Safety Relay is OFF(Open) Normal Operation.
13	AUTO-	AUTO Mode Signal(-)	Output	Auto Mode Operation ON(Closed)	When AUTO Mode is being used this Pin is ON(Closed)
14	PWON-	Unit Power Source Monitor(-)	Output	ON(Closed):Main Power Supply is connected OFF(Open):Main Power Supply is disconnected	If the main power supply to the unit is connected this output is ON(Closed)
15	—	Not Used			Not Used

※1  **Caution**
• When using 0V DO NOT connect to PIN10 or 13(Internal Ground) of Input/Output Connector A.

②Input/Output Signals

●Output Signal (PIN No. 2, 10, 5, 13, 6, 14)

There are 3 kinds of output signals: “Motor Signal Connect Detector”, “AUTO MODE” and “Unit Power Source Monitoring”.

These signals are pulsed transistor activation signals.

Voltage and Current Specifications

Applied Voltage (V_{max}) $\leq 30VDC$

Working Current (I_p) $\leq 100mA$ (Rotational Pulse 50mA)

Use an external power source for output circuits. It is recommended to use a separate power from the one used for Input/Output Connector A. Please refer to **Fig. 32** for connections.

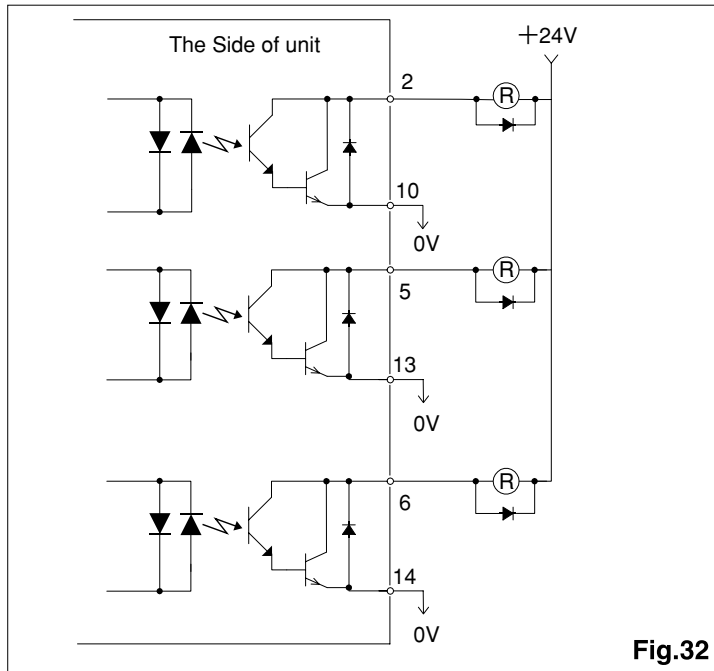

Fig.32

●Emergency Stop Signal Input (PIN No. 1, 9)

This signal is a switched 24VDC output.

Please use a separate power source that is capable of supplying 24VDC $\pm 10\%$, 25mA (5mA/circuit). Refer to Figures below for connections.

Normal Operation circuit is ON(Closed) Emergency Stop circuit is OFF(Open). If the Emergency Stop Signal is OFF(Open) the Safety Relay is OFF and the power supply to the motor is interrupted and the motor stops.

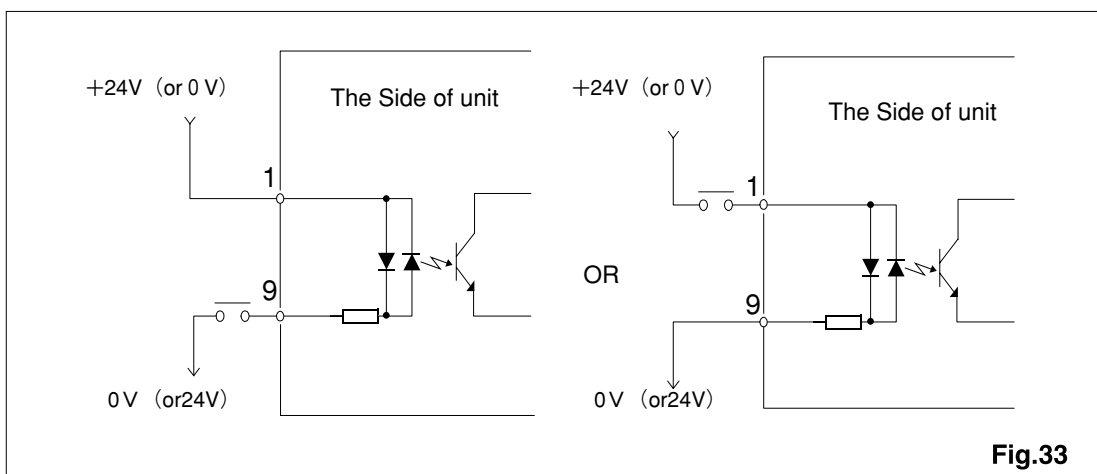

Fig.33

● Safety Relay Signal (PIN No. 3, 4, 11, 12)

- The Safety Relay will be ON or OFF depending on the state of the Emergency Stop Signal PIN1,9.
- When there is continuity between PIN3(SAFE-1A) and PIN11(SAFE-1B) or between PIN4(SAFE-2A) and PIN12(SAFE-2B) the motor is off. If there is no continuity between these pairs of pins then the system is operating normally.
- If the Emergency Stop Signal is OFF(Open) the Safety Relay will be OFF(Open) and the motor power will be interrupted and the motor will stop.
- If the 'a' contacts of the Safety Relay are welded together by an over load or short circuit the 'b' contacts' separation are maintained with more than 0.5mm spacing by the relay's recoil mechanism.
- The voltage/current specifications of PIN3, 11 & PIN4, 12 are Input Voltage $\leq 30V$ DC, Continuous Current $\leq 2A$.

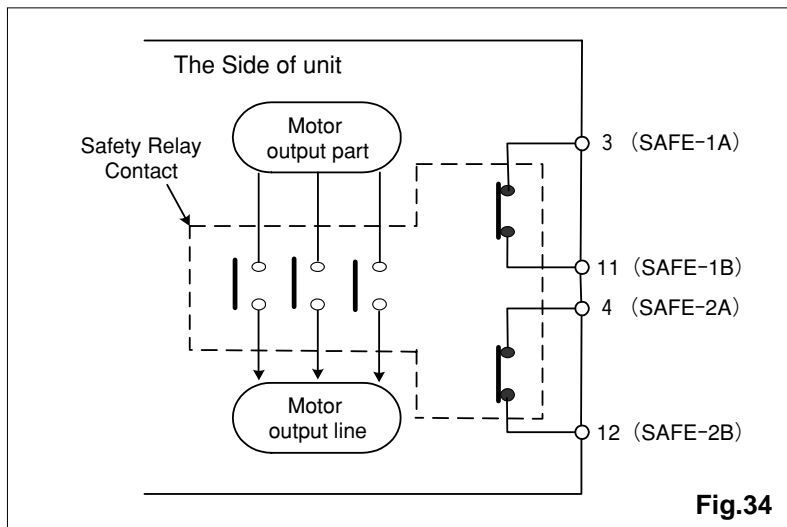

Fig.34

(3) Input/Output Signal Connector Specifications

Input/Output Connector A

Plug Part Number : XM2A-2501 OMRON(or other similar high-quality product)

Cover Part Number : XM2S-2511 OMRON(or other similar high-quality product)

Input/Output Connector B

Plug Part Number : XM2A-1501 OMRON(or other similar high-quality product)

Cover Part Number : XM2S-1511 OMRON(or other similar high-quality product)

- The Plug and Cover are not provided with the system. Please purchase the specified plug and cover from local suppliers.
- Use only shielded cables to minimize RF interference and noise. Connect the shield to the plug cover.
- Different makers use different names for the cover.

⚠ CAUTION

To minimize RF interference and noise please keep the length of the cables as short as practical and route separate from power cables.

(4) Input/Output Connector A,B Pin Configuration

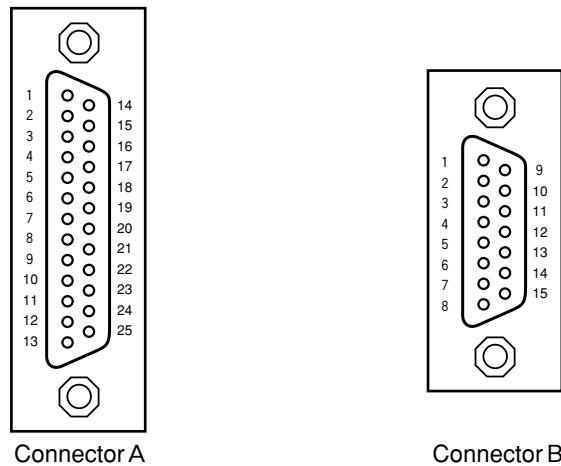

Fig.35

19 Protect Function

(1) WARNING Function

Always check the control unit, motor, spindle and the condition of the cooling air prior to use. This will help prevent system errors that will result in undesired operating conditions.

- The WARNING LED ⑳ will flash.
- The WARNING Code (listed in Table 1) will be displayed on the Digital Speed Indicator ㉑.
- A WARNING Signal is output to the WARNING Signal (PIN No. 20:WARNING) of Input/Output Connector A.

Table 1

WARNING Code	Warning Function	Trouble
A 0	Motor Cord	Motor Cord or Connector is disconnected or misaligned
A 1	Low Air Pressure	Low Air Pressure
A 3	Over Load	Motor Torque load exceeding safe limits
A 4	Emergency Stop	Emergency Stop system activated

Note: When using the Input/Output Connector and external monitoring, please check and resolve the source of the trouble anytime a Warning Code is displayed.

(2) Detection of unsafe operating conditions

Always check the control unit, motor, spindle and the condition of the cooling air prior to use. This will help prevent system errors that will result in undesired operating conditions.

- Motor stops
- The Error LED㉒ will flash.
- Error Code (listed in Table 2) will be displayed on the Digital Speed Indicator ㉑.
- An Error signal is output to the Error Signal (PIN No. 8:ERR) of Input/Output Connector A.

(3) Resetting System after Error Codes

There are 2 methods of releasing error codes.

- Push Error Reset Switch ⑳ RESET on the front panel.
- Switch the signal on PIN4(RESET) of Input/Output Connector A OFF(Open)-ON(Closed)-OFF(Open).

Table 2

Error Code	Problem Area	Trouble
E 1	Excess Current	Motor Current beyond safe limits.
E 2	Over voltage	Motor Voltage beyond safe limits.
E 3	Motor Sensor	Trouble with the sensor signal in the motor.
E 4	Control Unit Overheat	Internal Temperature of the Control Unit too High.
E 5	Brake Circuit Trouble	Trouble with the motor brake circuit.
E 6	Rotor Lock	Motor stalled for more than 3 seconds.
E 7	Low Air Pressure	Inadequate air supplied for more than 4 seconds during rotation or inadequate air supply when motor start commanded.
E 8	Torque Overload	Torque limits exceeded for too long a period of time. See (4) on Page 24.
E 9	Trouble with Power Source	Trouble with the power source inside the control unit.
E A	External Control Signal Error	External control sequencing problem.
E C	Internal Memory Error	Trouble with memory (EEPROM) .
E E	Emergency Stop Error	Safety Relay has been activated and the Emergency Stop System has stopped the motor.
E H	Over Speed	Rotating speed is beyond the set speed for too long.

Note: • When using the Input/Output Connector and external monitoring, please check and resolve the source of the trouble anytime a WARNING Code is displayed.

- The following Error Codes cannot be released: E4(Control Unit Overheat), E5(Brake Circuit Trouble), E9(Trouble with Power Source), EC(Internal Memory Error). Once the source of the error is corrected, turn the system off and the Error Code will be released when the system is turned on.

(4) Torque Overload

When the Load Monitor LED (Load) ㉕ lights 4 or more LEDs (3 green LEDs and 1 or more yellow LEDs) an overload condition exists. During overload operation the following occurs.

- WARNING LED (Warning) ㉖ flashes
- WARNING Code A3 is displayed on the Digital Speed Indicator ㉗
- WARNING Signal is output to the WARNING Signal PIN20 (Warning) of Input/Output Connector A

Overload operation is considered short term operation mode. The allowable operation time depends on the number of lighted LEDs on the Load Monitor LED (Load) ㉕. The allowable time is detailed below.

- Load Monitor LED 4 LEDs: 40 Seconds
- Load Monitor LED 5 LEDs: 20 Seconds
- Load Monitor LED 6 LEDs: 10 Seconds

When the allowable time is exceeded the motor will stop and the following occurs.

- Error LED (Error) ㉘ flashes
- Error Code E8 is displayed in the Digital Speed Indicator ㉗.
- Error Signal is output to the error signal PIN8(ERR) of Input/Output Connector A.



CAUTION

If you operate the system in short term operation for long periods of time the control unit will overheat and damage to the motor and spindle is possible. NSK recommends only continuous duty operation(Load LED has 3 LEDs lit; Torque Load Monitor(Load) voltage is less than 5V.

20 Break-In Procedure

The E2550 is a high-precision, high-speed motor-spindle, the following procedure must be followed to ensure proper operation and longevity.

During transportation, storage or installation the grease inside the bearings will settle. If the motorspindle is suddenly run at high-speed excessive heat will cause bearing damage. After installation, repair, initial operation, or long periods of non operation please follow the break-in procedure detailed in Table 3.

Table 3

Steps	1	2	3	4
RPM (min ⁻¹)	15,000	30,000	40,000	50,000
Running Time	15 min	10 min	10 min	15 min
Items to Check	No Abnormal Noises	Spindle Housing no hotter than 20°C. If hotter than 20°C check installation and restart Break-In procedure.	Spindle Housing no hotter than 20°C. If hotter than 20°C stop for at least 20 minutes, check installation and restart Break-In procedure.	Spindle Housing less than 20°C.

21 Cutting tool cautions

①The proper surface speed for vitrified grindstones is 600-1800m/min.

⚠ CAUTION

Do not exceed a surface speed of 2,000m/min for grinding.

$$\text{Surface Speed (m/min)} = \frac{3.14 \times \text{Diameter (mm)} \times \text{rotation Speed (min}^{-1}\text{)}}{1,000}$$

②Do not exceed 13mm overhang for mounted grindstones. In case overhang must exceed 13mm reduce the motor speed in accordance with **Fig.36**.

③Do not use tools with bent or broken shanks, cracks or excessive runout.

④Dress the grindstone prior to use.

⑤For grinding the maximum depth of cut should not exceed 0.01mm radially or axially. Reciprocate the tool several times after each in feed step.

⑥Always operate tools within the tool manufacturer's recommended speed limits. Use of a tool outside of the manufacturer's recommended speed limits could cause damage to the spindle and injury to the operator.

⑦Keep the tool shank and collet clean. If contaminants are left in the collet they can cause excessive runout and damage the tool and spindle.

⑧Do not drop or hit spindle.

Table 4 Overhang and Speed

Overhang (mm)	Speed (min ⁻¹)
20	Nx0.5
25	Nx0.3
50	Nx0.1

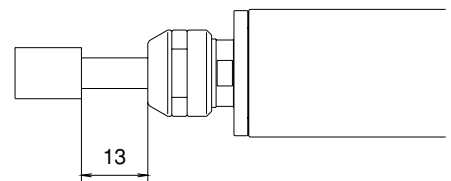

Fig.36

※ N=Max. operating speed at 13mm overhang.

22 Trouble Shooting

Trouble	Cause	Inspect/Corrective Action
Motor Does Not Run	Power is not supplied	Check the Main Power Inlet connection on the front of the unit
	Motor Cord or Connector Disconnected	Connect the Motor Cord to the connector or check the Motor Cable
	Controller Switch is set to "MANUAL" but trying to start with an external command signal through Input/Output Connector A	Start with the Start Switch on the Control Panel, or set the Controller Switch to Auto
	Controller Switch is set to "AUTO" but trying to start with the Start Switch on the Control Panel	Start with an external command signal or set the Controller Switch to Manual
	Motor Cord is connected to the wrong Motor Connector. Emergency Stop Signal on Input/Output Connector B is OFF(Open) NE145-OP1 Only	Check the Motor Cord connection and correct if necessary. Check the source of the Emergency Stop Signal and correct the problem. After correcting the problem, restart the system.
	Error Code Indicated	Check and correct the source of the Error Code
	Low Air Pressure	Adjust air pressure to between 0.15MPa-0.25MPa
Motor does not reach the preset speed	Auto Mode Motor Speed Control setting, in the 'P2' parameters, is set to external command signal and trying to adjust speed with potentiometer or Auto Mode Motor Speed Control setting, in the 'P2' parameters is set to potentiometer and trying to adjust speed with external command signal.	Reset the Auto Mode Motor Speed Control parameters.
	500 min ⁻¹ Centering Rotation Mode is selected.	Check the front panel settings and input on Input/Output Connector A PIN No.16(500min ⁻¹) and correct as necessary.
	Motor Fixed Speed is set in the 'P3 or P4' parameters.	Check the 'P3 and P4' parameter settings and adjust as needed.
	Maximum Motor Speed is set in the 'P5 or P6' parameters.	Check the 'P5 and P6' parameter settings and adjust as needed.
High Run-Out	Foreign Particles stuck in the collet chuck or spindle	Clean the inside of the collet chuck and spindle
	Collet Nut is not properly positioned	Position the collet nut properly
	Ball Bearings Worn	Send to NAKANISHI for Repair
Abnormal Vibration or Noise during Operation	Foreign Particles in the ball bearings. Ball Bearings Worn	Send to NAKANISHI for Repair
	Tool out of Balance	Change the tool

23 E2550 System Chart

- A wide variety of attachments are available depending on the application requirements
- Speed reducers are available to reduce spindle speed and increase torque.
- The (+) drive spindles were designed to be used with (+) drive motors and speed reducers.

⚠ CAUTION

DO NOT run spindles or speed reducers above the recommended speed. Failure to follow this caution will dramatically reduce life expectancy and damage internal components.

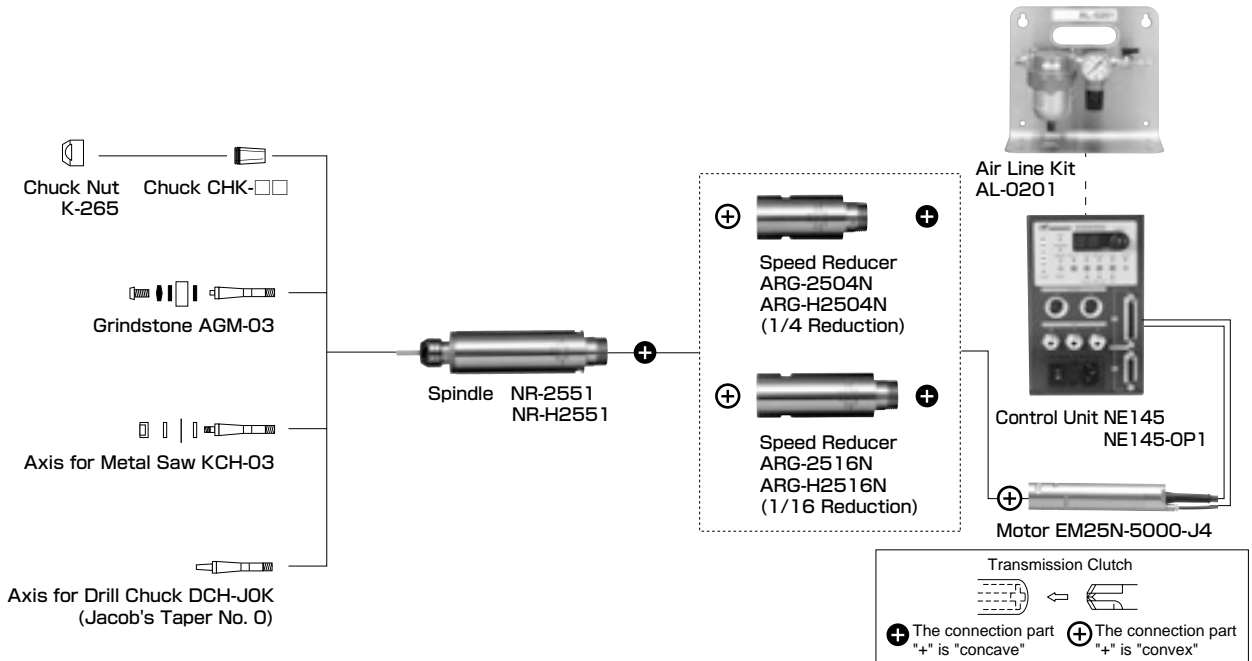

24 Setting of Operating Parameters

The following operating parameters can be preset depending on the application requirements. The operating parameter presets are retained in non-volatile memory and will be maintained even if power is disconnected.

① Setting the Error Output Mode

- When an operating error occurs, an error signal will be output to Input/Output Connector A. This output can be set to normally ON(Closed) or normally OFF(Open).

② Setting AUTO Mode Motor Speed Control

Control Mode is set to AUTO

- Motor Speed can be controlled by the potentiometer on the Control Panel.
- Motor Speed can be controlled by external command signal to Input/Output Connector A. PIN No.23:VR1 controls motor #1; PIN No.3:VR2 controls motor #2.

③ Setting Fixed Motor Speed for Motor #1 and #2

- Single Motor Speed is desired.
- Machine Operator can not change motor speed.

④ Setting the Maximum Motor Speed for Motor #1 and #2

- Set maximum motor speed to the maximum allowable speed for the cutting tools being used.
- Set the maximum motor speed to the maximum recommended speed for the spindle being used.

⑤ Selection of the type of external signal for motor start method

Allows selection of Start signal and Direction Signal or REV. Start and FWD.Start signals.

⑥ Air Input monitoring override

The system can be configured to operate without cooling air, maximum speed is 30,000min⁻¹.

⚠ CAUTION

Once a parameters default setting has been changed the setting will be maintained even if power is disconnected. Please set the Error Output Mode, AUTO Mode Motor Speed Control, Fixed Motor Speed for Motor #1 and #2, and Maximum Motor Speed for Motor #1 and #2.

▲ Entering Parameter Setting Mode

- While pushing and holding the Reset Switch turn the Power Switch On. Hold the Reset Switch down for 3 seconds, the buzzer will 'beep' 3 times, release the Reset button and Parameter Setting Mode will start. The Start LED flashes to indicate Parameter Setting Mode is active.
- Motor Start/Stop commands and the Start Switch on the Control Panel are disabled during Parameter Setting Mode.
- Cycling the Power Switch will exit Parameter Setting Mode and return the system to normal operating mode.
- After entering Parameter Setting Mode the parameters to be set can be selected by turning the potentiometer.

 ~  and 



Error Output Mode



AUTO Mode Motor Speed Control



Fixed Motor Speed for Motor #1



Fixed Motor Speed for Motor #2



Maximum Motor Speed for Motor #1



Maximum Motor Speed for Motor #2



External Motor Start Signal Control Mode



Air Input monitoring override



 ~ 

Confirm settings of parameters P1-P8

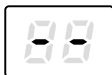

Not Used

▲Setting Error Output Mode



- Allows setting of the output signal on PIN No.8:ERR of Input/Output Connector A.
- When an error occurs the output can be set to ON(Closed) or OFF(Open).

Procedure) 1. Push the Start Switch

2. is displayed. This indicates that when an error occurs the output will be OFF(Open).

3. Push the Start Switch

4. is displayed. This indicates that when an error occurs the output will be ON(Closed).

5. You can cycle through the choices by pushing the Start Switch.

6. Push the Reset Switch to send the settings to memory will be displayed depending on the position of the potentiometer.

7. If you desire to set other parameters turn the potentiometer to select the parameter to be set.

8. If you are finished setting parameters, turn the Power Switch off.

If the Error Output Mode has been changed from the default setting,

that setting will be displayed the next you enter Parameter Setting Mode.

▲Setting AUTO Mode Motor Speed Control

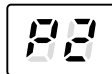



- Allows the setting of the manner in which motor speed can be controlled when the system is being used in AUTO mode (External Command Signal Control).
- This parameter selects between speed control with the Motor Speed Adjustment Switch or by External Command Signal through Input/Output Connector A .

Procedure) 1. Push the Start Switch

2. is displayed. This indicates that speed control is by External Command Signal Control and the Motor Speed Adjustment Switch are Disabled.





3. Push the Start Switch.

4.  is displayed. This indicates that speed control is by the Motor Speed Adjustment Switch and the External Command Signal Control for speed is Disabled.
5. You can cycle through the choices by pushing the Start Switch.
6. Push the Reset Switch to send the settings to memory  will be displayed depending on the parameter being set.
7. If you desire to set other parameters push the Motor Speed Adjustment Switch to select the parameter to be set.
8. If you are finished setting parameters, turn the Power Switch off.

▲Setting Fixed Motor Speed for Motor #1

- Allows the motor speed of Motor #1 to be fixed.
- Fixes the motor speed in both MANUAL and AUTO modes.

Procedure) 1. Push the Start Switch

2.  is displayed. This indicates that Fixed Motor Speed cannot be set.
3. Push the Start Switch.
4.  is displayed. This indicates that Fixed Motor Speed can be set.
5. The Digital Speed Indicator will oscillate between on the selected motor speed and motor speed can be selected by turning the potentiometer. The speed control range is 5,000-50,000min⁻¹.
6. Push the Reset Switch to send the settings to memory  ~  or  will be displayed depending on the position of the potentiometer.
7. If you desire to set other parameters turn the potentiometer to select the parameter to be set.
8. If you are finished setting parameters, turn the Power Switch off.

▲Setting Fixed Motor Speed for Motor #2

- Allows the motor speed of Motor #2 to be fixed.
- Fixes the motor speed in both MANUAL and AUTO modes.

Procedure) 1. Push the Start Switch

2.  is displayed. This indicates that Fixed Motor Speed cannot be set.

3. Push the Start Switch.

4.  is displayed. This indicates that Fixed Motor Speed can be set.

5. The Digital Speed Indicator will oscillate between  on the selected motor speed and motor speed can be selected by turning the potentiometer. The speed control range is 5,000-50,000 min⁻¹.

6. Push the Reset Switch to send the settings to memory, Parameter number will be displayed depending on the position of the potentiometer.

7. If you desire to set other parameters turn the potentiometer to select the parameter to be set.

8. If you are finished setting parameters, turn the Power Switch off.

▲Setting Maximum Motor Speed for Motor #1



- Allows the setting of the maximum motor speed for Motor #1
- The set maximum motor speed effects both MANUAL and AUTO control Modes.

Procedure) 1. Push the Start Switch

2.  is displayed. This indicates that the Maximum Motor Speed is not set.

3. Push the Start Switch.

4.  is displayed. This indicates that the Maximum Motor Speed is ready to be set. Maximum motor speed is displayed on the Digital Speed Indicator.

5. The Digital Speed Indicator will oscillate between on the selected motor speed and motor speed can be selected by turning the potentiometer. The speed control range is 5,000-50,000 min⁻¹.

6. Push the Reset Switch to send the settings to memory Parameter number will be displayed depending on the position of the potentiometer.

7. If you desire to set other parameters turn the potentiometer to select the parameter to be set.

8. If you are finished setting parameters, turn the Power Switch off.

▲Setting Maximum Motor Speed for Motor #2

- Allows the setting of the maximum motor speed for Motor #2
- The set maximum motor speed effects both MANUAL and AUTO control Modes.

Procedure) 1. Push the Start Switch

2.  is displayed. This indicates that the Maximum Motor Speed is not set.

3. Push the Start Switch.

4.  is displayed. This indicates that the Maximum Motor Speed is ready to be set.

Maximum motor speed is displayed on the Digital Speed Indicator. 





5. The Digital Speed Indicator will oscillate between on the selected motor speed and motor speed can be selected by turning the potentiometer. The speed control range is 5,000-50,000 min⁻¹.

6. Push the Reset Switch to send the settings to memory Parameter number will be displayed depending on the position of the potentiometer.

7. If you desire to set other parameters turn the potentiometer to select the parameter to be set.

8. If you are finished setting parameters, turn the Power Switch off.

▲Setting External Motor Start Signal Control Mode

- During Auto Control Mode the motor Start signal can either by a direction signal and a Start signal or a FWD. Start and a REV. Start signal. When  is set to  the rotation direction is controlled by Pin No.2 DIR_IN, FWD. (Open), REV.(Closed) and the Start signal is controlled by Pin No.14 : START When  is set to  FWD. rotation is controlled by Pin No.14 : START and REV. rotation is controlled by Pin No.2 : DIR_IN.

Procedure) 1. Push the Start Switch

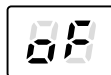
2.  is displayed. This indicates that the control mode is set to direction signal and start signal.

3. Push the Start Switch

4.  is displayed. This indicates that the control mode is set to FWD. ON, REV. ON mode.

5. Push the Error Reset Switch to send the settings to memory  will be displayed depending on the parameter being set.
6. If you desire to set other parameters push the Motor Speed Adjustment Switch to select the parameter to be set.
7. If you are finished setting parameters, turn the Power Switch off.

▲Setting Air Input monitoring override

- The system can be set to operate without cooling air. Maximum speed is 30,000min⁻¹ when not using cooling air.

Note : It is not recommended to use the system in this manner for general machining.

This setting is only for light cutting and not for use with coolants.

Procedure) 1. Push the Start Switch

2.  is displayed. This indicates that air must be supplied to operate the system.

3. Push the Start Switch



4.  is displayed. The system can be configured to operate without cooling air, maximum speed is 30,000min⁻¹.

5. Push the Error Reset Switch to send the settings to memory  will be displayed depending on the parameter being set.



6. If you desire to set other parameters push the Motor Speed Adjustment Switch to select the parameter to be set.

7. If you are finished setting parameters, turn the Power Switch off.

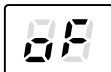

▲Confirmation of the Parameter Settings

- Allows user to check the settings of the above parameters  ~ 



Procedure) 1. Push the Start Switch

2. Display oscillates between  and  or  (by turns)(the setting for P1)

3. Push the Start Switch



4. Display oscillates between  and  or  (by turns)(the setting for P2)

5. Push the Start Switch



6. Display oscillates between  and  (the setting for P3 for example,

 is displayed at 30,000min⁻¹)



7. Push the Start Switch

8. Display oscillates between  and  (the setting for P4 or the setting speed by turns)



9. Push the Start Switch

10. Display oscillates between  and  (the setting for P5 or maximum speed by turns)



11. Push the Start Switch

12. Display oscillates between  and  (the setting for P6 or the setting speed by turns)

13. Push the Start Switch.

14. Display oscillates between  and  or  (by turns) (the setting for P7)

15. Push the Start Switch



16. Display oscillates between  and  or  (by turns) (the setting for P8)

17. Push the Start Switch Repeat from procedure2

18. Return to confirmation of P1, or push Reset switch to finish

▲ Default Parameter Settings

When the system is shipped from NAKANISHI's factory all parameters

 ~  are set to 

▲ Control Panel Setting Resume Function

On power up the system will resume all the Control Panel settings in the position they were in when the system was shut off.

The following settings will be maintained:

1. Motor Selection (Motor1, Motor2)
2. Rotating Direction (FWD, REV)
3. Control Mode (AUTO, MANUAL)
4. 500min⁻¹ speed selection
5. Parameter Settings

※Contents are subject to change without notice.

NAKANISHI INC. 
www.nakanishi-inc.com

700 Shimohinata Kanuma-shi Tochigi 322-8666, Japan

NSK America Corp
www.nskamericacorp.com

1800 Global Parkway Hoffman Estates, IL 60192, USA