

ASTRO-E 400Z/500Z/800Z SYSTEM

OPERATION MANUAL

OM-K0356E Rev.1



contents

INSTRUCTIONS AND WARNING-Electric Devices···	1	12. Connecting the Motor and Spindle···	11
1. Cautions for handling and operation···	2	13. Changing Tools ·······················	11
2. Features······························	4	14. Replacing the Collet··················	12
3. Specifications························	4	15. Fixturing the Motor and Spindle······	12
4. Torque/Output Characteristics··········	5	16. Operation Procedures················	13
5. Nomenclature························	6	17. External Input/Output Control Signal Specifications···	15
6. Diagrams····························	8	18. Protect Function······················	20
7. Input Voltage Switching (115V-230V)···	8	19. Break-In Procedure··················	21
8. Changing Fuses ·······················	9	20. Cutting tool cautions················	22
9. Power Cord Connection················	9	21. Optional Parts······················	23
10. Motor Cord Connection ···············	10	22. Trouble Shooting····················	25
11. Air Hose Connection··················	10		

IMPORTANT INSTRUCTIONS AND WARNING - Electric Devices

WARNING!

When using electric tools, basic safety precautions should always be followed to reduce the risk of fire, electrical shock and personal injury, including the following.

Read all these instructions before operating this product and save these instructions.

GROUNDING INSTRUCTIONS

1. In the event of a malfunction or breakdown, grounding provides a path of least resistance for electric current to reduce the risk of electric shock. This tool is equipped with an electric cord with a grounding conductor and a grounding plug. The plug must be plugged into a matching outlet that is properly installed and grounded in accordance with all local codes and ordinances.
2. Don't modify the plug provided - if it will not fit the outlet, have the proper outlet installed by a qualified electrician.
3. Improper connection of the grounding conductor can result in electric shock. The conductor with insulation having an outer surface that is green with or without yellow stripes is the grounding conductor. If repair or replacement of the electric cord or plug is necessary, do not connect the grounding conductor to a live terminal.
4. Check with a qualified electrician or service person if the grounding instructions are not completely understood, or if in doubt as to whether the tool is properly grounded.
5. Use only 3-wire extension cords that have 3-prong grounding plugs and 3-pole receptacles that accept the tool's plug.
6. Repair or replace damaged or worn cord immediately.
7. This tool is intended for use on a circuit that has an outlet that looks like the one illustrated in Sketch A in Figure (below) (115V). The tool has a grounding plug that looks like the plug illustrated in Sketch A in Figure (below). A temporary adapter, which looks like the adapter illustrated in Sketches B and C, may be used to connect this plug to a 2-pole receptacles as shown in Sketch B if a properly grounded outlet is not available. The temporary adapter should be used only until a properly grounded outlet can be installed by a qualified electrician. The green-colored rigid ear, lug, and the like, extending from the adapter must be connected to a permanent ground such as a properly grounded outlet box.

Grounding Method

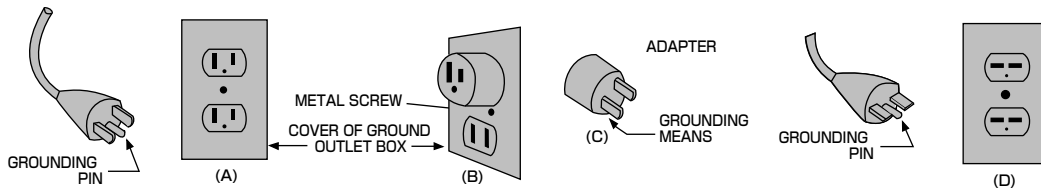

8. USE PROPER EXTENSION CORD. Make sure your extension cord is in good condition. When using an extension cord, be sure to use one heavy enough to carry the current your product will draw. An undersized cord will cause a drop the line voltage resulting in loss of power and overheating. Table (below) shows the current size to use depending on cord length and nameplate ampere rating. If in doubt, use the next heavier gage. The smaller the gage number, the heavier the cord.

Minimum gage for cord

Ampere Rating		Volts	Total length of cord			
		120V 240V	7.5m(25ft.) 15m(50ft.)	15m(50ft.) 30m(100ft.)	30m(100ft.) 60m(200ft.)	45m(150ft.) 90m(300ft.)
More Than	Not More Than					
0	6		18	16	16	14
6	10		18	16	14	12
10	12		16	16	14	12
12	16		14	12	Not Recommended	



Only the applicable parts of the Table need to be included. For instance, a 120-volt product need include the 240-volt heading.

Thank you for purchasing the Ultra-Precision, High-Speed spindle system, ASTRO-E 400Z/500Z/800Z. ASTRO-E400Z/500Z/800Z System is designed for use on CNC lathes, robots, NC lathes and special purpose machines. The motor, spindle and control unit are designed to work as an integrated system capable of 0-40,000min⁻¹(400Z) ,0-50,000 min⁻¹(500Z),0-80,000min⁻¹ (800Z). This system utilizes air to cool the motor and protect the spindle from contaminants, please use an airline kit to ensure that clean, dry, properly regulated air is supplied to the motor and spindle. Please read this Operation Manual carefully prior to use.

1 Cautions for handling and operation

■ Read these cautions carefully and only use in the manner intended.

■ Safety instructions are intended to avoid potential hazards that could result in personal injury or damage to the system. Safety instructions are classified as follows in accordance with the seriousness of the risk.

Class	Degree of Risk
 WARNING	A hazard that could result in bodily injury or damage to the system if the safety instructions are not followed
 CAUTION	A hazard that could result in light to moderate bodily injury or damage to the system if the safety instructions are not followed.

WARNING

- ① **The ASTRO-E400Z/500Z/800Z is not a hand tool. It is designed to be installed on a NC lathe or a special purpose machine.**
- ② **DO NOT connect or disconnect the electric cord or operate ASTRO-E400Z/500Z/800Z with wet hands. Failure to follow this warning may result in electric shock.**
- ③ **Protect ASTRO-E400Z/500Z/800Z control unit from coolants and moisture contamination. Failure to protect the control unit can result in damage to internal components and short-circuits within the ASTRO-E400Z/500Z/800Z control unit and possible injury to the operator or other personnel.**
- ④ **Always use a protective cover around the spindle, wear safety glasses, dust mask, hearing protection and gloves while the motor is running.**
- ⑤ **Never touch the motor, spindle or cutting tools while the system is operating.**
- ⑥ **Use only the proper input power source voltage and check the voltage setting on the ASTRO-E400Z/500Z/800Z control unit to prevent damage to the control unit or injury to the operator.**

 **CAUTION**

- ① **DO NOT** block the cooling vent on the back of ASTRO-E400Z/500Z/800Z control unit. Blocking the air vents will greatly increase heat buildup in the control unit and cause damage to the internal components of the control unit.
- ② When using tools at motor speeds of less than $2,000\text{min}^{-1}(\text{rpm})$, the appropriate speed reducer(For ASTRO-E400Z/500Z)needs to be attached.
- ③ Please check to ensure that the average spindle load does not exceed the continuous use area of the load meter. Check the (Load Monitor) and make sure that no more than the 3 green LED's are lit.
- ④ Only use tools at less than the maximum speed recommended by the tool manufacturer. (Use of tools in excess of the manufacturer's maximum allowable speed can cause damage to the motor, spindle and machine tool and possible operator injury.)
- ⑤ Always clean the tool shank and the chuck prior to use. If ground particles or metal chips are stuck inside the spindle or chuck, this will cause damage to the chuck and/or spindle and loss of precision.
- ⑥ Do not install the ASTRO-E400Z/500Z/800Z near RF noise sources this can cause malfunction or damage.
- ⑦ When error lamp flashes or errors occur, the motor will stop. Before restarting the system or continuing operation, check and correct the cause of the malfunction. Failure to correct the problem will result in damage to the control unit, motor and spindle.
- ⑧ Always check the cause of a warning when Warning Lamp flashes or Warning output signal is detected.
- ⑨ **DO NOT** drop or hit the control unit, the motor and/or spindle. This will cause damage to the internal components and result in reduced performance, precision and possible system failure.
- ⑩ Clean dry air is required for cooling the motor and preventing contaminants from entering the motor and/or spindle. If dust or water enters the motor and/or spindle, it will result in damage to the motor and spindle.
- ⑪ Make sure that the collet chuck is firmly tightened prior to rotating the spindle.
- ⑫ The motor can be rotated at 500min^{-1} for centering. Do not attempt to use 500min^{-1} for machining.
- ⑬ Do not disassemble or attempt to repair the motor, spindle or control unit. There are no user servicable parts in the system.
- ⑭ Do not place anything on ASTRO-E400Z/500Z/800Z control unit. This will cause damage to the control unit.
- ⑮ If smoke, noise or strange odors are emitted from the control unit or motors, immediately turn off the power switch.
- ⑯ The connector cap needs to be installed on CN1/CN2, when AUTO control mode is not used or if CN1/CN2 are not being utilized.

2 Features

- ① A high-speed brushless motor is used to achieve extremely high speed and eliminate the nuisance of brush maintenance.
- ② Motor speed is digitally displayed.
- ③ Wide motor speed range: 0-40,000min⁻¹(400Z) ,0-50,000min⁻¹(500Z) and 0-80,000min⁻¹(800Z).
Cutting speed range is: 2,000-40,000min⁻¹(400Z) 2,000-50,000min⁻¹(500Z) and 20,000-80,000min⁻¹(800Z). The motor can also be set for 500 min⁻¹ rotation for centering.
- ④ Automatic control and monitoring of spindle functions are possible.
- ⑤ The motor/spindle housing is made of Stainless Steel (SUS-416) precision ground to Ø30mm OD.
The motor/spindle is very easy to mount on NC lathes or special purpose machines.
- ⑥ A wide variety of spindles and speed reducers are available making this system highly flexible.
- ⑦ Wide range of collet chucks is available.
- ⑧ The front panel of the ASTRO-E400Z/500Z/ 800Z control unit can be detached and the cord can be extended to Max.4m with 'the control panel extension cord' (option). This cord allows the control unit's front panel to be remotely mounted in a convenient location.
- ⑨ A safety relay is installed to conform to European safety standards.
The 'a' contact is used for the electric line and the 'b' contact output makes detection of an open motor electric line circuit possible. This system can be integrated with the machine's safety systems to help enhance safe, automatic operation.
- ⑩ The Emergency Stop Signal can be used to operate the safety relay automatically. When the Emergency Stop Signal circuit is open the power lines between the control unit and the electric motor are disconnected.
- ⑪ ASTRO-E400Z/500Z/800Z is capable of being connected to 115V to 230V power sources. The control unit incorporates a voltage selection switch; this switch is set to the proper position for the voltage being used.

3 Specifications

① Control Unit

Model	NE147-400(ASTRO-E400Z) NE147 (ASTRO-E500Z)	NE 147-800 (ASTRO-E800Z)
Power Requirements	AC115V/230V 50/60Hz	
Speed Range	1) 2,000~40,000min ⁻¹ (NE147-400) 2,000~50,000min ⁻¹ (NE147) 2) 500min ⁻¹ (for centering only)	1) 20,000~80,000min ⁻¹ 2) 500min ⁻¹ (for centering only)
Power Consumption	180W	
Weight	5.8Kg	
Dimensions	W210×D290×H97mm	

② Motor

Model	ASTRO-E400Z		ASTRO-E500Z		ASTRO-E800Z	
Motor type	EM-401 EM-405	EMS-3041 EMS-3045	EM-501 EM-505	EMS-3052 EMS-3056	EM-801	EM-805
Motor speed	2,000~40,000min ⁻¹		2,000~50,000min ⁻¹		20,000~80,000min ⁻¹	

③ Spindle

Model	ASTRO-E400Z		ASTRO-E500Z		ASTRO-E800Z	
Spindle Type	NR-402E	EMS-3041 EMS-3045	NR-452E	EMS-3052 EMS-3056	NR-3080	NRA-5080
Adoptable Motor	EM-401 EM-405		EM-501 EM-505		EM-801 EM-805	
Allowed motor speed	40,000min ⁻¹		50,000min ⁻¹		80,000min ⁻¹	
Spindle Accuracy	Within 1 μm					

④ HES500

Model	ASTRO-E500Z	
	HES500-BT30/NT30 HES500-BT50/NT50 HES500-HSK A100	HES500-BT40/NT40 HES500-HSK A63
Allowed Motor Speed	6,000~50,000min ⁻¹	

Standard Accessories

- Power Cord
- Connector Cover A (Provided)
- Noise Reduction Coil
- Air Hose with Filter
- Fuse
- Reducer (φ 6 - φ 4)
- Connector Cover B (Provided)
- Operation Manual

4 Torque/Output Characteristics

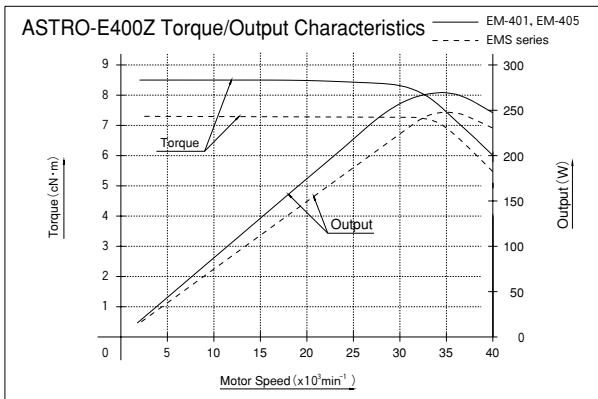

ASTRO-E400Z

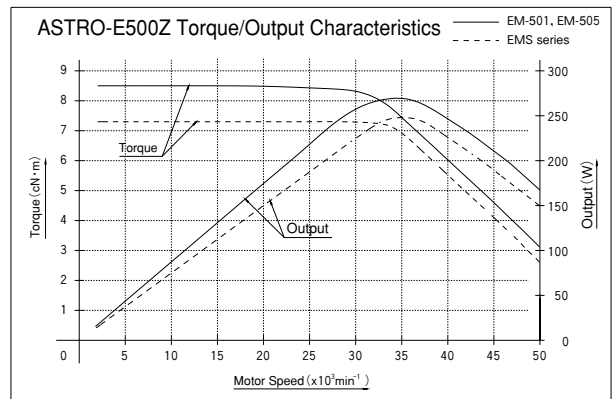

ASTRO-E500Z

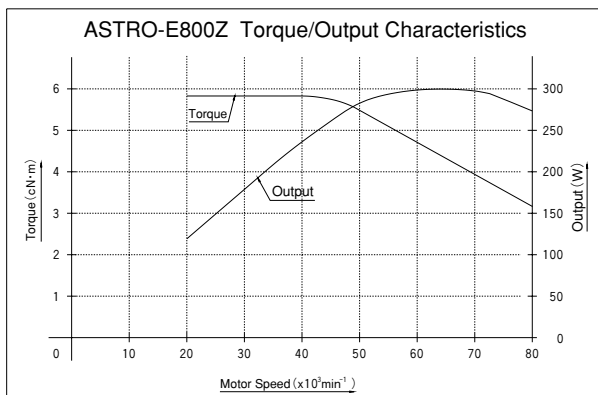

ASTRO-E800Z

5 Nomenclature

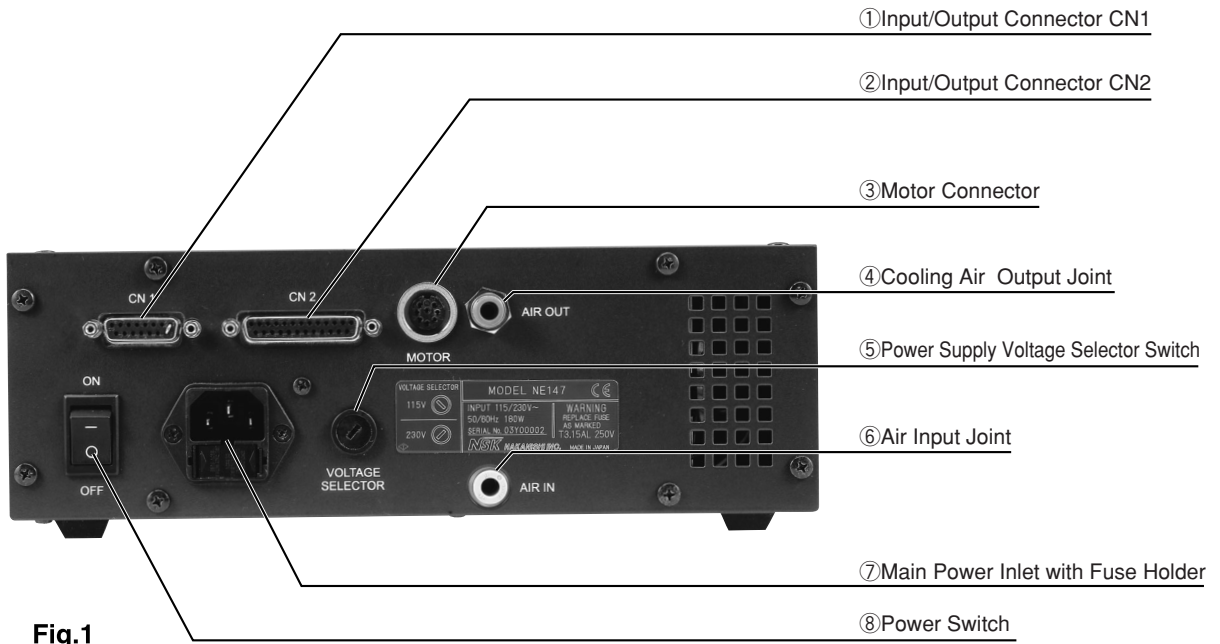

Fig.1

(1) Control unit (Fig.1)

① Input/Output Connector CN1

This is the connector for automatic control and monitoring of the control unit's safety systems. When this connector is not being used, please install the provided connector cover.

② Input/Output Connector CN2

This is the connector for automatic control and monitoring of the motor/spindle's systems. When this connector is not being used, please install the connector cover.

③ Motor connector

④ Cooling air output joint

Connect air hose to supply cooling air to the motor

⑤ Power Supply Voltage Selector Switch

115V or 230V power sources can be selected by use of this switch.

⑥ Air Input Joint

Supply clean, dry, regulated air for motor cooling. The air supply needs to be regulated between 0.2MPa-0.5MPa. Air consumption is 30NI/min (At 0.5MPa)

⑦ Main Power Inlet with Fuse Holder

Insert the provided power plug (Fuse 2pcs: 250V-T3.15A Order No.:U195-152)

⑧ Power switch

(2) Control Panel (Fig.2)

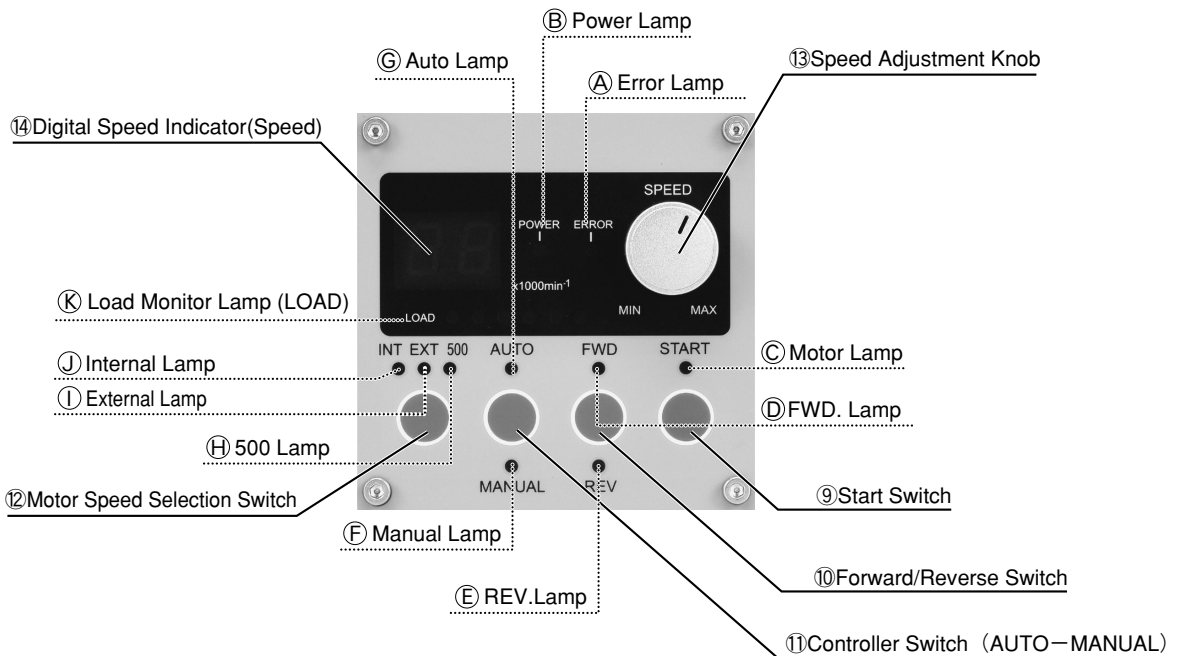

Fig.2

⑨ Start Switch

Starts and stops motor rotation

⑩ Forward/ Reverse Switch

This switch controls the direction of rotation, forward (FWD) or reverse (REV). With the cutting tool facing the operator right hand rotation (FWD) will be clockwise rotation.

⑪ Controller Switch (AUTO—MANUAL)

This switch selects motor/spindle control from the Control Panel or from an external source.

● MANUAL : Control Panel

● AUTO : External control through the input/output connector CN2②

⑫ Motor Speed Selection Switch

Select the motor speed control mode. Internal unit (INT), External (EXT), Centering (500)

⑬ Speed Adjustment Knob

Steplessly adjustable speed control. If the knob is turned clockwise, this will increase motor speed. Motor speed is adjustable: 2,000-40,000min⁻¹ (400Z), 2,000-50,000min⁻¹ (500Z) and 20,000-80,000min⁻¹ (800Z).

⑭ Digital Speed Indicator (SPEED)

Preset Speed, Actual Speed, Warning and Error Codes are displayed to 2 digits.

Ⓐ Error Lamp : When an error exists this lamp lights and the error code is shown on the digital display.

Ⓑ Power Lamp : Power Switch is in the ON position.

Ⓒ Motor Lamp : Motor is rotating (except at the minimum of speed adjustment knob)

Ⓓ FWD. Lamp : Forward rotation is counter-clockwise rotation when the cutting tool is facing the operator.

Ⓔ REV. Lamp : Reverse rotation is clockwise rotation when the cutting tool is facing the operator.

Ⓕ Manual Lamp : Manual operation

Ⓖ AUTO Lamp : Auto operation

Ⓗ 500 Lamp : 500min⁻¹ operation for centering

Ⓘ EXT Lamp : Motor Control by external signal source.

Ⓙ INT Lamp : Motor Control by front panel controls.

Ⓚ Load Monitor Lamp (LOAD) : Real time load monitoring display.

6 Diagrams

(1) Motor/Spindle Diagram(Example)

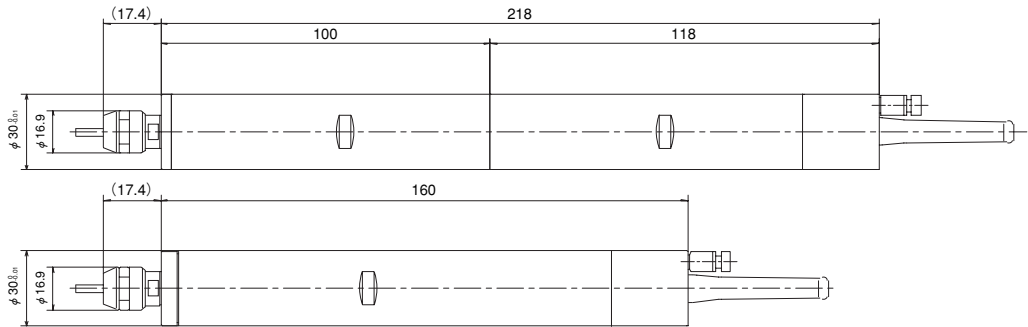

Fig.3

(2) Control Unit Diagram (ASTRO-E400Z/500Z/800Z are the same)

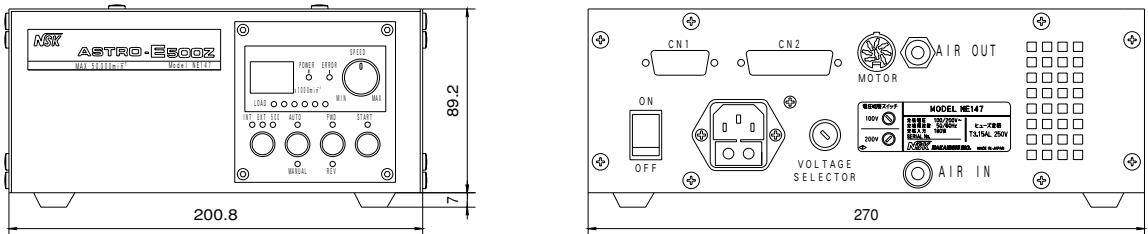

Fig.4

7 Input Voltage Switching (115V-230V)

- The Control Unit is compatible with 115V or 230V main supply voltage and is equipped with a switch for voltage selection.

⚠ CAUTION

Improper voltage settings can result in damage to internal components and injury, please use care in selecting the voltage setting and ensure that you are connecting to the proper outlet.

- Voltage Setting 115V
Set the input voltage switch to 115V
- Voltage Setting 230V
Set the input voltage switch to 230V

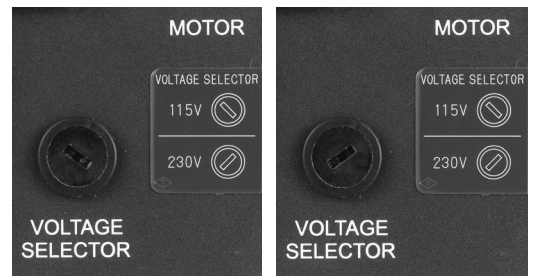

Voltage Setting 115V Voltage Setting 230V

Fig.5

8 Changing Fuses

CAUTION

- Before removing fuse, make sure that the main power switch is in the off position and the power cord is disconnected from the outlet.
- Make sure and use only the proper type and rated fuse.
 - ※ Failure to use the proper type and rated fuse will result in fire, injury, electric shock and/or product damage.

- Push on the clips on the left and right of the fuse holder, and remove the fuse holder and fuses.
- Remove the bad fuse or fuses and replace with the proper type and rated fuse.
- There is the following fuse depending on the input power source voltage.
T3.15AL(250V) Order No. : U195-152
- Replace the fuse holder containing the fuses into the fuse inlet box and make sure it snaps into place.



Pull out, pushing on the clips left and right



Replace and get back

Fig.6

9 Power Cord Connection

Insert the female plug into the main power inlet box ⑦ in the right side of the unit.

CAUTION

- Two types of power source cords are available: For 115V & 230V. Select the proper cord according to the power source being used. The type of power source cord for 230V should be specified when the system is ordered.
- Only use grounded power sources. Failure to properly ground the unit may result in electric shock, injury, fire and/or damage to the system components.

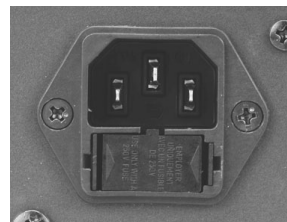

Fig.7

10 Motor Cord Connection

- Align the guide pin A on the motor plug with the key way B on the motor socket on the right side of the control unit.
- Screw in the coupling nut C of the motor plug to the motor socket D on the side of the control unit.

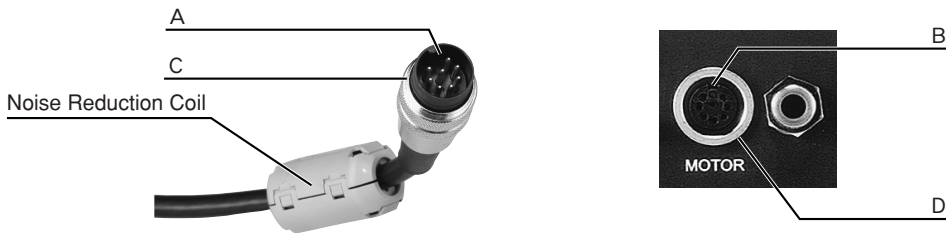

Fig.8

11 Air Hose Connection

- Insert the 4mm motor cooling air hose with $\phi 6 - \phi 4$ adaptor into the inlet joint ④ on the right side of the control unit.
- Insert the provided air hose with filter from AL-0201 into the inlet joint ⑥.
(If you are not using the AL-0201 air line kit make sure that the incoming air supply is dry, clean air.)
- Regulate air pressure between 0.2-0.5MPa. If the selector unit (NE62) is used, insert the (6mm cooling air hose into the output joint ④).
- Regulate air pressure at 0.5MPa.

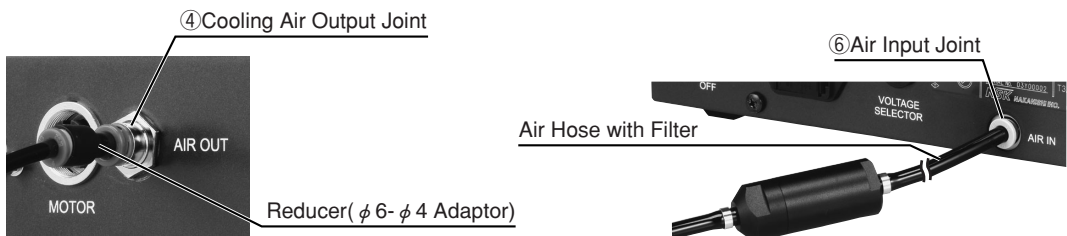

Fig.9

⚠ CAUTION

- When the air hose is to be removed, push on the outer ring of the quick connector on ④ Cooling Air Output Joint or ⑥ Air Input Joint. Trying to force this connector loose will break the connector.
- The cooling air provides two functions, to cool the electric motor and to protect the spindle from contaminants. If the main power switch ② is in the OFF position do not subject the spindle to direct coolant spray or use in dusty areas.
- Do not bend the air hose in any sharp bends or pull on the hose, this can cause the hose to break, cut off the air supply or weaken the hose over time resulting in deterioration of the motor and spindle.

12 Connecting the Motor and Spindle

Align the threads at the front end of the motor and the rear end of the spindle and turn the spindle clockwise. If the motor's drive shaft and the spindle's drive dog do not align properly you will only be able to turn the spindle about 2 turns. **DO NOT FORCE.** Turn the spindle back, counterclockwise, slightly and rotate the spindle by hand to engage the drive assemblies and then screw them together tightly and fasten with the provided wrenches.

! CAUTION

Make sure your hands and all interlocking parts of the spindle and motor are clean before connecting the motor to the spindle to prevent contamination.

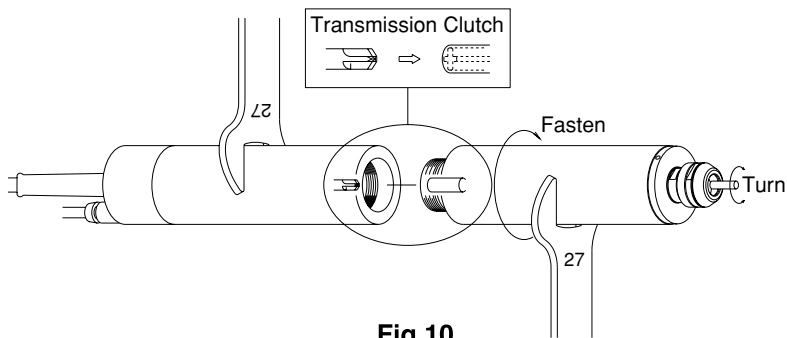

Fig.10

13 Changing Tools

- ① Set the provided 12mm spanner (wrench) on the spindle.
- ② Place the provided 14mm spanner (wrench) on the chuck nut, and turn it counterclockwise to loosen the collet and remove the tool. (The first turn will loosen the chuck nut, but the tool will not release and turning will become stiff. Keep turning through the stiffness and the collet will open.)
- ③ Insert the new tool and tighten the collet by turning clockwise.

! Caution

Never install a collet into the spindle quill without first assembling it in the chuck nut. Do not tighten the collet without mounting a cutting tool or dummy bar as this will result in damage to the collet, spindle and collet nut and make it impossible to remove the collet.

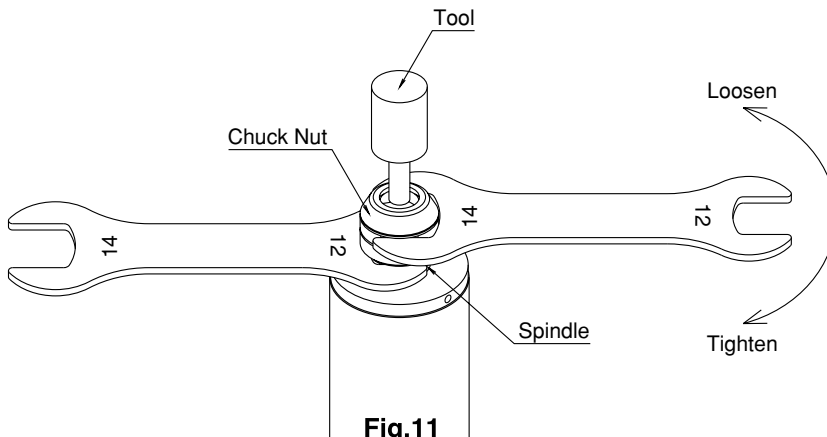

Fig.11

14 Replacing the Collet

- ① Remove the tool according to the “Changing Cutting Tools” procedure above and remove chuck nut assembly. (Fig.12)
- ② The collet and chuck nut are held together by a groove in the collet and a flange in the chuck nut. To remove the collet hold the chuck nut in one hand and push diagonally down on the collet. The collet should pop out. (Fig.12)
- ③ The new collet is installed in the chuck nut by positioning the collet in the chuck nut and pressing down on a flat surface. (Fig.13)

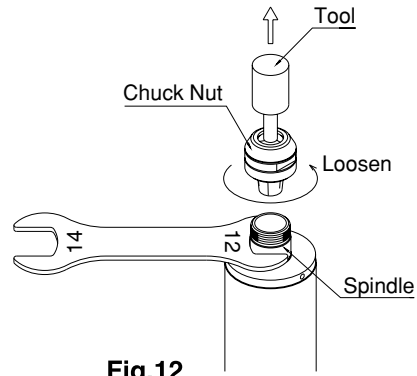

Fig.12

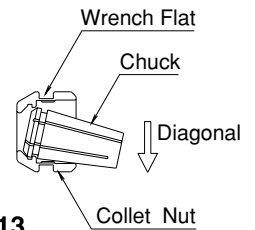

Fig.13

15 Fixturing the Motor and Spindle

The installation shown in **Fig.14** is the recommended fixturing method. If this is not possible, install as shown in **Fig.15**. Do not use set screws directly in contact with the motor or spindle body as shown in **Fig.16**, this will result in damage to the housing and internal components. When the spindle is mounted, take care not to fixture over the bearings because this will result in bearing damage.

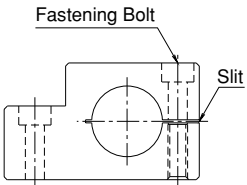
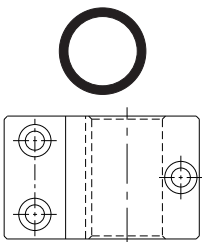

Fig.14

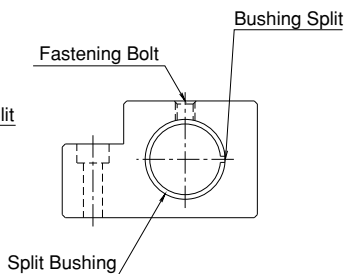
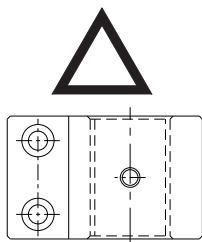

Fig.15

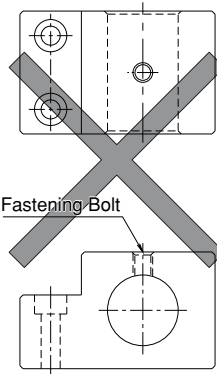
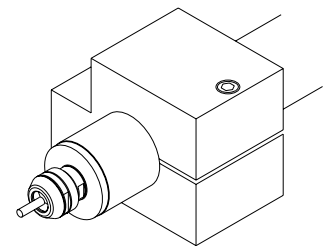

Fig.16



16 Operation Procedures

●MANUAL Control mode (Fig.17, 18)

- (1) Turn the power switch on ⑧.(The green power source lamp ③ lights)
- (2) Push the control switch ⑪ to light MANUAL lamp ⑥.
- (3) Push the Motor Speed Selection Switch ⑫ (INT • EXT • 500) to light Internal Lamp (INT).
- (4) Push the FWD/REV.Switch⑩ to light FWD./REV. Lamp (Forward Rotation Lamp ④ or Reverse Rotation Lamp ⑤ .)
- (5) Turn the Speed Adjustment Knob fully to the left.
- (6) When utilizing centering mode, push Motor Speed Selection Switch ⑫ to light 500 lamp ④. And push start switch ⑨ to rotate at 500min⁻¹.
- (7) Push the START switch ⑨ and check that the Motor Lamp ③ lights. Adjust the Speed Adjustment Knob by turning clockwise to select the desired motor speed. The display on the Digital Speed Indicator ⑭ will display actual motor speed. The Digital Speed Indicator displays speed in 2-digits: 1-40 (40 equals the max. motor speed 40,000 for 400Z, 50 equals the max. motor speed 50,000 for 500Z, 80 equals the max. motor speed 80,000 for 800Z)
(The motor speed display 1 means 1,000 min⁻¹.)
- (8) Pushing the Start Switch a second time will extinguish the Motor Lamp and the motor will stop.
(Reset the Speed Adjustment Knob ⑬ to the minimum speed setting, and restart the ASTRO-E400Z/500Z/800Z according to the procedure mentioned in step ⑦ of this section)

CAUTION

If an excessive load is applied to the motor and spindle, the Error Lamp ① will light and the protection system will stop the motor to protect the motor. After reducing the load, the protect circuit can be reset. Push Start Switch ⑨ the Error Lamp ① will extinguish and protection circuit will be released

●AUTO Control mode (Fig.17,18)

- (1) Attach cable connectors to Input/Output connector CN1 • CN2 (① • ②).
(Cable connector type:Dsub25, Dsub15 and M2.6 Attachment Screw are not supplied with the system and need to be purchased separately.)
- (2) Turn the Power Switch on ⑧ (The green power source lamp ③ will light.)
- (3) Push Control Switch⑪ to light AUTO Lamp ⑦. Push the Motor Speed Selection Switch ⑫ to light the EXT Control Lamp ① to set external control mode.
Refer to **External Input/Output Connector Specifications**, for proper connections.
In Auto control mode motor speed can be controlled either by the Speed Adjustment knob or an external signal. If you desire the Speed Adjustment knob control use the ⑫ Motor Speed Selection Switch to select INT.
If you desire external signal control select EXT.
- (4) The motor rotation direction cannot be changed by Rotation Direction Input Signal (DIR_IN), while the motor is rotating.

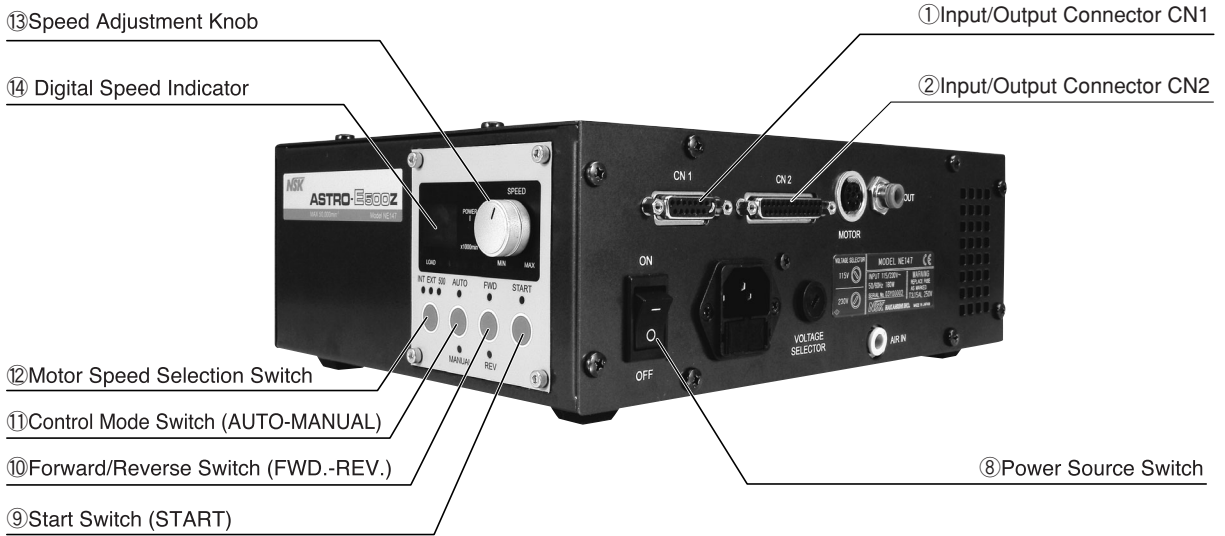

Fig.17

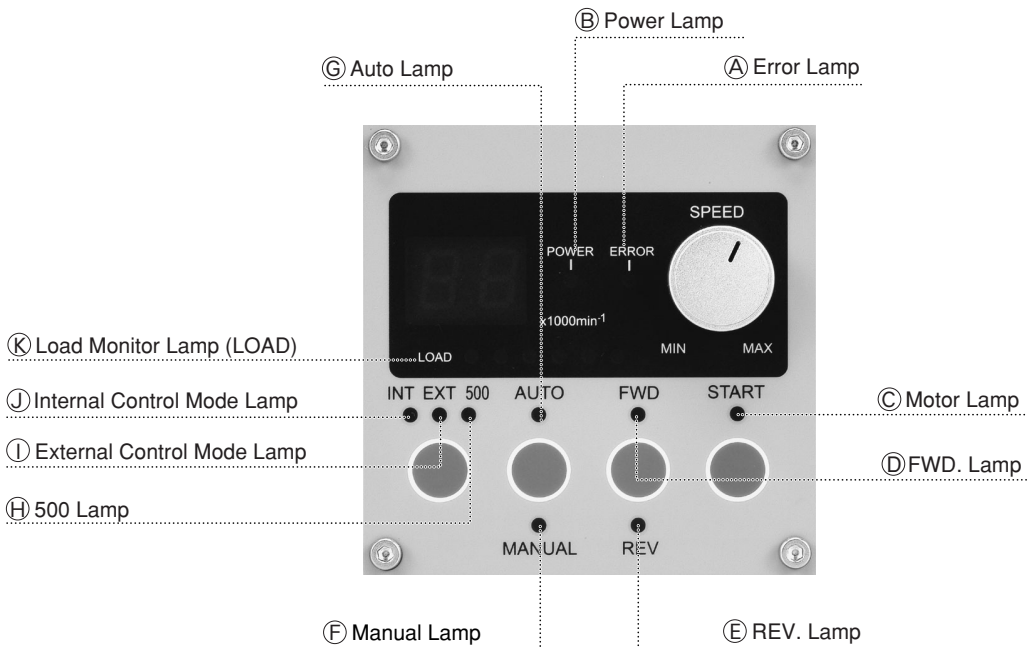

Fig.18

17 External Input/Output Control Signal Specifications

(1) External Input/Output Connector CN1

① External Input/Output Connector CN1 Control Signal Details

Pin No.	Pin Name	Description	Input/Output	Signal	Function
1	EMG-IN+	Emergency Stop Signal(+)	Input	Open(0V): Emergency Stop	Open/Closed circuit with Pin9. When the circuit is open the motor is stopped and the Emergency Stop System is active. When the circuit is closed the system is in normal operation.
2	CON ERR+	Motor disconnect	Output	OFF(Open): Disconnect	Signal to show motor disconnection. When the circuit between pins2 and 10 is open the motor is disconnected.
3	SAFE - 1A	Safety Relay Contact 1A Safety Relay Circuit A Contact 1	Output	ON(Closed): Emergency Stop.	When there is continuity between PIN3 and PIN11 ON(Closed) Safety Relay is OFF(System Stopped), no continuity Safety Relay is OFF(Open) Normal Operation.
4	SAFE - 1B	Safety Relay Contact 1B Safety Relay Circuit B Contact 1	Output	ON(Closed): Emergency Stop.	When there is continuity between PIN4 and PIN12 ON(Closed) Safety Relay is OFF(System Stopped), no continuity Safety Relay is OFF(Open) Normal Operation.
5	AUTO+	AUTO Mode Signal(+)	Output	AUTO Mode Output	When AUTO mode is being used,output transistor is ON(closed).
6	PWON+	Control Unit Power Source Detector(+)	Output	Power ON Output	When incoming power supply is active, output transistor is ON(closed).
7	—	—	—	—	NOT Used
8	—	—	—	—	NOT Used
9	EMG-IN-	Emergency Stop Signal(-)	Input	Open(0V): Emergency Stop	When emergent stopping, disconnect the pin to open the relay contact
10	CON ERR-	Motor disconnect	Output	OFF(Open): Disconnect	Open/Closed circuit with Pin9. When the circuit is open the motor is stopped and the Emergency Stop System is active. When the circuit is closed the system is in normal operation.
11	SAFE - 2A	Safety Relay Contact 2A Safety Relay Circuit A Contact 2	Output	ON(Closed): Emergent Stop	When there is continuity between PIN3 and PIN11 ON(Closed) Safety Relay is OFF(System Stopped), no continuity Safety Relay is OFF(Open) Normal Operation.
12	SAFE - 2B	Safety Relay Contact 2B Safety Relay Circuit B Contact 2	Output	ON(Closed): Emergency Stop	When there is continuity between PIN4 and PIN12 ON(Closed) Safety Relay is OFF(System Stopped), no continuity Safety Relay is OFF(Open) Normal Operation.
13	AUTO-	AUTO Mode Signal(-)	Output	AUTO Mode Output	When AUTO mode is being used,output transistor is ON(closed).
14	PWON-	Control Unit Power Source Detector(-)	Output	Power ON Output	When incoming power supply is active, output transistor is ON(closed).
15	—	—	—	—	NOT Used

② External Input/Output Circuit

(1) EMG-IN (Emergency Stop Input) (CN1:Pin1, Pin9)

When the ASTRO-E400Z/500Z/800Z is shipped from the factory, a shorting pin is installed between pins 1 & 9.

Before the “Emergency Stop Input” can be used the shorting pin must be removed.

When the circuit between Pins 1 and 9 is completed, the safety relay is closed and power is supplied to the motor. When the circuit between Pins1 and 9 is open, the relay contacts are opened and the power supply to the motor is interrupted. (**Fig.19**) If Pins 1 and 9 are disconnected power can't be supplied to the motor because the safety relay contacts are not closed.

When the Emergency Stop Signal system is to be connected to a machine's interlock safety system remove the shorting pin shown in **Fig 24** and connect this line to the interlock safety switch.

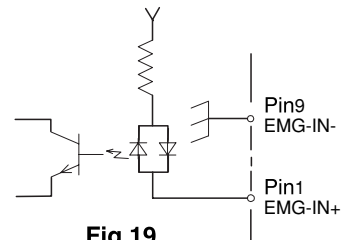

Fig.19

(2) CON ERR (Motor Cord Disconnect Output) (CN1:Pin2, Pin10)

When the motor cord is disconnected or the AC Power Source is disconnected or shut off, the Transistor Output of the Photo Coupler is OFF. When the motor cord is connected and the AC Power Source is connected and the Power Switch is ON, the Transistor Output is ON.

(**Fig.20**) If an E3 error occurs while the motor is rotating the motor will stop and the Transistor Output will be ON. (if a motor cord is connected) (The max. rating of transistor is $V_{CE0}=50V$, $I_c=50mA$, $P_c=100mW$. Please use at less than the maximum rating)

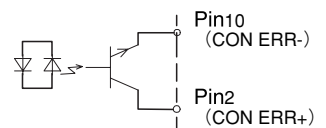

Fig.20

(3) SAFE A/B PIN No. 3, 4, 11, 12)

- The Safety Relay will be ON or OFF depending on the state of the Emergency Stop Signal PINs 1 and 9.
- When there is continuity between PIN 3(SAFE-1A) and PIN 11(SAFE-1B) or between PIN 4 (SAFE-2A) and PIN 12 (SAFE-2B) the motor is off. If there is no continuity between these pairs of pins then the system is operating normally.
- If the Emergency Stop Signal is OFF (Open) the Safety Relay will be OFF(Open) and the motor power will be interrupted and the motor will stop.
- If the 'a' contacts of the Safety Relay are welded together by an over load or short circuit the 'b' contacts' separation is maintained with more than 0.5mm spacing by the relay's recoil mechanism

①CN1 Connector Rating-Relay Contact Rating

Current Rating	3A AC · DC
Voltage Rating	250VAC · DC

②Relay Contact Rating (At resistance load $\text{COS } \phi = 1$)

• Max. Current	6A
• Load Rating	AC250V · DC30V 6A
• Max. Voltage	AC250V DC125V
• Current Rating	6A

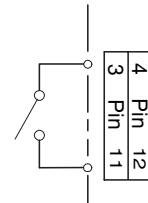

Fig.21

(4) AUTO (AUTO MODE Signal) (CN1: Pin5, Pin13)

When Control Switch is set to AUTO MODE, Pins 5 and 13 are ON(Closed).

When Control Switch is set to MANUAL MODE, Pins 5 and 13 are OFF (Opened).(Fig.22)

(The max. rating of transistor is $V_{CE0}=50V$, $I_c=50mA$, $P_c=100mW$. Please use at less than the maximum rating)

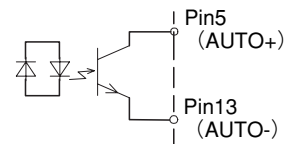

Fig.22

(5) PWON (Control Unit Power Source Detector) (CN1: Pin6, Pin14)

When the control unit's power source is connected and the Power Switch is ON, Output Transistor is ON (Closed).

(Fig.23) (The max. rating of transistor is $V_{CE0}=50V$, $I_c=50mA$, $P_c=100mW$. Please use at less than the maximum rating)

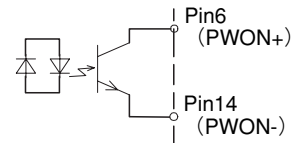

Fig.23

(6) External Input/Output Connector CN1 Pin Arrangement (Fig.24)

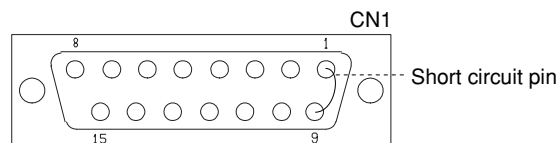

Fig.24

CAUTION

When the ASTRO-E400Z/500Z/800Z is shipped from the factory, a shorting pin is installed between pins 1 & 9. If this pin is not installed the Safety Relay will be open and the power supply to the motor will be interrupted. When Connector CN1 is not used, the shorting pin must be installed. When Connector CN1 is being used the shorting pin should be removed and the connections made according to the description above.

(2) External Input/Output Connector CN2

① External Input/Output Connector CN2 Signal Details

Pin No.	Pin Name	Description	Input/Output	Signal	Function
1	COM	Common Input Signal Source	Input	Common	Common Signal(DIR_IN,START)
2	DIR_IN	Rotation Direction Setting Signal	Input	ON(24V); Reversed Rotation	24VDC NO Dipole Moment Input to set Rotation Direction.
3	5VDC	Base Bias	Input	5VDC	Photo Coupler Bias Power Source
4	—	—	—	—	Not Used
5	—	—	—	—	Not Used
6	STOP(+)	Stop Rotating	output	OFF(OPEN):Stop	While motor is rotated, Photo Coupler Transistor is ON. When motor is stopped, Photo Coupler Transistor is OFF.
7	—	—	—	—	Not Used
8	ERR(+)	Trip Signal	output	ON(Closed):Trip	When Errors Occur(Overload , Motor Cord is disconnected)
9	—	—	—	—	Not Used
10	GND1	Analog Power Source Ground	output	Internal GND	Unit Internal Ground (+10V Ground)
11	VCC	Power Source for Analog Signal	output	10VDC	Speed Direction Voltage(VR) Signal Power Source. Output +10VDC.
12	LOAD(+)	LOAD Signal	output	0-15V Output	Load Signal Output (0-15VDC)
13	LOAD(-)	LOAD Signal(Earth)	output	GND	GND(LOAD)
14	START	Rotation Start Command Signal	Input	ON(24V):Rotation	Input 24VDC to rotate the motor.
15	—	—	—	—	Not Used
16	—	—	—	—	Not Used
17	—	—	—	—	Not Used
18	- COM	Trip Signal	output	ON(24V):Trip	Common for (Pins 6,8,19)
19	PULSE	Rotation Pulse	—	24Pulse/Rotation	Rotation Pulse(Photo Coupler Output TTL Level) 24 Pulse Output/ 1 revolution Output/ 1 rotation
20	—	—	—	—	Not Used
21	—	—	—	—	Not Used
22	—	—	—	—	Not Used
23	VR	Motor Speed Control Voltage	Input	0-10VDC	Rotation Speed (0V-10VDC Input) At 10V, 50,000min ⁻¹ or 80,000 min ⁻¹
24	—	—	—	—	Not Used
25	SPEED_V	Motor Speed Monitor Voltage	output	0-8VDC	When motor is rotated, Motor Speed can be monitored. Output voltage is proportional to motor speed.

② External Input/Output Circuit

(1) DIR_IN (Rotation Direction Setting Signal) and START (Rotation Start Command Signal) (CN2: Pin1,Pin2, Pin14)

Pin 1 : Common for Pin 2 & Pin 14

Pin 2 : When +24V DC is supplied to the Rotation Direction Setting Signal (DIR_IN), Motor rotates counterclockwise. When Pin2 is disconnected or voltage is not supplied, Motor rotates clockwise.

Pin14 : When +24V DC is supplied to the Rotation Start Command Signal (START), the motor starts rotating, If 0V DC is supplied or if the line is disconnected the motor stops.

Com can be either (+) or (-), if using (+) common use (-) on Pins 2 and 14. **(Fig.25)**

24V (10mA×2 circuits) is needed for power source.

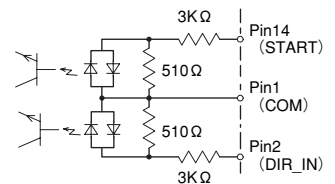

Fig.25

- (2) VR(Motor Speed Control Voltage) and VCC (+DC10V Power Source for Analog Signal)(CN2:Pin10,Pin11,Pin23)

Pin10:Common for Pin11 & Pin23

Pin23:Input Motor Speed Control Voltage (+0-10V DC) on VR (Motor Speed Control Voltage)(Fig.26)

Pin11:+10V DC is output on VCC (+10V DC Power Source for Analog Signal). Pin11 can be used as a source for Motor Speed Control Voltage and Motor Speed Rotation can be varied by varying this voltage. Attach a 50KΩ Potentiometer.(Refer to Fig.26)

By supplying +10V DC, Motor Speed can be varied up to 40,000min⁻¹(NE147-400)・50,000min⁻¹(NE147) or 80,000min⁻¹(NE147-800) (Fig.26).

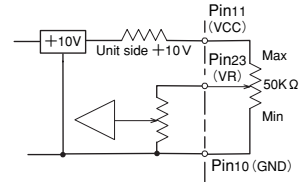

Fig.26

- (3) ERR (Trip Signal Output) (CN2 : Pin8, Pin18)
Photo Coupler isolated Transistor Output . (Fig.27)
(Max. Rating of Transistor is V_{CEO}=50V, I_c=50mA,P_c=100mW) Please use at less than the maximum rating

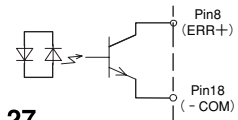
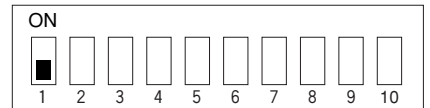
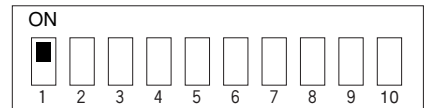

Fig.27

For ASTRO-E400/500 (NE52), the trip signal transistor is ON when a trip signal is output. The Error Output Code from NE147-400 NE147, NE147-800 needs to be reversed to maintain the compatibility with NE52, use the following process.

- ①Turn the Power Switch OFF
- ②Remove the top cover from the control unit.
- ③Turn off No.1 dip switch. DO NOT change any other dip switches.(Fig.28)
- ④Reinstall the top cover.

At factory shipment



In case the error output theory is reversed

Fig.28

- (4) LOAD (Load Signal) (CN2: Pin12, Pin13)
DC Voltage is output: +0~15V DC in proportion to Motor Load.(Fig.29)

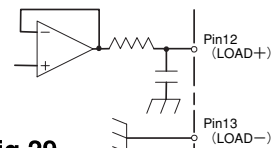

Fig.29

CAUTION

Be careful when connecting outputs to other electric equipment, because (-) Voltage may be output. (Fig.29)

- (5) STOP (Rotation Stop) (CN2:Pin6, Pin18)
Photo Coupler isolated Transistor Output (Fig.30)
When Motor is stopped, Transistor is OFF.
The Max. Rating of Transistor is V_{CEO}=50V, I_c=50mA, P_c=100mW.
Please use at less than the maximum rating.

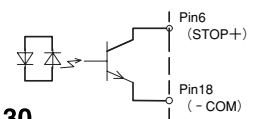

Fig.30

CAUTION

The transistor will switch ON/OFF repeatedly when motor speed is between 400-1,000rpm take care when designing control software. Especially, when ON/OFF is cycled rapidly.

(6) SPEED_V (Motor Speed Monitor Voltage) (CN2:Pin25, Pin13)

The output is 1V DC= 10,000 min⁻¹with. When these pins are connected to an Analog Voltage Gauge, Motor Speed can be measured. (Fig.31)

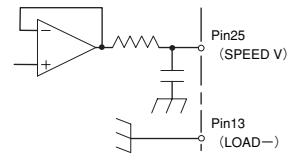

Fig.31

(7) PULSE (Rotation Pulse) (CN2:Pin3, Pin18, Pin19)

TTL Level signal, 24 pulse/rpm. This signal can be used for highly accurate monitoring of motor speed. (Fig.32)

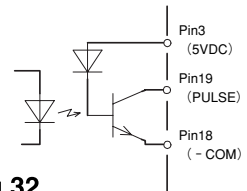

Fig.32

(8) External Input/Output Connector CN2 Pin Arrangement (Fig.33)

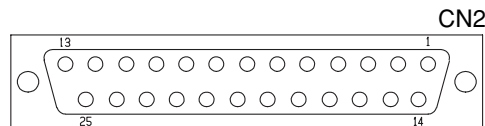

Fig.33

(9) When CN1 or CN2 is not used, please attach the provided connector cover to the unused connector.

(10) Refer to Table 1 for cross reference information between the External Input- Output Terminal of NE52 & CN2 of NE147-400/NE147/ NE147-800.

Table 1

NE147-400 NE147 NE147-800	11 (VCC)	23 (VR)	10 (GND1)	2 (DIR-IN)	1 (COM)	14 (START)	8 (ERR+)	18 (-COM)	6 (STOP+)	18 (-COM)	12 (LOAD+)	13 (LOAD-)
NE52	10V	+ (SPEED)	- (SPEED)	R/L	COM	ON/OFF	+ (TRIP)	- (TRIP)	+ AT2 (TURN)	- AT3 (CUR)	+ AT3 (CUR)	- AT3 (CUR)

※VCC-Power Source for Analog Signal.

※For ERR (Trip Signal Output), default error output code is reversed.

(3) External Input/Output Connector Specifications

●External Input/Output Connector CN1

- Plug Part Number: XM2A-1501 OMRON (or other similar high-quality product)
- Cover Part Number: XM2S-1511 OMRON (or other similar high-quality product)
- Cable Part Number: (Connector with 2m Cable)
NEDJ-P-A-15-2.0 Misumi Corp. or other similar high-quality product

●External Input/Output Connector CN2

- Plug Part Number: XM2A-2501 OMRON (or other similar high-quality product)
- Cover Part Number: XM2S-2511 OMRON (or other similar high-quality product)
- Cable Part Number: (Connector with 2m cable)
NEDJ-P-A-25-2.0 Misumi Corp. or other similar high-quality product

Note: Please purchase the products specified above separately from local suppliers.

18 Protection System

(1) Operating Condition Monitoring

Constant monitoring of the control unit, motor, spindle and the pressure of the cooling air to detect undesired operating conditions. This system helps prevent errors that will result in unsafe operating conditions.

- Motor is stopped.
- ERROR Lamp (ERROR) (A) will flash.
- The error Codes (listed in Table1) will be displayed on the Digital Speed Indicator (14).
- Trip Signal is output to External Input/Output Connector CN2: Pin8(ERR).

(2) ERROR Reset

There are 2 methods for resetting the control unit after an ERROR.

- Manual mode, push START Switch (9) on the front panel to reset.
- Auto mode, switch off (Open) Pin14 (START) of External Input/Output Connector CN2 to reset →ON (Closed) Start to rotate.

Table 2

Display Code	Detector Function	Error
E1	Excessive Current	Excessive Current to Motor.
E3	Motor Sensor	Motor Connector is disconnected.
E4	Thermal Protection	Over 90°C
E7	Low Air Pressure	Air pressure for motor cooling is too low.
E8	Excessive Load	Continuous excessive load.
EA	External Start UP Error	AUTO control mode, Motor Speed Control Voltage has been supplied before Power Source is ON.
EE	Emergency Stop Error	Input Emergency Stop Signal.
EH	Over Speed	Excessive Motor Speed(45,000min ⁻¹ (400Z) • 55,000min ⁻¹ (500Z) • 85,000min ⁻¹ (800Z))

(3) Over Load Characteristics

6 LED load monitor allows the operator to assess load conditions easily. Continuous Duty (3 Green LEDs), Intermittent Duty (2 Yellow LEDs), Overload (1 Red LED). If the RED LED is lit for more than 15 seconds, the overload protection system will activate and interrupt power to the motor.

When using ASTRO-E800Z with no load, LOAD Monitor Lamp (Green LED) may flash. This is not an error. (EM801, EM805, NR3080, NRA5080)

- Error Code “E8” is displayed on Motor Speed Indicator (SPEED) (14).
- Error Lamp (ERROR) (A) will flash.
- Error Signal is output to Pin8 (ERR) of External Input/Output Connector CN2.

CAUTION

If the system is operated in overload repeatedly and for a long period of time, this will cause damage to ASTRO-E400Z/500Z/800Z, due to overheating of the control unit, motor and spindle.

Recommended usage under load is with 3 or less Green LEDs lit: Continuous Operation Use Area) as much as possible.

19 Break-In Procedure

The ASTRO-E400Z/500Z/800Z is a high-precision, high-speed motor-spindle, the following procedure must be followed to ensure proper operation and longevity.

During transportation, storage or installation the grease inside the bearings will settle. If the motor-spindle is suddenly run at high-speed excessive heat will cause bearing damage. After installation, repair, initial operation, or long periods of non operation please follow the break-in procedure detailed in Table 3 for Astro-E500Z and Table 4 for Astro-E800Z

And as for ASTRO-E400Z(40,000min⁻¹), please follow the break-in procedure(steps1,2,3) detailed in Table3

Table 3

Steps	1	2	3	4
min ⁻¹ (rpm)	15,000	30,000	40,000	50,000
Running Time	15Min.	10Min.	10Min. (15Min.for ASTRO-E400Z)	15Min.
Items to Check	No Abnormal Noises	Spindle Housing no hotter than 20 C. If hotter than 20 C check installation and restart Break-In procedure.	Spindle Housing no hotter than 20 C. If hotter than 20 C stop for at least 20 minutes, check installation and restart Break-In procedure.	Spindle Housing less than 20C.

Table 4

Steps	1	2	3	4
min ⁻¹ (rpm)	10,000	30,000	50,000	80,000
Running Time	5Min.	2Min.	2Min.	2Min.
Items to Check	No abnormal noises or vibration. Check lubricator oil supply.	Spindle Housing no hotter than 20 C. If hotter than 20 C stop for at least 20 minutes, check installation and restart Break-In procedure.	Spindle Housing no hotter than 20 C. If hotter than 20 C stop for at least 20 minutes, check installation and restart Break-In procedure.	Spindle Housing less than 20C.

20 Cutting tool cautions

(1) The proper surface speed for vitrified grindstones is 600-1800m/min.



CAUTION

Do not exceed a surface speed of 2,000m/min for grinding.

$$\text{Surface Speed (m/min)} = \frac{3.14 \times \text{Diameter (mm)} \times \text{rotation speed (min}^{-1}\text{)}}{1000}$$

(2) Do not exceed 13mm overhang for mounted grindstones. In case overhang must exceed 13mm reduce the motor speed in accordance with Fig.34 and Table 5.

Table 5.Overhang and Speed

Overhang (mm)	Max. Operating Speed (min ⁻¹)
20	N × 0.5
25	N × 0.3
50	N × 0.1

※ N=Max. operating speed at 13mm overhang.

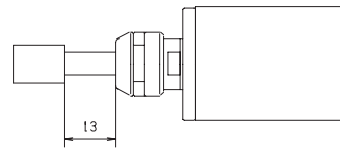

Fig.34

(3) Do not use tools with bent or broken shanks, cracks or excessive runout.

(4) Dress the grindstone prior to use.

(5) For grinding the maximum depth of cut should not exceed 0.01mm radially or axially. Reciprocate the tool several times after each in feed step.

(6) Always operate tools within the tool manufacturer's recommended speed limits. Use of a tool outside of the manufacturer's recommended speed limits could cause damage to the spindle and injury to the operator.

(7) Keep the tool shank and collet clean. If contaminants are left in the collet, they can cause excessive runout and damage the tool and spindle.

(8) Do not drop or hit spindle.

21 Optional Parts

There are several optional parts available depending on how you need to configure or mount the control unit. Please order by Catalog Number.

(1) Bracket

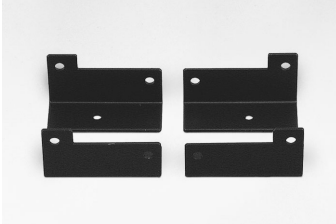

Horizontal Mounting Brackets (4pcs./set)
Model BRB-4 Code No.8410 (ASE8410 in U.S.A.)

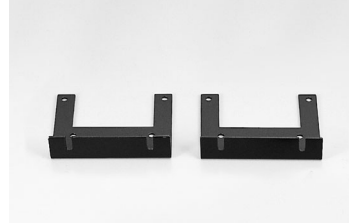

Vertical Mounting Brackets (2 pcs./set)
Model BRR-2 Code No.8412(ASE8412 in U.S.A.)

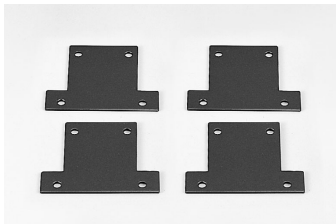

Suspended Mounting Brackets(4pcs./set)
Model BRC-4 Code No.8413(ASE8413 in U.S.A.)

(2) Mounting Brackets

- 3 Mounting Bracket styles are available.
Horizontal Mounting Brackets (**Fig.35**)
Vertical Mounting Brackets (**Fig.36**)
Suspended Mounting Brackets (**Fig.37**)

CAUTION

Make sure to use the complete bracket set. A bracket is required to support all areas of the control unit. Do not substitute screws, use the screws you remove from the unit in the same place as they were removed from.

CAUTION

**Never install the unit in an inclined or inverted position. This manner of installation will cause heat buildup, or damage to the control unit.
Never install the unit in such a manner as to block the air vents on the side of the control unit. This manner of installation will cause heat buildup and damage to the internal components of the control unit.**

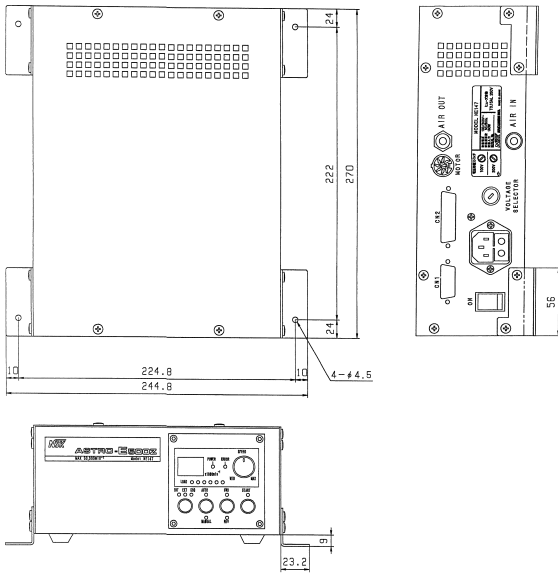

Fig.35 Horizontal Mounting Brackets

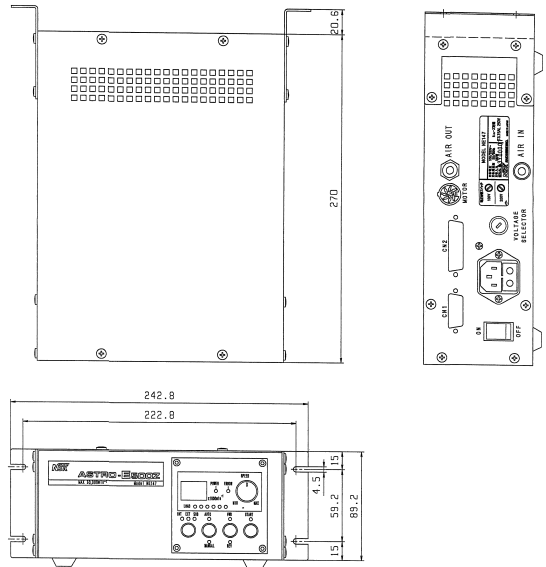

Fig.36 Vertical Mounting Brackets

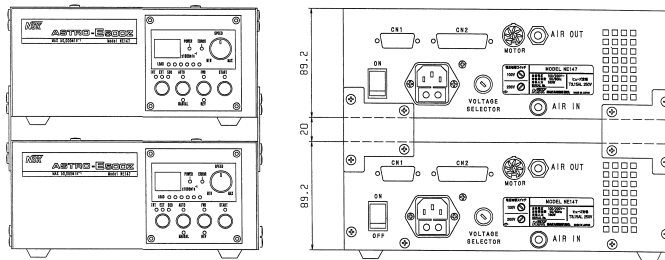

Fig.37 Suspended Mounting Brackets

When the following optional parts are used, refer to operation manual.



Power Cord Retention Bracket
Model AC-STP2 Cord No.8408
(For 200v · 115v · 230v)



Control Panel Extension Cord (Assembly : 4m (13ft.))
Model PEX-4 Code No.8411 (ASE8411 in U.S.A.)



AC Power Plug
Model AC-SO3 Code. No.8414 (ASE8414 in U.S.A.)

※This is the plug only to connect to the control unit's Main Power Inlet.
This plug does not include a power cord. It is intended to be used with a standard 3 conductor cable. The cable length can be cut to fit your specific installation. Please refer to the Minimum gage for cord chart on page 1 of this manual to determine the proper cord gage for the length and voltage required.
Caution-do not attempt to make any electrical connections without consulting with a qualified electrician.

22 Trouble Shooting

Trouble	Check Points	Cause	Inspect/Corrective Action
Motor Does Not Run	Power Switch is on, but power lamp does not light.	No voltage in Power Source Line. Power Source Plug is disconnected or not connected firmly.	Use an approved tester to test voltage at the power outlet. Consult with a licensed electrician prior to any electrical work or checks. Insert Power Source Plug into outlet with firmly. Check the power cable connection at the control unit.
		Blown Fuse.	Refer to section 8 Change Fuse, check if fuse (250V-T3.15AL) is blown. Even if only one fuse is blown, both fuses need to be changed together.
		Thermal Shutdown.	Check the temperature of the bottom of unit. If the bottom of the unit is very hot the thermal protection system has shut off motor power. Let the unit sit for 20 minutes and restart the system.
Motor does not Run (Power Lamp is lit)	After pushing the Start button, nothing happens. Auto Mode-motor does not rotate with +24V DC on the Start line.	Error lamp is lit. After resetting system, Error lamp is not lit with motor Off, but Error lamp lites again when motor is switched On.	If E1, E8 or EH Error Code is displayed correct the cause of the error and reset the system.
		Error lamp cannot be shut off.	If E3, E4, E7, EA or EE Error code is displayed, check the related system and correct the cause of the error. Reset the system. If E4 is displayed wait 20 minutes before restarting the system.
Motor does not Run (Power Lamp is lit) Auto Mode is set	Can't control speed form external signal.	Motor Speed Selection Switch is set to INT or 500	Check the Motor Speed Selection Switch and set to EXT.
Motor does not Run (Power Lamp is lit) Auto Modes is set.	Motor does not rotate.	No voltage (+24V DC) on Start line.	Check +24V DC power supply and connecting wires.
	Can't Rotate in reverse.	No voltage (+24V DC) on DIR_IN line.	
	Can't control speed from external signal.	No voltage on VR line.	Check if +0-10V DC between Pin10 and Pin23 on CN2. If no voltage the problem is external to the NSK control unit.
	Can't reset error.	EA Error.	EA Error cannot be reset by recycling the Start Switch. Shut down the Start signal on CN2 and cycle the Power Switch OFF and ON.
EE Error.		Check shorting pin on CN1 if not using Emergency Stop System. If using Emergency Stop System, check continuity of connections to machine's safety systems.	

※Specifications may be changed without notice.

NAKANISHI INC. 
www.nakanishi-inc.com

700 Shimohinata Kanuma-shi
Tochigi 322-8666,
Japan

NSK Europe GmbH 
www.nsk-europe.de

Elly-Beinhorn-Strasse 8
65760 Eschborn,
Germany

NSK America Corp
www.nskamericacorp.com

1800 Global Parkway
Hoffman Estates, IL 60192,
USA