

Air Bearing Spindle ABS-800

OPERATION MANUAL

OM-K0391E Rev.A

Thank you for purchasing ABS-800, Air Bearing Spindle.
Read this operation manual carefully before use to ensure years of trouble-free operation.

1 Cautions for handling and operation

- Read these cautions carefully and only use in the manner intended.
- Safety instructions are intended to avoid potential hazards that could result in personal injury or damage to the device. Safety instructions are classified as follows in accordance with the seriousness of the risk.

Class	Degree of Risk
WARNING	A hazard that could result in bodily injury or damage to the device if the safety instructions are not followed.
CAUTION	A hazard that could result in light or moderate bodily injury or damage to the device if the safety instructions are not followed.

WARNING in Handling

- The ABS-800 is not designed for hand use. Install it on a machine like a special purpose machine or an NC lathe.
- Do not touch the spindle while it is running.
- Wear safety glasses, dust mask and hearing protection, and use a protective cover around the spindle whenever spindle is operating.
- Check the chuck tightness before each use.
- Do not apply excessive force. This may cause tool's slippage or tool's damage.
- Do not use bent, broken, chipped, out of round or sub-standard tools. They can shatter or explode, and may cause injury.

CAUTION

- Always supply clean, dry air to the bearing surfaces even when the spindle is not being rotated.
- Never rotate the spindle without supplying clean, dry air to the bearing surfaces. This will cause damage to the spindle or the air bearing.
- Do not drop or hit the spindle because the shock can damage the internal components.
- Always drain off the air filter to avoid rust or damage to the spindle.
- Do not strike the spindle or disassemble it.
- Always clean the tool shank before installing in the spindle.
- Always clean the chuck. If ground particles or metal chips stick to the inside of spindle or the chuck, this will cause damage to the chuck or spindle and loss of precision.
- Do not over tighten the chuck. This may cause spindle damage.
- Select suitable products or tools for the applications. Do not exceed the capabilities of the spindles or cutting tools.
- Stop working immediately when abnormal rotations or unusual vibration are observed.
- Use only tools with shank diameter tolerance similar to the chuck I.D. tolerance.
- If the spindle has not been used for a long period of time, check if the spindle floats on an even cushion of compressed air. And confirm that the spindle generates almost no vibration when the motor speed is maximum.
- Check if the air pressure is appropriate and if tools, chucks or air hose are damaged before working.

2 Features

- The use of an air bearing and high precision collet makes this spindle perfect for ultra-precision machining applications. It is designed for internal grinding of small bores of ceramics or ultra hard alloys.
- Installation to a special purpose machine is made easy by using its outside diameter of $\phi 50\text{mm}$.
- Use of air bearings makes oil mist supply to the spindle unnecessary assuring a long maintenance-free life.
- Various sizes of collet chucks are available 0.5mm-4.0mm. Standard collet chuck is 3.0mm.

3 Specifications & Dimensions

3-1 Specifications

Speed	80,000min ⁻¹
Spindle Accuracy	Within 1 μm
Appropriate Air Pressure	Turbine: 0.3—0.5MPa Bearing: 0.5MPa
Bearing Load Capacity	Radial: Less than 8N(0.5MPa) Thrust: Less than 14N(0.5MPa)
Air Consumption	For Air Bearing : 65 N l /min(0.5MPa) For Turbine : 125N l /min(0.5MPa)
Weight	1,350g
Hose Diameter(Turbine, Air Bearing)	$\phi 4.0(\text{I.D.}) \times \phi 6.0(\text{O.D.})$ 2m (Length)
Hose Diameter(Outlet)	$\phi 5.0(\text{I.D.}) \times \phi 8.0(\text{O.D.})$ 1m (Length)
Standard Size Collet Chuck	$\phi 3.0\text{mm}(\phi 3.175\text{mm}(1/8\text{''}))$ for USA market
Usable Max. Diameter of Grindstone	$\phi 8.0\text{mm}$

<Optional>

Collet chuck (CHA-□□)	$\phi 0.5\text{mm}-\phi 4.0\text{mm}$ in 0.1mm increments and $\phi 2.35\text{mm}, 3.175\text{mm}$
Chuck Nut	K-263

Standard Equipment Accessories

- Collet Chuck $\phi 3.0\text{mm}$ or $\phi 3.175\text{mm}$ provided
- Spanner (12 X 14)
- Outlet Air Hose (With Silencer)
- Inlet Air Hose (K-215) 2pcs
- Spanner (10 X 10)
- Operation Manual

3-2 Outside View

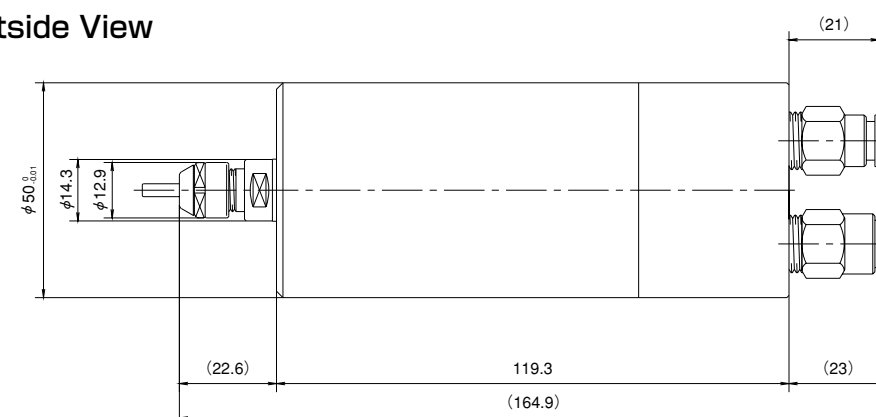

Fig.1

4 Connection of Air Line Kit

Caution in use of Air Line Kit.

- Air bearings require a clean, dry air supply for proper operation. The entry of moisture condensation and debris into air bearings could result in poor performance and malfunction of air bearings.
Connect an air filter and/or air dryer between the compressor and the NAKANISHI air line kit to ensure a clean, dry air supply.
In high humidity areas or during humid seasons, the Air Line Kit may not be able to sufficiently remove moisture from the supply air, and moisture could cause the spindle to malfunction, Install a large capacity air filter or air dryer close to the air line kit.
- Do not supply lubrication. Oil will cause damage to the spindle.
- Please check the integrity of the hose. If the connection is too loose, it can slip out of the connector during high speed rotation.
The usual air pressure for the air piping hose is less than 1.0MPa.
Check that the operating pressure of the compressor is less than 1.0MPa prior to connecting to the air line kit. If this is over 1.0MPa, this will cause the hose to burst.
- Please read "the connection of Air Line Kit" "the Air Line Kit Operation" "Caution in handling Air line kit" in AL-982 Operation Manual, prior to connecting.

Use of Air Line Kit AL-982

Connect Air Supply Hose to Air Turbine Connector ('TURBINE') and Air Bearing Connector ('BEARING') correctly. (Fig2, Fig. 3)

To open

- Check that Lever ④ · ⑦ are closed when Air Hose ① is connected to Air Hose Connector ②, and supply clean, dry air to the air line kit.
- Connect ABS-800 to AL-982 by the inlet hose.
 - Connect Connector for Air Bearing Hose ⑧ to Connector for Air Bearing Hose ⑨ by the Inlet Hose.
 - Connect Connector for Air Turbine Hose ⑤ to Connector for Air Turbine Hose ⑩ by the Inlet Hose.
- Open Lever for Air Bearing ⑦ and supply air to the air bearings. Check that the air pressure is 0.5MPa.
- Check that the spindle rotates lightly, and open Lever for Air Turbine ④ and supply air to the air turbine. The appropriate pressure for Air Turbine is 0.3-0.5MPa.

To stop

- Close Lever for Air Turbine ④ and stop air supply to the air turbine.
- Wait for a few minutes until the spindle stops. Close Lever for Air bearing ⑦ and stop air supply to the air bearings.

CAUTION

- DO NOT CONNECT AIR SUPPLY HOSES IN REVERSE. THIS WILL CAUSE DAMAGE TO THE SPINDLE.
- DO NOT STOP AIR SUPPLY WHILE THE SPINDLE IS ROTATING AT HIGH SPEED OR SUPPLY AIR TO THE AIR BEARINGS AT LOW AIR PRESSURE. THE SPINDLE AND THE AIR BEARINGS COULD BURN AND SEIZE.

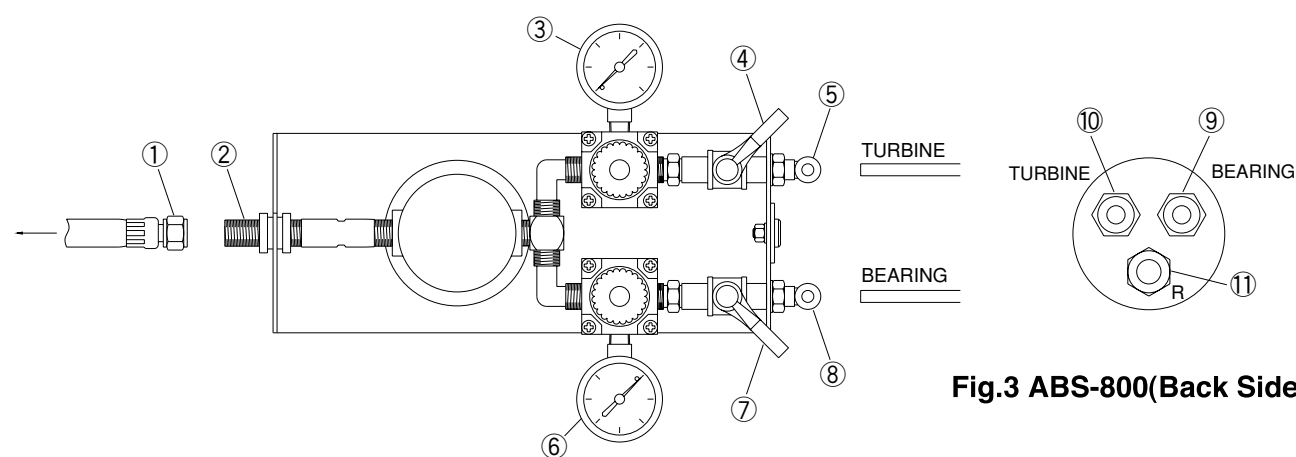

Fig.2 AL-982

Fig.3 ABS-800(Back Side)

- Air Hose
- Air Hose Connector
- Air Pressure Gauge for Air Turbine
- Lever for Air Turbine
- Connector for Air Turbine Hose
- Air Pressure Gauge for Air Bearing
- Lever for Air Bearing
- Connector for Air Bearing Hose
- Connector for Air Turbine Hose (ABS-800)
- Connector for Air Bearing Hose (ABS-800)
- Connector for Exhausted Air Hose (ABS-800)

5 Changing Cutting Tools

- Supply air to Air Bearing.
- Set the provided spanner 12mm on the spindle to be fastened.
- Set the provided spanner 10mm on the chuck nut, and turn it counterclockwise to loosen the chuck.
And pull out the tool.
(The chuck nut is rotation will tighten after one turn, turn it more, and the chuck will open)
- Insert another tool, and turn the chuck clockwise to fasten the tool.

CAUTION

- NEVER CHANGE CUTTING TOOLS OR COLLET WITHOUT SUPPLYING CLEAN, DRY AIR TO THE BEARING SURFACES. THIS WILL CAUSE DAMAGE TO THE SPINDLE, BECAUSE AIR BEARING USE COMPRESSED AIR BLOWN INTO A SMALL GAP BETWEEN THE SPINDLE AND THE BEARING SURFACE.**
- When tightening the chuck nut, insert the tool into the chuck at first. If the chuck without the tool is over tightened, this will cause damage to the chuck & the chuck nut, and the chuck may not be able to be removed.**

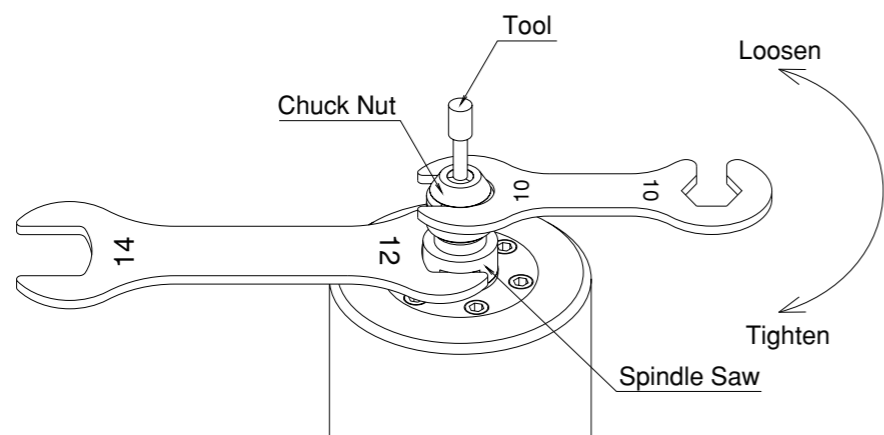

Fig.4

6 Replacing the Collet

- The chuck nut is loosened together with the tool according to "5.Changing Cutting Tools" procedure above. Turn the chuck nut and remove from the spindle shaft, and pull out the chuck nut with the tool from the spindle shaft.
Then pull out the tool from the chuck. (Fig.5)
- Hold the chuck nut in one hand and push the chuck diagonally toward the spanner flat to remove (Fig.6)
- The new chuck can be attached by inserting the new chuck diagonally toward the spanner flat. (Fig.6)

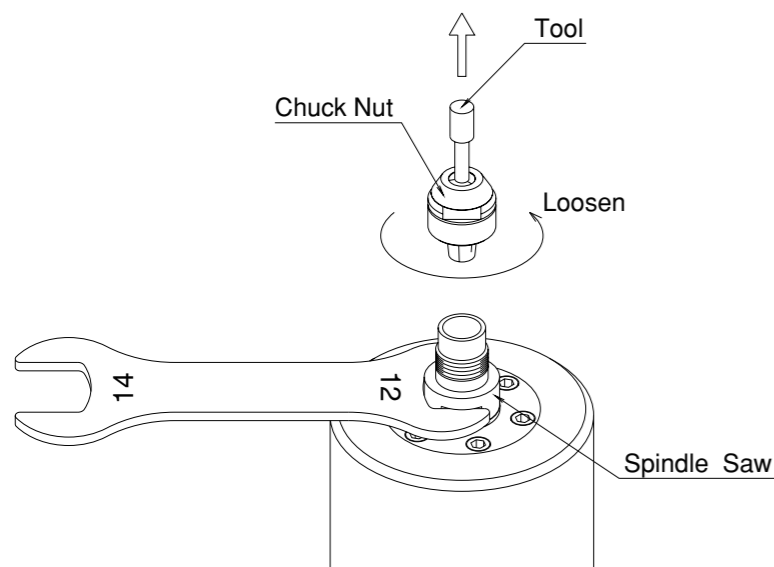

Fig.5

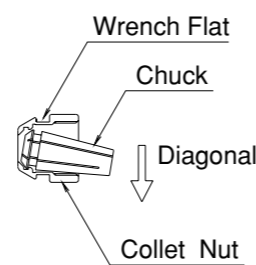

Fig.6

7 Installation of Motor and Spindle

When installing an air bearing spindle, it is not recommended to fix the spindle with a fastening bolt in direct contact with the spindle body as shown in Fig.9.

This can cause deformation of the spindle body and damage internal components.

The installation shown in Fig.7 is the recommended installation method. Therefore, the installation as shown in Fig.7 is the most recommended.

(In case the above is impossible, install as shown in Fig.8)

When mounting the spindle avoid the area where bearings are located. If the spindle is mounted inappropriately, this will cause and damage to the spindle.

(Refer to the clamping area drawing in Fig.10)

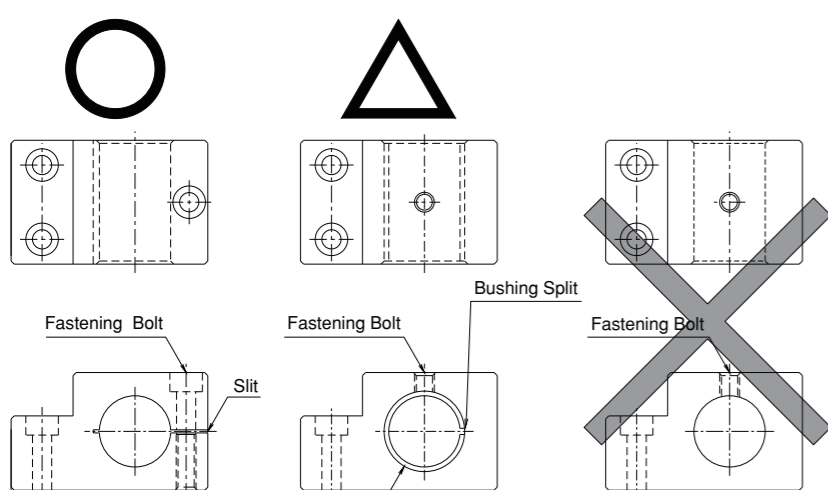

Fig.7

Fig.8

Fig.9

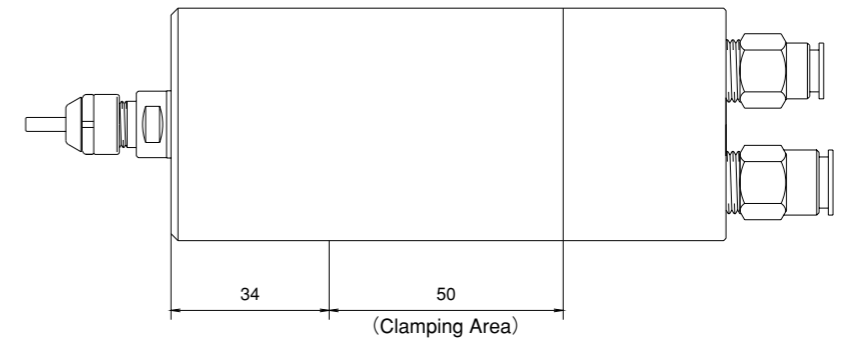

Fig.10

Caution about bushing type Holder

Insert a shim to the holder bore, and tighten the bolt with the regulated torque.
Manufacture the holder with roundness and cylindrical tolerance of less than $5\mu\text{m}$.
Insert a thin shim into the split in the holder to maintain the split gap at $5\mu\text{m}$ (Reference value) and tighten the clamping bolt to the torque specified for that size and type of bolt.
The final responsibility for ensuring a product's suitability for use in a given application is left to the designer of the equipment in which NAKANISHI's spindle is installed. NAKANISHI offers spindles with a wide variety of capabilities and specifications. Please carefully check the product's specifications against the requirements of your application and verify suitability and safety prior to initial use.

8 Cutting Tool Cautions

- The proper surface speed for vitrified grindstones is 600-1,800m/min.

CAUTIONS

Do not exceed a surface speed of 2,000m/min for grinding.

$$\text{Surface Speed (m/min)} = \frac{3.14 \times \text{Diameter (mm)} \times \text{rotation Speed (min}^{-1}\text{)}}{1,000}$$

- Do not exceed 13mm overhang for mounted grindstones. In case overhang must exceed 13mm reduce the motor speed in accordance with Fig.11.
- Do not use tools with bent or broken shanks, cracks or excessive runout.
- Dress the grindstone prior to use.
- For grinding the maximum depth of cut should not exceed 0.01mm radially or axially. Reciprocate the tool several times after each in feed step.
- Always operate tools within the tool manufacturer's recommended speed limits. Use of a tool outside of the manufacturer's recommended speed limits could cause damage to the spindle and injury to the operator.
- Keep the tool shank and collet clean. If contaminants are left in the collet they can cause excessive runout and damage the tool and spindle.
- Do not drop or hit spindle.

Table 1. Overhang and Speed

Overhang (mm)	Speed (min^{-1})
20	$N \times 0.5$
25	$N \times 0.3$
50	$N \times 0.1$

N:Max.Operating Speed at 13mm Overhang

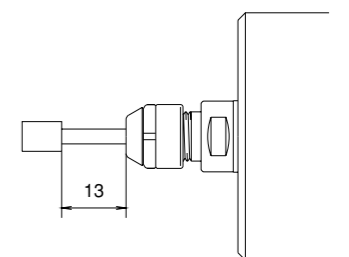

Fig.11

9 Troubleshooting

When the trouble is found, please check the following prior to consulting your dealer

Trouble	Cause	Inspect/Corrective Action
Tool Slippage	Contaminants inside the chuck or the spindle.	Clean the inside of the chuck and the spindle.
	Collet is not properly positioned.	Set the chuck properly.
	Set the air pressure for Air Bearing too low.	Set the air pressure for Air Bearing correctly.
	Cutting tool is bent	Replace cutting tool.
Noise or vibration during rotation	Set the air pressure for Air Bearing too low.	Set the air pressure for Air Bearing correctly.
	Bent tool.	Change the tool.
Poor Rotation	Ground Particles or atomized oil stuck in the air of Air Bearing.	Supply clean, dry air after repair.
	Overload will cause poor rotation. Or the friction of Spindle and Bearing.	Lower Load.

※Specifications may be changed without notice.

NAKANISHI INC.
www.nakanishi-inc.com

700 Shimohinata Kanuma-shi
Tochigi 322-8666,
Japan

NSK Europe GmbH EC REP
www.nsk-europe.de

Elly-Beinhorn-Strasse 8
65760 Eschborn,
Germany

NSK America Corp
www.nskamericacorp.com

1800 Global Parkway
Hoffman Estates, IL 60192,
USA