

## Ultra-precision High-Speed Air Turbine Spindle

# HTS1501S

## OPERATION MANUAL

OM-K0389E Rev.B

Thank you for purchasing the Ultra-Precision, High-Speed Air Turbine, HTS1501S. HTS1501S was designed for use on machining centers without rotating the machine's main spindle. HTS1501S uses an Ultra-precision collet system and is ideal for use with small diameter end mills in mold making applications. The Air Line Kit(with Lubricator) is used to drive HTS1501S. Please read this Operation Manual carefully prior to use.

### 1 Cautions for handling and operation

- Read these cautions carefully and only use in the manner intended.
- Safety instructions are intended to avoid potential hazards that could result in personal injury or damage to the device. Safety instructions are classified as follows in accordance with the seriousness of the risk.

Class	Degree of Risk
<b>WARNING</b>	A hazard that could result in bodily injury or damage to the device if the safety instructions are not followed.
<b>CAUTION</b>	A hazard that could result in light or moderate bodily injury or damage to the device if the safety instructions are not followed.

#### WARNING

- HTS1501S is not a hand tool. It is designed to be used on machines.
- Never rotate the main spindle of the machining center.
- Never touch the motor, spindle or cutting tools when the spindle is rotating.
- Always wear safety glasses. Everyday eyeglasses only have impact resistant lenses, they are not safety glasses. Also use a dust or face mask whenever the motor is running.
- Do not apply excessive force(deep per pass cuts, high feed rates) . This may cause tool slippage or spindle damage.
- Do not use unbalanced or low precision tools.
- Use less than  $\phi 1.0\text{mm}$  square end mill, less than  $R0.5\text{mm}$  ball end mill, or less than  $\phi 4.0\text{mm}$  grindstone for tools to avoid danger.

#### CAUTION

- Do not drop or hit HTS1501S, the shock can damage internal components.
- Check that the collet has been securely tightened prior to each use.
- Always clean the chuck. If ground particles or metal chips stick to the inside of spindle or the chuck, this will cause damage to the chuck or spindle and loss of precision.
- Do not over tighten the chuck. This will cause spindle damage.
- An Air Line Kit is necessary for use with HTS1501S. The motor speed will be decreased and the lifetime will be shortened without the use of an Air Line Kit.
- Always drain water from the air filter(Air Line Kit). Water or ground particles will cause rust or damage to the internal parts of the turbine.
- Select suitable products or tools for the application. Do not exceed the capabilities of the spindles or cutting tools.
- Stop working immediately when abnormal rotations or unusual vibrations occur.
- If the spindle has not been used for a long period of time, in excess of one month , start at a low air pressure and run the spindle as slowly as possible. Over a period of 15-20 minutes, raise the air pressure and spindle speed incrementally until you reach the maximum allowable speed. Check for abnormal noises, vibration or heat.
- Check if tools or chucks are damaged before working.

### 2 Features

- The shank is taper type : BT30 · BT40 · BT50 · HSK E25 · HSK E32 · HSK E40 · HSK E50 · HSK A63 · HSK F63 · straight (M2040)
- The spindle's housing is made of precision-ground stainless steel (SUS-416)
- A wide selection of collet chucks are available depending on application requirements.
- Air driven system generates extremely little heat, even after many hours of continuous use.
- Designed for use with the attachment of less than  $\phi 1.0\text{mm}$  square end mill or less than  $R0.5\text{mm}$  Ball end mill.

### 3 Specifications & dimensions

#### 3-1 Specifications

Motor speed	150,000min <sup>-1</sup> (0.5MPa)
Appropriate Air Pressure	0.5MPa(5.0kgf/cm <sup>2</sup> )
Spindle Accuracy	Within 1 $\mu\text{m}$
Taper type	BT30 · BT40 · BT50 · HSK E25 · HSK E32 · HSK E40 · HSK E50 · HSK A63 · HSK F63 · Straight Type (M2040)
Air Consumption	90N $\ell$ /min
Weight	1,030g(HTS1501S-BT30) 1,700g(HTS1501S-BT40)
Standard Collet Chuck(CHA-4.0)	$\phi 4.0\text{mm}$
Air Inlet Hose	$\phi 6.0\text{mm(OD)} \times 4\text{m}$
Tools Sizes	Less than $\phi 1.0\text{mm}$ Square End Mill Less than $R0.5\text{mm}$ Ball End Mill Less than $\phi 4.0\text{mm}$ Grindstone

<Optional>

Collet chuck (CHA-□□)	$\phi 0.5\text{mm}-\phi 4.0\text{mm}$ in every increments, $\phi 2.35\text{mm}$ , $\phi 3.175\text{mm}$
Chuck nut	CHN-A

#### Standard Accessories

- Collet Chuck  $\phi 4.0\text{mm}$  (provided) 1pc.
- Spanner(8 $\times$ 5) 1pc.
- Air hose with filter joint 4m
- Chuck Nut (provided) 1pc.
- Spanner(11 $\times$ 9) 1pc.
- Operation manual

#### 3-2 Dimensions

- ① HTS1501S-BT30    ② HTS1501S-BT40    ③ HTS1501S-BT50    ④ HTS1501S-M2040

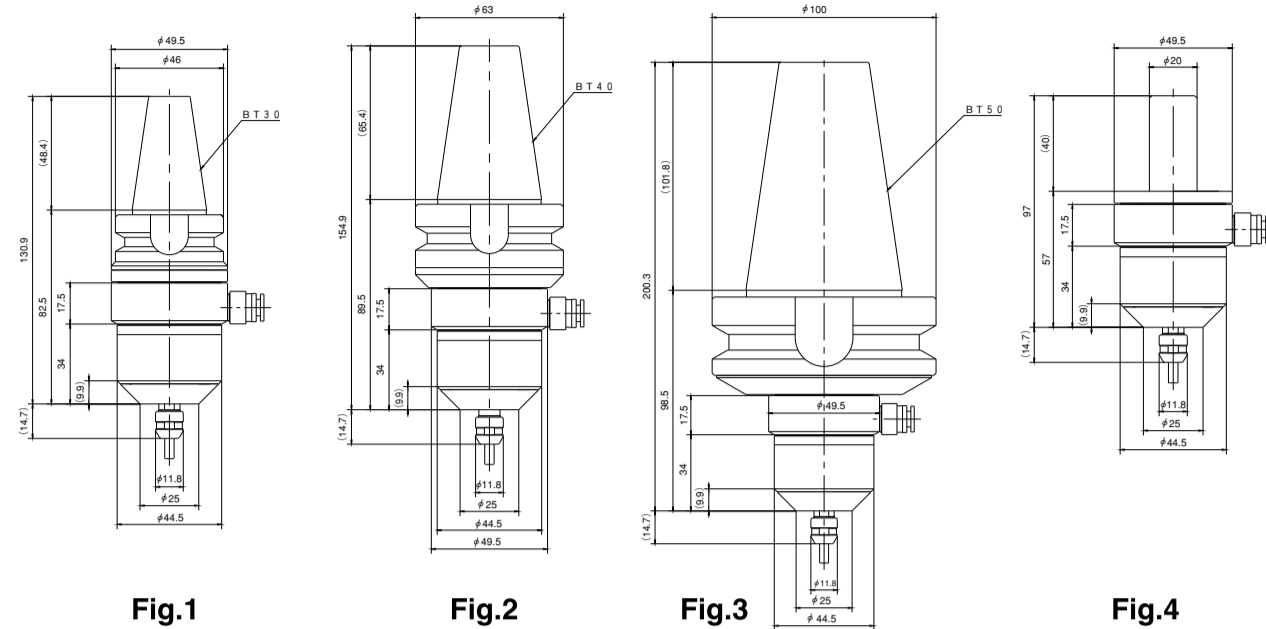

Fig.1

Fig.2

Fig.3

Fig.4

- ⑤ HTS1501S-HSK E25    ⑥ HTS1501S-HSK E32    ⑦ HTS1501S-HSK E40    ⑧ HTS1501S-HSK E50

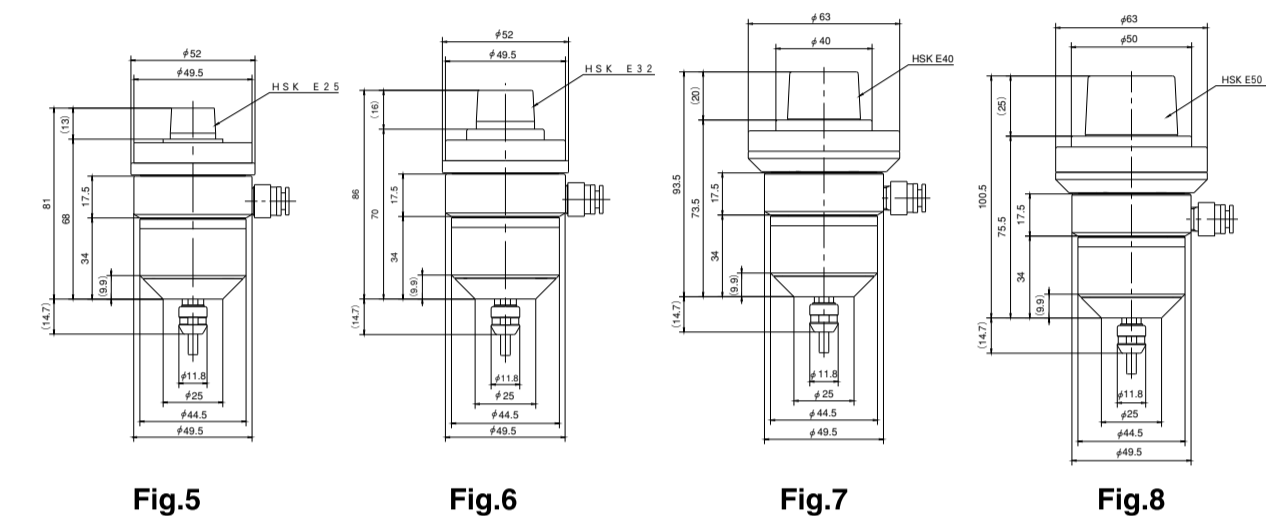

Fig.5

Fig.6

Fig.7

Fig.8

- ⑨ HTS1501S-HSK A63    ⑩ HTS1501S-HSK F63

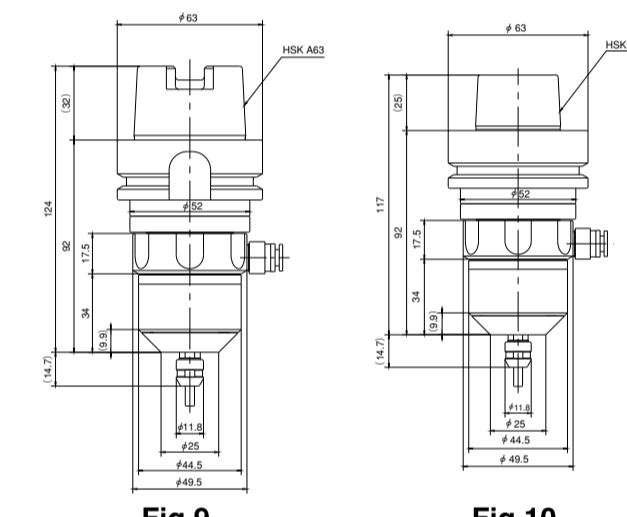

Fig.9

Fig.10

### 4 Replacement of tools

Replace the tools according to the following procedure.

- Place the provided 8mm spanner on the spindle shaft to fasten.
- Place the provided 11mm spanner on the chuck nut, and turn it counterclockwise to loosen the chuck. And pull out the tool. (The chuck nut will loosen but the collet will not release the tool after one turn, turn it more, and the chuck will open.)
- Shorten the length of max. tool mounting as possible when inserting another tool.
- Turn the chuck clockwise to fasten the tool.

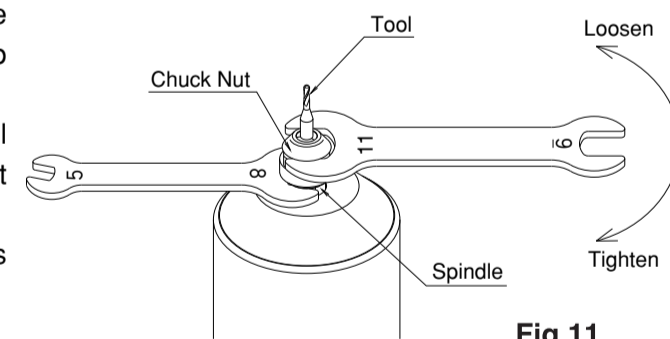

Fig.11

#### CAUTION

Never install a collet into the spindle quill without first assembling it in the chuck nut. Do not tighten the collet without mounting a cutting tool or test bar as this will result in a damage to the collet, spindle and collet nut and make it impossible to remove the collet.

### 5 Replacement of the chuck

Replace the chuck according to the following procedure.

- The chuck nut is loosened together with the tool according to the "4.Replacement of Tools" procedure above. And unscrew the chuck nut and remove the collet and chuck nut. Then remove the tool from the chuck. (Fig.12)
- Hold the chuck nut in one hand and push the collet diagonally toward the spanner flat to remove the collet from the chuck nut (Fig.13)
- The new chuck can be attached by inserting the new chuck diagonally toward the spanner flat(Fig.13) and pressing straight down.

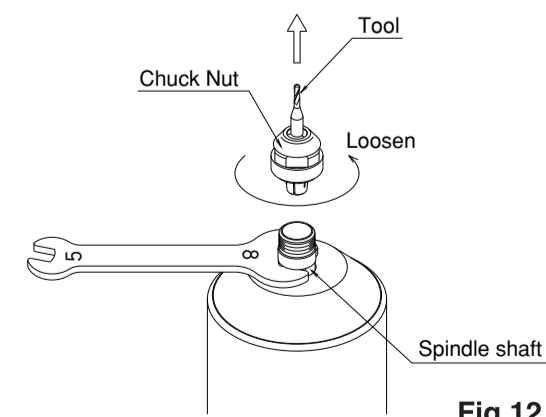

Fig.12

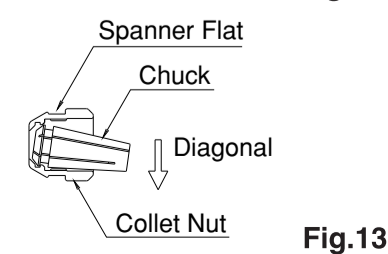

Fig.13

## 6 Attachment of the main spindle on machining center

### ⚠ WARNING

When HTS1501S is used, never rotate the main spindle on the machining center. Rotating the main spindle will damage HTS1501S and could cause personal injury.

- ① Attach HTS1501S into the quill of the machining center.
  - ② Secure the air hose to a suitable place on the machining center and check that you have allowed enough slack for the quill's full range of motion.
- ※ If the main spindle is rotated by mistake, check the air hose and machining center for damage. And use it only after test-running.

## 7 Connection & Instruction of Air Line Kit (AL-0304)

- ① Connect the Filter Joint of the Air Intake Hose of HTS1501S to the Hose Connector on the Air Line Kit.
- ② Attach the other end of the Air Intake Hose to the easy connection joint on the HTS1501S.
- ③ Fill oil reservoir through the Oil Filler Cap with recommended NAKANISHI oil (liquid paraffin ISO VG15) to upper limit on the Reservoir. Disconnect from air supply prior to opening Oil Filler Cap. Do not over or under fill.
- ④ Attach the hose for air piping to the connector on the Airline kit.
- ⑤ Attach the opposite side of the hose for air piping to the air compressor.
- ⑥ Supply air from the air compressor and turn regulator knob clockwise (clockwise=high) to set air pressure between 0.5MPa.
- ⑦ Run the motor at the proper pressure. Close the Oil Drip Rate Adjusting Screw by turning clockwise and then turn Oil Drip Rate Adjusting Screw counterclockwise to adjust drip rate to 30-40 drops/min. (If you're not using an NAKANISHI lubricator, adjust between 1-3 drops/min.)
- ⑧ After setting the proper drop rate you are all ready to use the air motor /spindle.

### ⚠ CAUTION

NAKANISHI's lubricators deliver approximately 3% of the visible drip rate into the air line, but air flow and oil viscosity could affect this rate. Please adjust the oil drip rate so that a full oil bowl depletes in 40-50 hours.

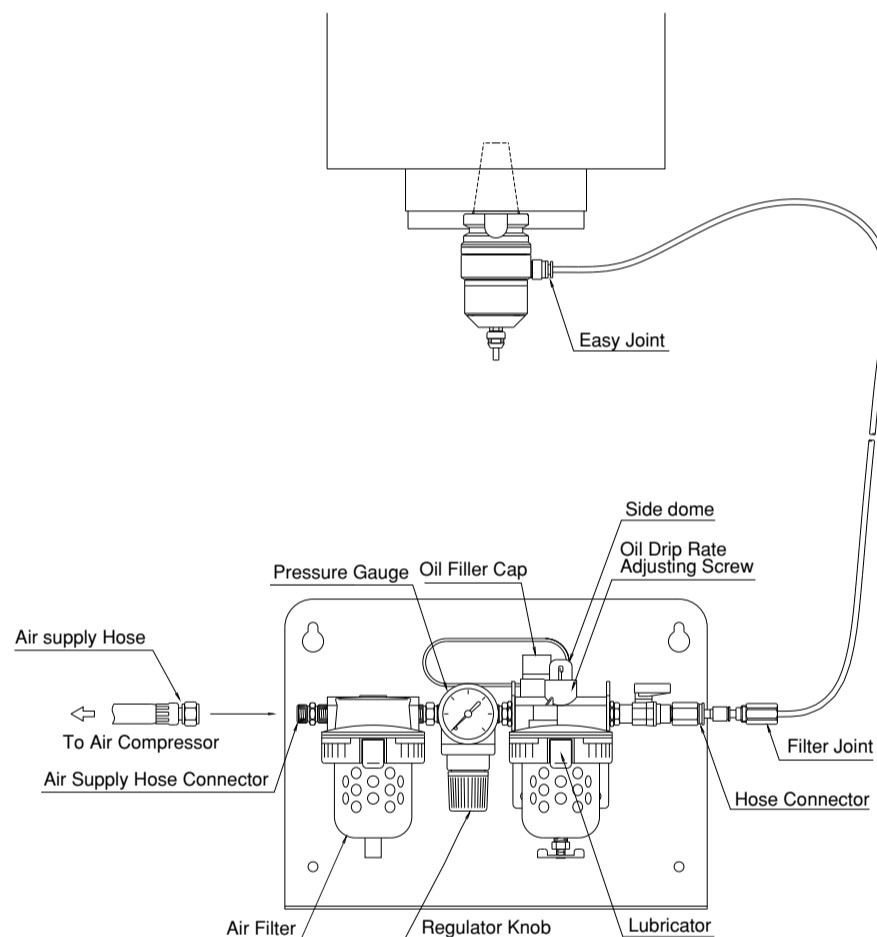

Fig.14

### ⚠ Cautions for Air Line Kits

- ① HTS1501S require a clean, dry air supply to the air line kit for proper operation. Please connect an air filter and/or dryer between the compressor and NAKANISHI's air line kit to ensure a clean, dry air supply. Mount the air line kit as close as possible to the spindle to ensure a constant oil supply. In high humidity areas please use a large capacity filter and/or dryer to ensure years of trouble free operation.
- ② Check that all hose connections are secure and strong to avoid accidental disconnection during operation. Do not exceed 1.0MPa for incoming air pressure to the air line kit. Incoming air pressure from the compressor in excess of 1.0MPa may cause the air hose to burst.
- ③ About connection, operation and cautions of Air Line Kit, refer to "Air Line Kit Operation Manual".

## 8 Air Line Kit Operation

### ① Oil Volume (Fig.15)

Check the oil volume at least once a week. If the oil level is low, fill to the upper limit. If the oil level is above the upper limit, remove the excess oil. Take care not to over or under fill the oil reservoir as this can cause the oil delivery rate to vary.

### ⚠ CAUTION

When oil is added or drained, be sure to disconnect the incoming air supply from the Compressor, prior to opening the Oil Filter Cap.

### ② Moisture in the Air Filter (Fig.16)

Drain moisture from the Air Filter by pushing the Drain Valve sideways.

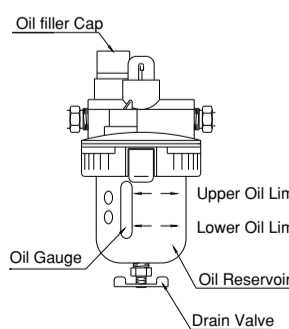

Fig.15

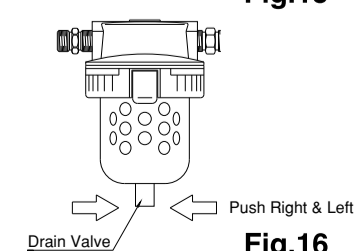

Fig.16

### ③ Adjusting the Oil Drip Rate (Fig.17)

Run HTS1501S at the specified air pressure and adjust the oil drip rate to the recommended rate by turning the Oil Drip Rate Adjusting Screw. (About 30 to 40 drips/min) Turn the screw counterclockwise to increase the rate and clockwise to decrease. When using non-NAKANISHI lubricator, adjust the oil drip rate to about 1-3 drips/min.

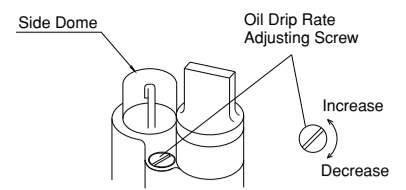

Fig.17

### ④ Remove Oil and Moisture Regularly (Fig.18)

Remove and replace the oil in the Reservoir once a month, to ensure a pure oil source for the motor. Moisture may collect and mix with the oil in the Reservoir and damage the motor. Open the Drain Valve at the bottom of the reservoir by turning it counterclockwise.

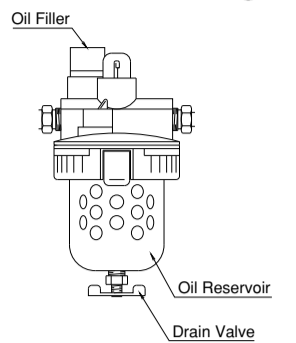

Fig.18

### ⑤ Oil

Liquid paraffin ISO VG15 is recommended.

## 9 Cutting Tool Cautions

- ① The proper surface speed for vitrified grindstones is 600-1,800m/min.

### ⚠ CAUTIONS

Do not exceed a surface speed of 2,000m/min for grinding.

$$\text{Surface Speed (m/min)} = \frac{3.14 \times \text{Diameter (mm)} \times \text{rotation Speed (min}^{-1}\text{)}}{1,000}$$

- ② Do not exceed 13mm overhang for mounted grindstones. In case overhang must exceed 13mm reduce the motor speed in accordance with Fig.19.
- ③ Do not use tools with bent or broken shanks, cracks or excessive runout.
- ④ Dress the grindstone prior to use.
- ⑤ For grinding the maximum depth of cut should not exceed 0.01mm radially or axially. Reciprocate the tool several times after each in feed step.
- ⑥ Always operate tools within the tool manufacturer's recommended speed limits. Use of a tool outside of the manufacturer's recommended speed limits could cause damage to the spindle and injury to the operator.
- ⑦ Keep the tool shank and collet clean. If contaminants are left in the collet they can cause excessive runout and damage the tool and spindle.
- ⑧ Do not drop or hit spindle.

Table 1 .Overhang and Speed

Overhang (mm)	Speed (min <sup>-1</sup> )
20	N × 0.5
25	N × 0.3
50	N × 0.1

N:Max.Operating Speed at 13mm Overhang

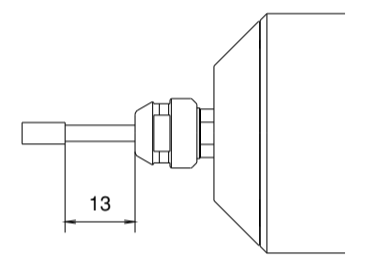

Fig.19

## 10 Use of Coolant

HTS1501 is designed to prevent coolant from entering the motor/spindle by using the air used for driving the turbine as an air purge. Never spray coolant directly on the HTS1501S main body, because coolant may enter the motor/spindle. Coolant or foreign particle contamination of the spindle's internal components will dramatically shorten bearing life.

## 11 Troubleshooting

When the trouble is found, please check the following prior to consulting your dealer.

Trouble	Cause	Inspect/Corrective Action
Low Rotation Speed	Partial disconnection of hose or leaking connection.	Check all joints and re-tighten seal connections.
	Broken Hose	Replace the hose.
	Low air flow or pressure	Check the air circuit.
	No or low oil supply	Check the oil volume in the oil reservoir and increase the drip rate. When using NAKANISHI's lubricator, adjust to 30-40 drops/min, 1-3 drops/min for other lubricators that supply oil directly into the air hose.
	Inclined or vibrating lubricator	If the lubricator is inclined or subject to vibration, a large volume of oil will flow and the spindle will rotate irregularly.
	Excessive oil in oil reservoir.	A large volume of oil will flow and the spindle will rotate irregularly. Drain oil to the appropriate volume by loosening the valve.
	Excessive oil drip rate	Decrease drip rate to stabilize motor speed.
No Rotation	Moisture in the oil reservoir.	Drain moisture from the lubricator and replace oil.
	Moisture in the air filter.	Drain moisture in the air filter.
	No air flow	Check the regulator and set at the appropriate air pressure. Check all hose connections. Check air compressor power supply and air outlet. Check hoses for leaks, bends or disconnections.
Excessive Runout	Damaged motor bearings	Send to NAKANISHI for Repair
	Contaminants inside the chuck or the spindle.	Clean the inside of the chuck and the spindle.
	Collet Nut is not properly positioned	Set the chuck the chuck nut properly
	Cutting tool is bent	Replace cutting tool.
Noise or vibration during rotation	Ball bearing is worn out	Send to NAKANISHI for Repair
	Use the bent tool	Change the tool.
	Ground Particles stuck in the collet chuck or spindle.	Send to NAKANISHI for Repair
	Ball bearing is worn out.	