

Motor Spindle

BMS-4020 · BMS-4020RA

BMS-4040 · BMS-4040RA

OPERATION MANUAL

Thank you for purchasing motor spindle BMS - 4020 · BMS - 4020RA · BMS - 4040 · BMS - 4040RA. This motor spindle designed for grinding, drilling and milling, etc..
The E4000 <CONTROLLER>, and <Air Line Kit> are required to drive this motor spindle.
Read this and a above products Operation Manuals carefully before use.

1. CAUTIONS FOR HANDLING AND OPERATION

- Read these warnings and cautions carefully and only use in the manner intended.
- These warnings and cautions are intended to avoid potential hazards that could result in personal injury or damage to the device. These are classified as follows in accordance with the seriousness of the risk.

Class	Degree of Risk
WARNING	A safety hazard could result in bodily injury or damage to the device if the safety instructions are not properly followed.
CAUTION	A hazard that could result in light or moderate bodily injury or damage to the device if the safety instructions are not followed.

WARNING

- This motor spindle is not a hand tool. It is designed to be used on CNC machines or special purpose machines.
- Do not touch the cutting tool while it is running. It is very dangerous.
- Wear safety glasses, dust mask and use a protective cover around the motor spindle whenever the motor spindle is rotating.
- Never connect, disconnect or touch the Connector and Motor Cord Plug with wet hands. This may cause an electric shock.
- Never operate or handle the motor spindle until you have thoroughly read the owner's manual and safe operation has been confirmed.
 - To prevent injuries / damages, check the motor spindle and cutting tool for proper installation, before operating the motor spindle.
 - Before disconnecting the motor spindle, always turn the control power off and turn the compressed air supply to the CONTROLLER off. Then it is safe to remove the motor spindle.
- When installing a tool, tighten the collet correctly and check again the collet and collet nut before use. Do not over-tighten the collet. This may cause damage to the spindle.
- Do not use bent, broken, chipped, out of round or sub-standard tools as they may cause shatter or explode. Tool with fractures or a bent shank will cause injury to the operator. When using a new tool, rotate it in a low speed and increase speed gradually for safety.
- Do not exceed the maximum recommended allowable tool speed. For your safety, use speeds below the maximum allowable speed.
- Do not apply excessive force. This may cause injury to the operator by slippage or damage of the tool, or loss of concentricity and precision of the motor spindle.

CAUTION

- Do not drop or hit this motor spindle, as shock can damage to the internal components.
- Be sure to clean the collet and collet nut, the inside of the spindle before replacing the tool. If ground particles or metal chips stick to the inside of spindle or the collet, damage to the collet or spindle can occur due to the loss of precision.
- When cleaning a motor spindle, stop the motor spindle and remove debris with a soft brush or a cloth. Do not blow air into the Dust Proof Cover Area (refer to section 3 - 3 " Outside view ") with compressed air as foreign particles or cutting debris may get into the ball bearing.
- Always clean the tool shank before installing the tool in the spindle.
- When sizing the correct collet size to the tool shank diameter, a tolerance of +0 ~ -0.01mm is strongly recommended. A tool shank within the +0 ~ -0.1mm range is mountable, however, this may cause poor concentricity and or insufficient tool shank gripping force.
- Select suitable products or tools for all applications. Do not exceed the capabilities of the motor spindle or tools.
- Carefully direct coolant spray to the tool. Do not spray directly on the motor spindle body.
- Stop working immediately when abnormal rotation or unusual vibration are observed. Afterwards, please check the content of section 10 " TROUBLESHOOTING ".
- Always check if the tool, collet or collet nut are damaged before and after operating.
- If the collet or collet nut show signs of wear or damage, replace them before a malfunction or additional damage occurs.
- After installation, repair, initial operation, or long periods of non operation, please refer to section 8. " BREAK-IN PROCEDURE " detailed in Table 1. When checking the motor spindle, no vibration or unusual sound should be observed during rotation.
- Do not disassemble, modify or attempt to repair this motor spindle. Additional damage will occur to the internal components. Service must be performed by NSK NAKANISHI or an authorized service center.
- When using this motor spindle for mass production, please purchase the another motor spindle as a spare in case of an emergency.

2. FEATURES

- The motor spindle housing is made from precision ground, hardened, stainless steel (SUS) with an outside diameter of $\phi 40$ mm.
- Excellent durability and high reliability are obtained by using a high-speed motor spindle, which eliminates the need for brush replacement and frequent maintenance.
- A quick disconnect cord is available for easy motor spindle removal.

3. SPECIFICATIONS AND DIMENSIONS

3 - 1 Specifications

Model	BMS - 4020	BMS - 4020RA	BMS - 4040	BMS - 4040RA
Maximum Motor Rotation Speed	20,000min ⁻¹		40,000min ⁻¹	
Spindle Accuracy	Within 1 μ m			
Max. Output	1,200W			
IP Code	Motor Spindle : IP57, Motor Cord : IPX7			
Weight	1.5kg	2.0kg	1.5kg	2.0kg
Noise Level	Less than 70dB			

	Temperature	Humidity	Atmospheric Pressure
Operation Environment	0 - 40°C	MAX.75% (No condensation)	800 - 1,060hPa
Transportation and Storage Environment	-10 - 50°C	10 - 85%	500 - 1,060hPa

Standard Accessories

- Collet Nut (CHN - 16) · · 1pc.*
- Wrench (17 x 22) · · 2pcs.
- Operation Manual · · 1set

*The collet nut is attached to the spindle.

<Option>

Collet (CH16- □ □)	$\phi 3.0$ mm, $\phi 3.175$ mm, $\phi 4.0$ mm, $\phi 6.0$ mm, $\phi 6.35$ mm, $\phi 8.0$ mm, $\phi 10.0$ mm
*Note 1	
Collet Nut	CHN - 16

Motor Cord	EMCD - 4000 - □ M (Power Line)	Motor Cord Length : 2m, 4m, 6m and 8m. (The Air Hose ($\phi 6$ mm) of the same length is attached.)
*Note 2	EMCD - 4000S - □ M (Signal Line)	Motor Cord Length : 2m, 4m, 6m and 8m. (The Air Hose ($\phi 6$ mm) of the same length is attached.)

*Note 1 : Collet is sold separately. Please select the suitable collet size for your application.

*Note 2 : Motor Cord is sold separately. Please select the suitable motor coed length for your application.

CAUTION

These Motor Cord <EMCD - 4000 - 8M and EMCD - 4000S - 8M> are never use for Angle Type Motor Spindle <BMS - 4020RA and BMS - 4040RA>.

3 - 2 Compatibility

This motor spindle is compatible with the following overseas safety standards.

- Safety Standards in North America (UL, CSA)
- UL1004 (+CSA 100-04)

3 - 3 Outside View

① BMS - 4020 · BMS - 4040

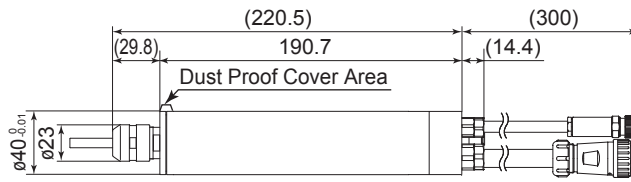

Fig. 1

② BMS - 4020RA · BMS - 4040RA

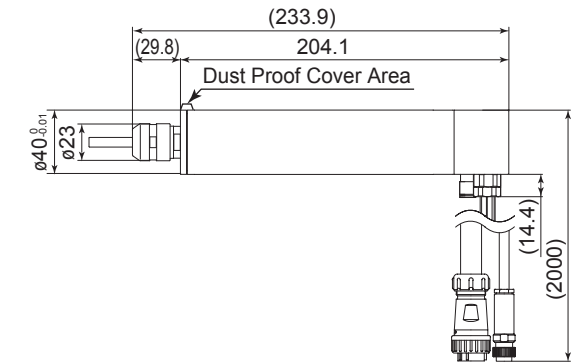

Fig. 2

3 - 4 TORQUE CHARACTERISTICS

① BMS - 4020 · BMS - 4020RA

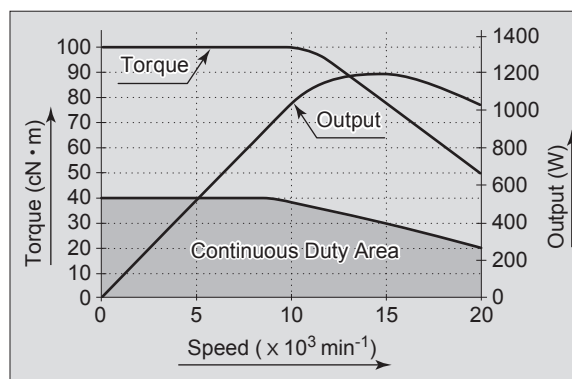

Fig. 3

② BMS - 4040 · BMS - 4040RA

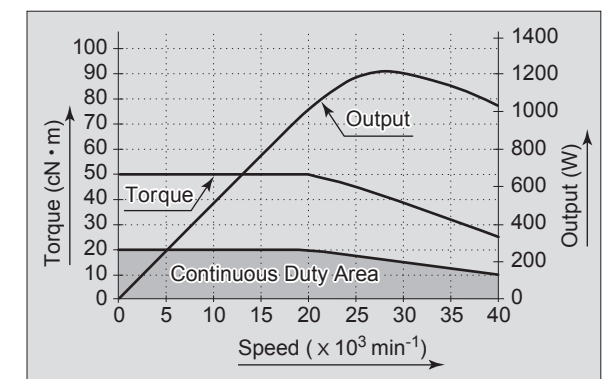

Fig. 4

3 - 5 Air Supply

Set the air pressure to 0.35MPa for continuous use, although the motor spindle can be operated at the air pressure within 0.2 - 0.35MPa.

4. CHANGING THE TOOL

CAUTION

Do not tighten the collet without inserting a tool or dummy bur, as this will damage the collet, spindle or collet nut, causing difficulty removing the collet.

- Set the provided 17mm wrench on the spindle.
- Place the provided 22mm wrench on the collet nut and turn it counterclockwise to loosen the collet and remove the tool. (The first turn will loosen the collet nut, but the tool will not release and turning will become stiff. Keep turning through the stiffness and the collet will open.)
- Clean the collet and collet nut, then insert the new tool and tighten the collet nut by turning clockwise. Do not over tighten.

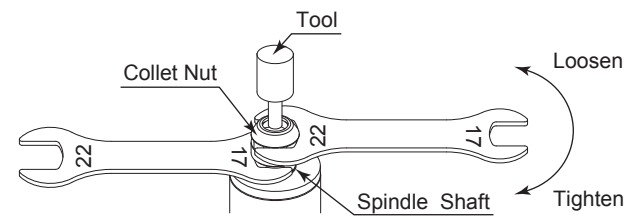

Fig. 5

5. REPLACING THE COLLET

CAUTION

When installing the collet into the collet nut, be sure to fully engage the latch inside the collet nut to the groove on the collets outer diameter area. In addition, remember that if the collet is attached without being engaged with the latch of the collet nut, the collet cannot be removed and this may cause damage to the collet or the spindle.

- Remove the tool according to the section 4. "CHANGING THE TOOL" procedure above and remove collet nut assembly. (Fig. 6)
- The collet and collet nut are secured by a groove in the collet and a flange in the collet nut. To remove the collet hold the collet nut in one hand and push diagonally down on the collet. The collet should be released. (Fig. 7).
- To install the collet, hold the collet at a slight angle, and insert it into the collet nut (Fig. 8). Press the collet in the collet nut by positioning the collet in the collet nut and pressing down on flat surface (Fig. 7). Be sure to fully engage the latch inside the collet nut into the groove on the collet's outer circumference area (Fig. 9).

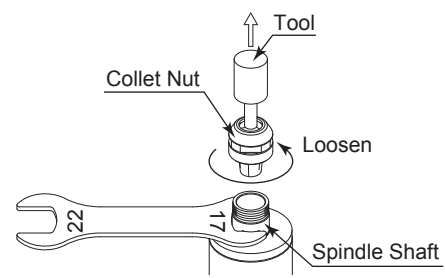

Fig. 6

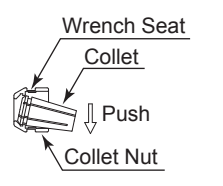

Fig. 7

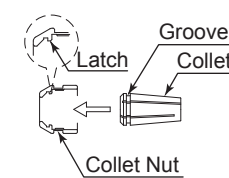

Fig. 8

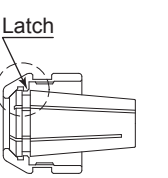

Fig. 9

6. CONNECTION OF MOTOR CORD

CAUTION

- Before connecting to the Motor Cord Plug, make sure the Main Power Switch in the CONTROLLER is turned OFF. If the Main Power Switch on the CONTROLLER is ON while connecting the Motor Cord Plug, damage may cause to the CONTROLLER.
- Install the protective cover (Protective Cover etc.) to prevent damage or contamination to the Motor Cord Plug when not in use.

- Remove the Protective Cover from the Motor Cord (Power Line, Signal Line).

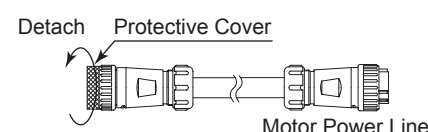

Fig. 10

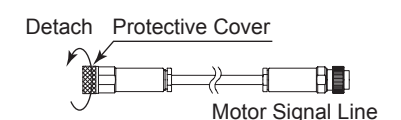

Fig. 11

- ② Ensure the Alignment Pin (Motor Spindle Side) and Alignment Hole (Motor Cord Side) are located (12 o'clock) upward. Carefully insert the alignment pin into the alignment hole and push straight into the Connector of the Motor Cord.



Fig. 12

- ③ Tighten the Connector Nut with clockwise.

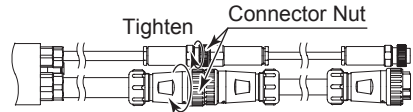

Fig. 13

- ④ Insert the φ6mm air hose (Motor Cord Accessories) to the air joint of air hose of the Motor Spindle Side.

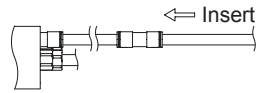

Fig. 14

7. INSTALLATION OF THE MOTOR SPINDLE

WARNING

When installing a motor spindle to a fixed base, make sure the fixed base is grounded in order to avoid the risk of an electric shock.

CAUTION

- When installing a motor spindle, do not hit, drop or cause shock to the motor spindle. This may cause damage to internal components and result in malfunctions.
- When mounting the motor spindle, be sure to mounting within clamping area etched on the motor spindle. If the motor spindle is installed incorrectly, this will cause and damage to the motor spindle.
- Cautions when tightening the securing bolt of the Split Type Holder. Do not over tighten the bolt. This may cause damage to motor spindle's precision. Tighten the bolt until the motor spindle body can not be turned by hand within the fixture. Extreme tightening is not necessary or recommended. Apply working force and check that the motor spindle is tight before using.

- ① When mounting a motor spindle, refer to the Clamping Area etched on the spindle (Fig. 15).

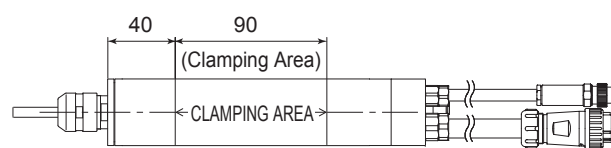

Fig. 15

*When installing a motor spindle, use a "Grip Ring GR - 40 (sold separately)" recommended. If the Grip Ring GR - 40 (sold separately) cannot be used due to the restriction of dimension and space, install as shown in ② below.

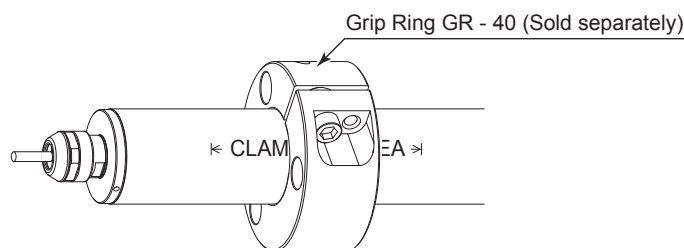

Fig. 16

- ② When installing a motor spindle to the holder, recommended installation method is shown Fig. 17 Refer to "③ How to fabricate the Split Type Holder". If this is not possible, install as shown in Fig. 18.

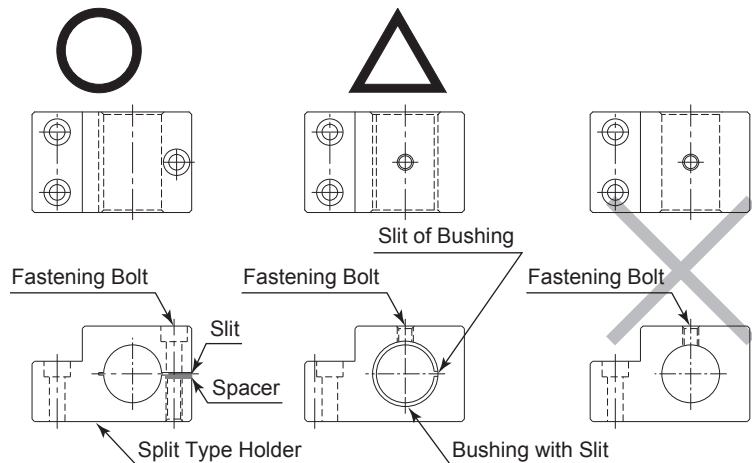

Fig. 17

Fig. 18

Fig. 19

CAUTION

Do not allow set screws to come directly in contact with the motor spindle body as shown in Fig. 19, as this will result in damage to the motor spindle housing and internal components. When installing, never clamp directly over the bearings, as this will result in bearing damage. (Refer to Fig. 20)

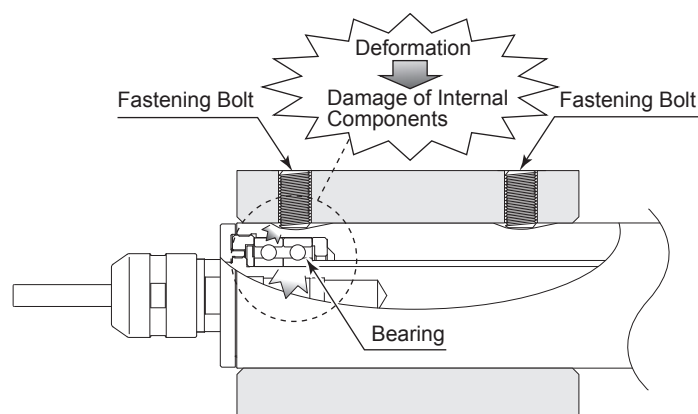

Fig. 20

- ③ How to fabricate the Split Type Holder

- (1) Roughly process (carve) the inside diameter of the Split Type Holder.
- (2) Cut a slit. (Ex. Slit 2mm)
- (3) Twist the Screw for Removal and Broaden the Slit Area.
- (4) Insert spacer (ex t = 2mm) into the Slit Area.
- (5) Loosen the Screw for Removal, and tighten the fastening bolt with the specified torque.
- (6) Finish the Split Type Holder so that the inside diameter of the Split Type Holder is φ40 with its tolerans range from -0.01mm to -0.015mm, and its roundness and cylindricity of less than 5 μm.
- (7) When inserting the motor spindle loosen the Fastening Bolt and twist the Screw for Removal, and broaden the Slit Area.

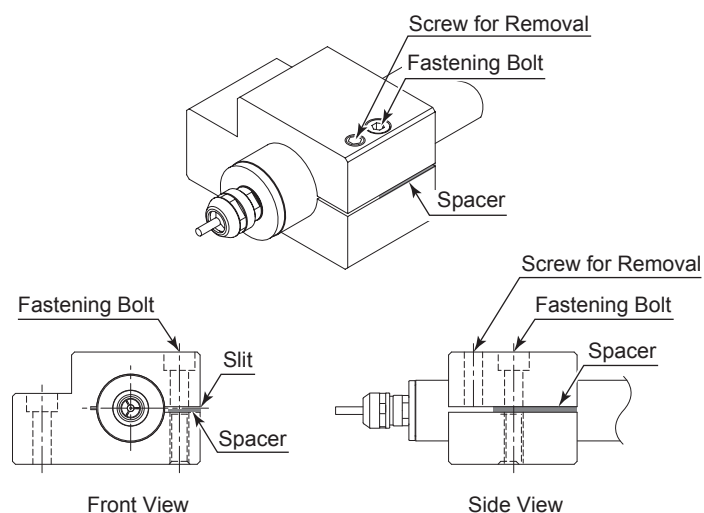

Fig. 21

CAUTION

- How to confirm the tightening standard of the holder by the clamp meter Measure the current value of the CONTROLLER's power cord by the clamp meter. Fasten the holder so that the increase in the no-load current value (during rotation at the maximum rotation speed) with the motor spindle fastened is 50mA (for type 200V / 230V) or less, compared to the no-load current value (during rotation at the maximum rotation speed) without fastening the motor spindle. Do not over-tighten the Fastening Bolt. It may damage motor spindle's precision and shorten the life of the bearings.
- The final responsibility for ensuring holder's safety for use in a given application is left to the designer of the equipment in which NAKANISHI's motor spindle is installed. NAKANISHI offers motor spindles with a wide variety of capabilities and specifications. Please carefully check the motor spindle's specifications against the requirements of your equipment and verify suitability and safety of the Holder prior to initial use.

8. BREAK-IN PROCEDURE

During transportation, storage or installation the grease inside the bearings will settle. If the spindle is suddenly run at high-speed excessive heat will cause bearing damage. After installation, repair, initial operation, or long periods of non operation please follow the break-in procedure detailed in Table 1.

Table 1.

Steps	1	2	3	4
BMS - 4040 BMS - 4040RA Rotation Speed (min ⁻¹)	10,000	20,000	30,000	40,000
BMS - 4040 BMS - 4040RA Rotation Speed (min ⁻¹)	5,000	10,000	15,000	20,000
Rotation Time (min)	15	10	10	15
Items to Check	No Abnormal Noises	The motor spindle housing temperature during the break-in process should not exceed 25 degrees C (45 degrees F) above ambient temperature. Should the motor spindle exceed this limit, rest the motor spindle for at least 20 minutes and re-start the break in procedure from the beginning. If the housing temperature rises again and exceeds 25 degrees C (45 degrees F) above ambient temperature, check the motor spindle for proper installation.		The motor spindle housing temperature during the break-in process should not exceed 25 degrees C (45 degrees F) above ambient temperature.

9. CAUTIONS WHEN USING GRINDSTONES AND TOOLS

CAUTION

The maximum surface speed or rpm is always specified for a grindstone. Do not exceed the maximum speed with reference to the calculating chart below. Always follow the grindstone manufacturer's recommendations.

$$\text{Surface Speed (m / s)} = \frac{3.14 \times \text{Diameter (mm)} \times \text{rotation speed (min}^{-1}\text{)}}{1,000 \times 60}$$

- ① The proper surface speed for general grindstones is 10 - 30m / s.
- ② Do not exceed 13mm of overhang for mounted grindstones as shown in Fig. 22. If the overhang must exceed 13mm, reduce the motor speed in accordance with table 2.
- ③ Dress the grindstone prior to use.
- ④ Do not use cutting tools with bent or broken shanks, cracks or excessive run-out.
- ⑤ For grinding, the maximum depth of cut should not exceed 0.01mm radially or axially. Reciprocate the tool several times after each pass to eliminate tool pressure.
- ⑥ Always operate tools within the allowable recommended speed of the tools. Use of a tool outside of the allowable speed of the tools could cause damage to the spindle and injury to the operator.
- ⑦ Keep the tool shank and collet clean. If contaminants are left in the collet or collet nut, excessive run-out will cause damage to the tool and or spindle.
- ⑧ Do not strike or disassemble the spindle.
- ⑨ Please set the tools to minimize the overhang amount. 13mm is the maximum amount of overhang to maintain high accuracy and safety.

Table 2. Overhang and Speed

Overhang (mm)	Max. Speed (min ⁻¹)
20	N x 0.5
25	N x 0.3
50	N x 0.1

N=Max. Operating Speed with 13mm overhang.

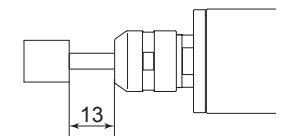

Fig. 22

10. TROUBLESHOOTING

If a problem or concern occurs, please check the following prior to consulting your dealer.

Trouble	Cause	Inspection / Corrective Action
Spindle does not rotate or rotate smoothly.	The spindles bearings have been damaged.	Replace the ball bearings. (Return to NAKANISHI dealer service.)
	The motor has been damaged.	Replace the motor. (Return to NAKANISHI dealer service.)
Overheating during rotation.	Cutting debris has contaminated the ball bearing, and the ball bearings are damaged.	Replace the ball bearings. (Return to NAKANISHI dealer service.)
	Low air pressure.	Check air hose connection and air pressure.
Abnormal vibration or noise during rotation.	The tool shank is bent.	Replace the tool.
	Cutting debris has contaminated the ball bearing.	Replace the ball bearings. (Return to NAKANISHI dealer service.)
	The spindles bearings have been damaged.	
Tool slippage.	Collet or collet nut are not correctly installed.	Check and clean the collet and collet nut. And, tighten the collet accurately again.
	The collet and the collet nut are worn.	Replace the collet and the collet nut.
High run-out.	The tool is bent.	Change the cutting tool.
	Collet nut is not correctly installed.	Secure the collet and the collet nut correctly.
	The collet and the collet nut are worn.	Replace the collet and the collet nut.
	Inside of the spindle is worn.	Replace the spindle shaft. (Return to NAKANISHI dealer service.)
	Contaminants inside the collet and the collet nut or the spindle.	Clean the collet, collet nut and the inside of the spindle.
	The ball bearings are worn.	Replace the ball bearings. (Return to NAKANISHI dealer service.)

Refer to the E4000 CONTROLLER Operation Manual.

11. DISPOSAL OF THIS PRODUCTS

When disposal of BMS - 4020, BMS - 4020RA, BMS - 4040 and BMS - 4040RA are necessary, follow the instructions from your local government agency for proper disposal of electrical components.

NAKANISHI INC. ■
700 Shimohinata, Kanuma
Tochigi 322-8666
Japan
www.nakanishi-inc.com

NSK America Corp.
1800 Global Parkway
Hoffman Estates
IL 60192, USA
www.nskamericacorp.com

NSK Europe GmbH ■
Elly-Beinhorn-Strasse 8
65760 Eschborn
Germany

NSK United Kingdom Ltd.
UK Authorised Representative
Office 4, Gateway 1000
Arlington Business Park, Whittle Way
Stevenage, SG1 2FP, UK