

# Motor Spindle

# EMSF-3060K

## OPERATION MANUAL

Thank you for purchasing Motor Spindle " EMSF - 3060K ". This Motor Spindle is designed for grinding, small diameter drilling and milling, etc. The E3000 CONTROLLER and Air Line Kit are required to drive this Motor Spindle. Read this and all the associated component Operation Manuals carefully before use. Always keep this Operation Manual in a place where a user can referred to for reference at any time.

### 1. CAUTIONS FOR HANDLING AND OPERATION

- Read these warnings and cautions carefully and only use in the manner intended.
- These warnings and cautions are intended to avoid potential hazards that could result in personal injury to the operator or damage to the device. These are classified as follows in accordance with the seriousness of the risk.

Class	Degree of Risk
<b>⚠ WARNING</b>	<b>A safety hazard could result in bodily injury or damage to the device if the safety instructions are not properly followed.</b>
<b>⚠ CAUTION</b>	<b>A hazard that could result in light or moderate bodily injury or damage to the device if the safety instructions are not followed.</b>

#### **⚠ WARNING**

- ① This Motor Spindle is not a hand tool. It is designed to be used on CNC machines or special purpose machines.
- ② Do not touch the cutting tool while it is running. It is very dangerous.
- ③ Wear safety glasses, dust mask, and use a protective cover around the Spindle whenever the Spindle is rotating.
- ④ Never connect, disconnect or touch the Power Cord Plug or Motor Cord Plug with wet hands. This may cause an electric shock.
- ⑤ Never operate or handle the Motor Spindle until you have thoroughly read the Operation Manuals and safe operation has been confirmed.
  - 1) To prevent injuries / damages, check the Motor Spindle and cutting tool for proper installation, before operating the Motor Spindle.
  - 2) Before disconnecting the Motor Spindle, always turn the control power off and turn the compressed air supply to the CONTROLLER off. Then it is safe to remove the Motor Spindle.
- ⑥ When installing a Motor Spindle to a fixed base, make sure the fixed base is grounded in order to avoid the risk of an electric shock.
- ⑦ When installing a tool, tighten the collet chuck correctly and check again the collet chuck and chuck nut before use. Do not over-tighten the collet chuck. This may cause damage to the spindle.
- ⑧ Do not use bent, broken, chipped, out of round or sub-standard tools, as this may cause them to shatter or explode. Tools with fractures or a bent shank will cause injury to the operator. When using a new tool, rotate it in a low speed and increase speed gradually for safety.
- ⑨ Do not exceed the maximum recommended allowable tool speed. For your safety, use speeds below the maximum allowable speed.
- ⑩ Do not apply excessive force. This may cause tool slippage, tool damage, injury to the operator or loss of concentricity and precision.

## ⚠ CAUTION

- ① Do not drop or hit this Motor Spindle, as shock can damage to the internal components.
- ② Be sure to clean the collet chuck and chuck nut, the inside of the spindle before replacing the tool. If ground particles or metal chips stick to the inside of spindle or the collet chuck, damage to the collet chuck or spindle can occur due to the loss of precision.
- ③ When cleaning a Motor Spindle, stop the Motor Spindle and remove debris with a soft brush or a cloth. Do not blow air into the dust proof cover area (refer to section " 6 - 2 Outside View ") with compressed air as foreign particles or cutting debris may get into the ball bearing.
- ④ Always clean the tool shank before installing the tool in the Motor Spindle.
- ⑤ When sizing the correct collet chuck size to the tool shank diameter, a tolerance of  $+0 \sim - 0.01\text{mm}$  is strongly recommended. A tool shank within the  $+0 \sim - 0.1\text{mm}$  range is mountable, however, this may cause poor concentricity and or insufficient tool shank gripping force.
- ⑥ Select suitable products or tools for all applications. Do not exceed the capabilities of the Motor Spindle or tools.
- ⑦ Do not stop the supply cooling air for motor during operation of the machine. Removing the air pressure from the Motor Spindle causes a loss of purging, allowing the Motor Spindle to ingest coolant. This will cause damage to the Motor Spindle.
- ⑧ Carefully direct coolant spray to the tool. Do not spray directly on the Motor Spindle body. If large amount spray directly on the Motor Spindle, it may cause excess load of the motor rotation with loss of durability to the Motor Spindle.
- ⑨ Stop working immediately when abnormal rotation or unusual vibration are observed. Immediately, please check the content of section " 13. TROUBLESHOOTING ".
- ⑩ Always check if the tool, collet chuck, chuck nut, connection hose and supply air hose for damaged before and after operating.
- ⑪ If the collet chuck or chuck nut show signs of wear or damage, replace them before a malfunction or additional damage occurs.
- ⑫ After installation, repair, initial operation, or long periods of non operation, please refer to section " 11. BREAK-IN PROCEDURE " detailed in Table 2. When checking the spindle, no vibration or unusual sound should be observed during rotation.
- ⑬ Do not disassemble, modify or attempt to repair this Motor Spindle. Additional damage will occur to the internal components. Service must be performed by NSK NAKANISHI or an authorized service center.
- ⑭ When using this Motor Spindle for mass production, please consider the purchase of an additional Motor Spindle to be used as a back-up in case of emergency.
- ⑮ Securely connect the compressor supply connection hose and the air hose to the Air Line Kit and the Motor Spindle to avoid accidental disconnection during use.



## 2. BASIC PACKAGE

When opening the package, check if it includes all items listed in " Table.1 Packing List Contents ".

In the event of any shortage, please contact either NAKANISHI (see the " 4. CONTACT US " section) or your local dealer.

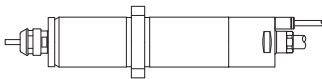
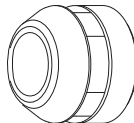
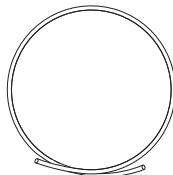
Table 1. Packing List Contents

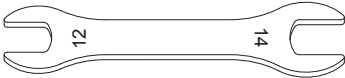
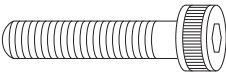
<p>EMSF - 3060K Motor Spindle • • 1pc.</p> 	<p>Chuck Nut (K - 265) • • 1pc.*</p> 	<p>Air Hose (0.3m) • • 1pc.*</p> 
--	--	--

<p>Wrench (12 × 14) • • 2pcs.</p> 	<p>Hexagon Socket Head Screw (M4 x 16) • • 4pcs.</p> 	<p>Inspection Card • • 1pc.</p> 
<p>Operation Manual • • 1set</p> 		

\* The chuck nut and Air Hose are attached to the Motor Spindle.

### 3. WARRANTY

We provide a limited warranty for our products. We will repair or replace the products if the cause of failure is due to the following manufactures defects. Please contact us or your local distributor for details.

- ① Defect in manufacturing.
- ② Any shortage of components in the package.
- ③ Where damaged components are found when initially opening the package.  
(This shall not apply if the damage was caused by the negligence of a customer.)

### 4. CONTACT US

For your safety and convenience when purchasing our products, we welcome your questions. If you have any questions about operation, maintenance and repair of the product, please contact us.

#### Contact Us

##### ● For U.S. Market

Company Name : **NSK America Corp.**  
Industrial Div.  
Business Hours : 8:00 to 17:00 (CST)  
(closed Saturday, Sunday and Public Holidays)  
U.S. Toll Free No. : +1 800 585 4675  
Telephone No. : +1 847 843 7664  
Fax No. : +1 847 843 7622  
Website : [www.nskamericacorp.com](http://www.nskamericacorp.com)

##### ● For Other Markets

Company Name : **NAKANISHI INC.**   
Business Hours : 8:00 to 17:00 (JST)  
(closed Saturday, Sunday and Public Holidays)  
Telephone No. : +81 289 64 3520  
e-mail : [webmaster-ie@nsk-nakanishi.co.jp](mailto:webmaster-ie@nsk-nakanishi.co.jp)

## 5. FEATURES

- ① The Motor Spindle housing is made from precision ground, hardened, stainless steel (SUS) with an outside diameter of  $\phi 30\text{mm}$ .
- ② Excellent durability and high reliability are obtained by using a high-speed brushless motor, which eliminates the need for brush replacement and frequent maintenance.
- ③ A quick disconnect cord is available for easy brushless motor removal.
- ④ Various sizes of collet chucks are available CHK 0.5mm - 6.35mm. Standard collet chuck is CHK 3.0mm or CHK 3.175mm. (For U.S. market CHK 3.175mm.)

## 6. SPECIFICATIONS AND DIMENSIONS

### 6 - 1 Specifications

Model	EMSF - 3060K
Maximum Motor Rotation Speed	60,000min <sup>-1</sup> (rpm)
Spindle Accuracy	Less than 1 $\mu\text{m}$
Max. Output	350W
Weight	620g
IP Code	IP57 (When air is supplied.)

<Options>

Motor Cord *Note 1	3m, 4(3.7)m, 6(5.7)m, 8(7.7)m (The Air Hose ( $\phi 4.0\text{mm}$ ) of the same length is attached.)
Collet Chuck (CHK - □□) *Note 2	$\phi 0.5\text{mm}$ - $\phi 6.0\text{mm}$ in 0.1mm increments and $\phi 2.35\text{mm}$ , $\phi 3.175\text{mm}$ , $\phi 6.35\text{mm}$

\*Note 1 : Motor Cord is sold separately.

Please select the suitable motor cord length for your application.

\*Note 2 : Collet Chuck is sold separately. Please select the suitable collet chuck size for your application.

### 6 - 2 Outside View

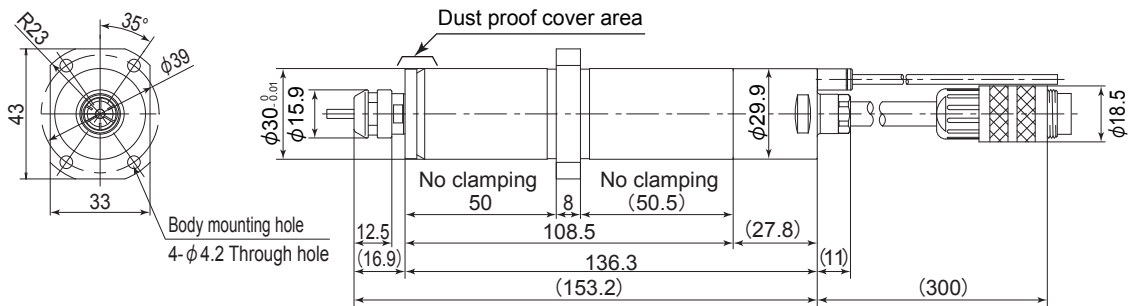

Fig. 1

### 6 - 3 Torque Characteristics

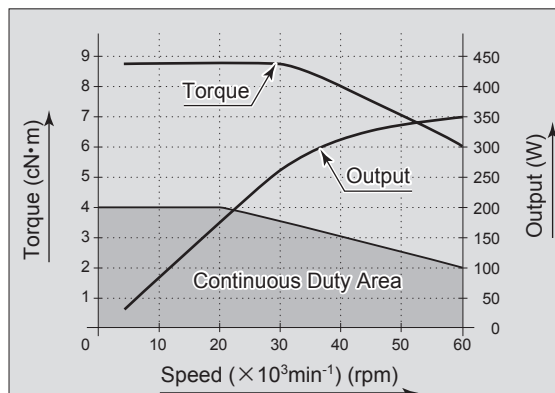

Fig. 2

## 7. CHANGING THE TOOL

### ⚠ CAUTION

Do not tighten the collet chuck without inserting a tool or dummy bur, as this will damage the collet chuck, spindle or chuck nut, causing difficulty removing the collet chuck.

### RECOMMENDATION

Please set the cutting tools to minimize the overhang amount. 13mm is the maximum amount of overhang to maintain high accuracy and safety.

- ① Set the provided 12mm wrench on the spindle.
- ② Place the provided 14mm wrench on the chuck nut and turn it counterclockwise to loosen the collet chuck and remove the tool. (The first turn will loosen the chuck nut, but the tool will not release and turning will become stiff. Keep turning through the stiffness and the collet chuck will open.)
- ③ Clean the collet chuck and chuck nut, then insert the new tool and tighten the collet chuck by turning clockwise. Do not overtighten.

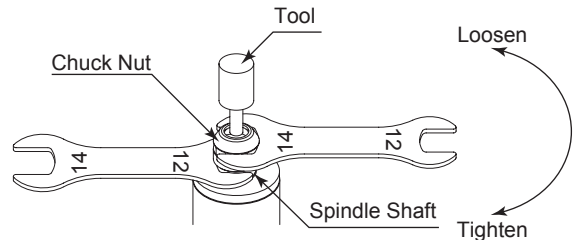

Fig. 3

## 8. REPLACING THE COLLET CHUCK

### ⚠ CAUTION

When installing the collet chuck into the chuck nut, be sure to fully engage the latch inside the chuck nut to the groove on the collet chucks outer diameter area. In addition, remember that if the collet chuck is attached without being engaged with the latch of the chuck nut, the collet chuck cannot be removed and this may cause damage to the collet chuck or the spindle.

- ① Remove the tool according to the section "7. CHANGING THE TOOL" procedure above and remove chuck nut assembly (Fig. 4).
- ② The collet chuck and chuck nut are secured by a groove in the collet chuck and a flange in the chuck nut. To remove the collet chuck hold the chuck nut in one hand and push diagonally down on the collet chuck. The collet chuck should be released (Fig. 5).
- ③ To install the collet chuck, hold the collet chuck at a slight angle, and insert it into the chuck nut (Fig. 6).

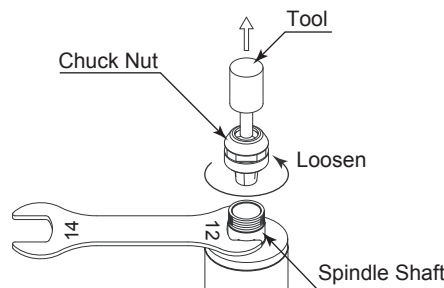

Fig. 4

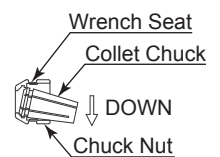

Fig. 5

Press the collet chuck in the chuck nut by positioning the collet chuck in the chuck nut and pressing down on flat surface (Fig. 5). Be sure to fully engage the latch inside the chuck nut into the groove on the collet chucks outer circumference area (Fig. 7).

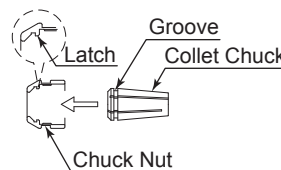

Fig. 6

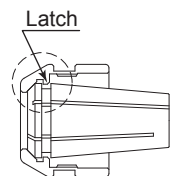

Fig. 7

## 9. CONNECTION OF MOTOR CORD

### ⚠ CAUTION

- Before connecting to the Motor Cord to the Motor and CONTROLLER, verify the Main Power Switch in the CONTROLLER is turned OFF. If the Main Power Switch on the CONTROLLER is ON while connecting the Motor Cord, damage to the CONTROLLER is possible.
- Install the protective cover (Protective Cover etc.) to prevent damage or contamination to the Motor Cord Plug when not in use.

- ① Remove the Protective Cover of the Motor Cord.

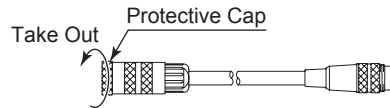

Fig. 8

- ② Carefully insert the Alignment Pin into the Alignment Hole and push straight into the Connector of the Motor Cord.

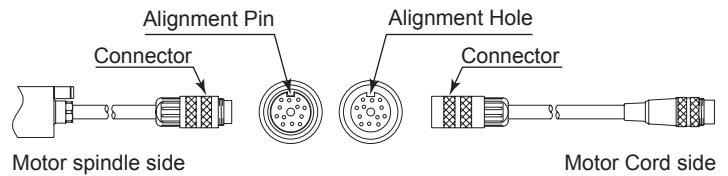

Fig. 9

- ③ Tighten the Coupling Nut with clockwise.

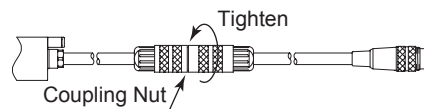

Fig. 10

- ④ Remove the protective air inlet Quick Disconnect Cover.

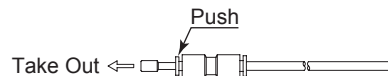

Fig. 11

- ⑤ Insert the provided air hose.

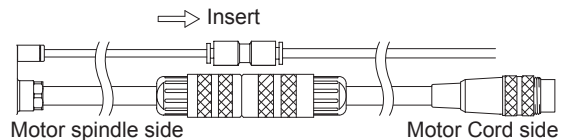

Fig. 12

## 10. INSTALLATION OF THE MOTOR SPINDLE

### ⚠ WARNING

When installing a Motor Spindle to a fixed base, make sure the fixed base is grounded in order to avoid the risk of an electric shock.

### ⚠ CAUTION

Do not allow set screws and the slit to come directly in contact with the Motor Spindle body as shown in Fig. 14, as this will result in damage to the Motor Spindle housing and internal components. Do not hit, drop or cause shock to the Motor Spindle when installing.

This flange designed to eliminate deformation / damage of the Motor Spindle when performing the installation. When install a Motor Spindle, refer to Fig. 13.

- ① Insert the Motor Spindle housing diameter section into the machines tool plate bore.
- ② Secure the Motor Spindle through the counter-sunk holes (4 locations) on the flange using Hexagon Socket Head Screw (M4 x 16) as shown in Fig. 13.

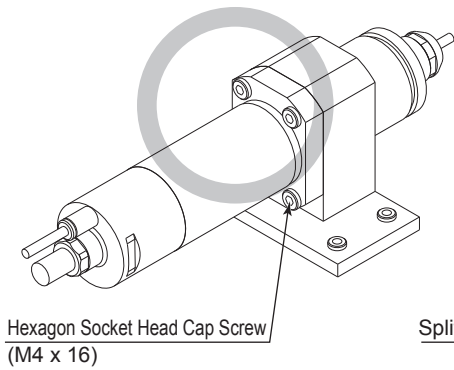

Fig. 13

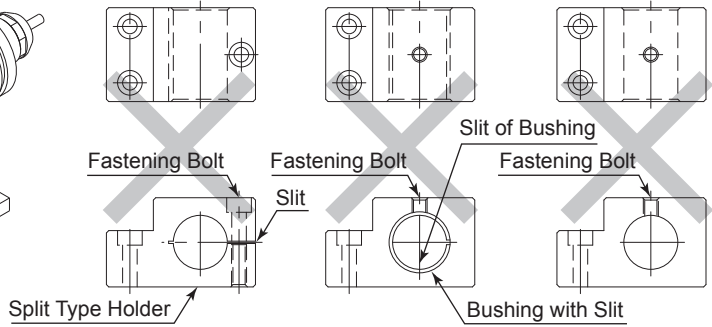

Fig. 14

## 11. BREAK-IN PROCEDURE

During transportation, storage or installation, the grease inside the bearings will settle. If the Spindle is suddenly run at high-speed, the grease will be ejected from the bearings, causing excessive heat that will cause bearing damage. After installation, repair, initial operation, or long periods of non operation, please follow the break-in procedure detailed in Table 2.

Table 2.

Steps	1	2	3	4	5
Rotation Speed (min <sup>-1</sup> ) (rpm)	15,000	30,000	40,000	50,000	60,000
Rotation Time (min)	15	10	10	10	15
Items to Check	No Abnormal Noises.	The motor spindle housing temperature during the break-in process should not exceed 20 degrees C (36 degrees F) above ambient temperature. Should the motor spindle exceed this limit, rest the motor spindle for at least 20 minutes and re-start the break in procedure from the beginning. If the housing temperature rises again and exceeds 20 degrees C (36 degrees F) above ambient temperature, check the motor spindle for proper installation.			The motor spindle housing temperature during the break-in process should not exceed 25 degrees C (36 degrees F) above ambient temperature.

## 12. CAUTIONS WHEN USING GRINDSTONES AND TOOLS

### ⚠ CAUTION

The maximum surface speed or rpm is always specified for a grindstone. Do not exceed the maximum speed with reference to the calculating chart below. Always follow the grindstone manufacturer's recommendations.

$$\text{Surface Speed (m/s)} = \frac{3.14 \times \text{Diameter (mm)} \times \text{rotation speed (min}^{-1}\text{) (rpm)}}{1,000 \times 60}$$

- ① The proper surface speed for general grindstones is 10-30m / s.
- ② Do not exceed 13mm of overhang for mounted grindstones as shown in Fig. 15. If the overhang must exceed 13mm, reduce the motor speed in accordance with Table 3.
- ③ Dress the grindstone prior to use.
- ④ Do not use cutting tools with bent or broken shanks, cracks or excessive run-out.
- ⑤ For grinding, the maximum depth of cut should not exceed 0.01mm radially or axially. Reciprocate the tool several times after each pass to eliminate tool pressure.
- ⑥ Always operate cutting tools within the allowable recommended speed of the cutting tools. Use of a cutting tool outside of the allowable speed of the cutting tools could cause damage to the Spindle and injury to the operator.

- ⑦ Keep the cutting tool shank and collet chuck clean. If contaminants are left in the collet chuck or chuck nut, excessive run-out will cause damage to the cutting tool and or Spindle.
- ⑧ Do not strike or disassemble the Spindle.
- ⑨ Please set the cutting tools to minimize the overhang amount. 13mm is the maximum amount of overhang to maintain high accuracy and safety.

Table 3. Overhang and Speed

Overhang (mm)	Max. Speed (min <sup>-1</sup> ) (rpm)
20	N x 0.5
25	N x 0.3
50	N x 0.1

※ N = Max. Operating Speed with 13mm overhang.

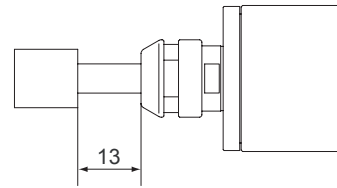

Fig. 15

## 13. TROUBLESHOOTING

If a problem or concern occur, please check the following items prior to consulting your dealer.

Trouble	Cause	Inspection / Corrective Action
Motor Spindle does not rotate or rotate smoothly.	The spindles ball bearings have been damaged.	Replace the ball bearings. (Return to NAKANISHI dealer service.)
	The motor has been damaged.	Replace the motor. (Return to NAKANISHI dealer service.)
Overheating during rotation.	Cutting debris has contaminated the ball bearings, and the ball bearings are damaged.	Replace the ball bearings. (Return to NAKANISHI dealer service.)
	Low air pressure.	Check air hose connection and air pressure.
Abnormal vibration or noise during rotation.	The tool shank is bent.	Replace the tool.
	Cutting debris has contaminated the ball bearing.	Replace the ball bearings. (Return to NAKANISHI dealer service.)
	The spindles ball bearings have been damaged.	
Tool slippage.	Collet chuck or chuck nut are not correctly installed.	Check and clean the collet chuck and chuck nut. Reinstall the collet chuck and chuck nut.
	The collet chuck and the chuck nut are worn.	Replace the collet chuck and chuck nut.
High run-out.	The tool is bent.	Change the tool.
	Chuck nut is not correctly installed.	Secure the collet chuck and the chuck nut correctly.
	The collet chuck and the chuck nut are worn.	Replace the collet chuck and the chuck nut.
	Inside of the spindle is worn.	Replace the spindle shaft. (Return to NAKANISHI dealer service.)
	Contaminants inside the collet chuck and the chuck nut or the spindle.	Clean the collet chuck, chuck nut and the inside of the taper and spindle.
	The spindle ball bearings has been damaged.	Replace the ball bearings. (Return to NAKANISHI dealer service.)

Refer to the E3000 CONTROLLER Operation Manual.

## 14. DISPOSAL OF THE MOTOR SPINDLE

When disposal of a Motor Spindle is necessary, follow the instructions from your local government agency for proper disposal of industrial components.

**NAKANISHI INC.**   
700 Shimohinata, Kanuma  
Tochigi 322-8666  
Japan  
www.nakanishi-inc.com

**NSK America Corp.**  
1800 Global Parkway  
Hoffman Estates  
IL 60192, USA  
www.nskamericacorp.com

**NSK Europe GmbH**   
Elly-Beinhorn-Strasse 8  
65760 Eschborn  
Germany

**NSK United Kingdom Ltd.**  
UK Authorised Representative  
Office 4, Gateway 1000  
Arlington Business Park, Whittle Way  
Stevenage, SG1 2FP, UK